

SELECTION

2024

WORKBOOK 2024

SÉLECTION DES MEILLEURS COMPOSANTS
ET ACCESSOIRES POUR LE CYCLISME

Selle Royal

fi'zi:k

crankbrothers

 Continental



WORKBOOK 2024

SELLE ROYAL	5
FIZIK	51
CRANKBROTHERS	151
CONTINENTAL	227
OVERVIEW	263

Selle Royal





SELLE ROYAL

Product categories



All Journeys Riding Everywhere

Il top di gamma di Selle Royal: questi prodotti sono perfetti per coloro che non vogliono scendere a compromessi, tanto negli spostamenti urbani quanto nelle avventure fuoriporta. La gamma All Journeys combina materiali di prima qualità e tecnologie innovative per garantire comfort e durata ottimali, senza rinunciare ad un design accattivante.

Ces produits Selle Royal, les meilleurs de leur catégorie, sont adaptables et parfaits pour ceux qui ne veulent pas lésiner sur l'excellence, que ce soit en ville ou à l'extérieur. Avec la gamme All Journeys, les matériaux de première qualité et les technologies innovantes permettent d'obtenir le meilleur en matière de confort, de design et de durabilité.



Adventure Time Exploring Outdoors

Le compagne di viaggio per le tue escursioni. Pedali per divertirti, per fare sport o per andare lontano? Questa gamma di selle è studiata per il tuo tempo libero in bicicletta. Tutti i modelli sono adatti a lunghe uscite e a diversi tipi di terreno, per esplorare la natura a modo tuo.

Une bouffée d'air frais pour toutes les excursions. Que vous roulez pour le plaisir, pour la forme ou pour partir en excursion loin de chez vous, cette gamme de selles donne le meilleur d'elle-même pour vous aider à profiter de votre temps libre à vélo. Tous ces modèles sont adaptés aux longues sorties et à différents types de terrains, pour que vous puissiez explorer la nature à votre guise.



Urban Life Moving in the City

Comfort ottimale per pedalare in città. Modelli studiati per accompagnarti nella vita di tutti i giorni, nei brevi tragitti o nei lunghi spostamenti in bici nella giungla urbana. Lasciati sorprendere dalla comodità, dallo stile e dall'affidabilità.

Le confort ultime pour le vélo en ville. Toute selle appartenant à cette gamme deviendra votre alliée de confiance au quotidien. Qu'il s'agisse de courtes balades ou de longs trajets, d'un style moderne ou d'une grande fiabilité, choisissez parmi de nombreux modèles en fonction de vos besoins en ville.

New packaging

Nuovo logo
Nouveau logo

La sella si presenta
La selle se présente elle-même

I vantaggi di prodotto sono evidenziati
in modo chiaro e sintetico

Les principaux avantages du produit
sont mis en évidence de manière claire
et concise

Le linee identificano il contesto di
utilizzo per aiutare il consumatore ad
orientarsi nella scelta della sella

La gamme de produits définit
l'utilisation de la selle afin de guider
le consommateur vers le bon choix
de selle



La riding position è più evidente
e comprensibile
La position de conduite est plus claire
et plus facile à comprendre

30 Day Comfort Guarantee
evidenziata sul fronte
La Garantie de confort de 30 jours
est mise en évidence sur l'avant

Nuovi colori per nuove linee
De nouvelles couleurs pour
de nouvelles gammes

Struttura apribile che permette di
includere più informazioni sul prodotto
L'emballage peut être ouvert pour
inclure plus d'informations sur
le produit

Spiegazione dei vantaggi specifici
della sella e delle caratteristiche di
prodotto che li determinano

Explication des principaux avantages
de la selle et des caractéristiques des
produits réutilisables



Nuovi testi in 6 lingue, linguaggio
più facile da comprendere e più
coinvolgente

Nouveaux textes en 6 langues, avec un
contenu plus facile et plus engageant

Spiegazione del concetto della riding
position e dell'approccio unisex

Explication du concept de position de
conduite et de l'approche unisex

Indicazioni di sostenibilità e
riciclabilità: packaging realizzato in
carta al 100% riciclata e riciclabile

Indications de durabilità et de
recyclage : emballage
fabriqué à partir de papier 100%
recyclé et recyclable

Indicazione del Made in Italy
Indication du Made in Italy

Riding positions

La posizione di guida è il fattore cruciale nella scelta della sella. A seconda dello stile di guida varia, infatti, il modo in cui le ossa del bacino poggiano sulla sella, influenzando quindi il livello di comfort generale. I prodotti di Selle Royal sono progettati ergonomicamente per accogliere le diverse larghezze di ossa ischiatiche e soddisfare le esigenze anatomiche di donne e uomini, garantendo la riduzione della pressione nelle zone più sensibili.

Scegli la tua corretta posizione di guida tra **45° (Athletic)**, **60° (Moderate)** e **90° (Relaxed)** e goditi le tue uscite in bici senza pensieri!

La position de conduite est un facteur crucial dans le choix de la selle optimale. En fonction de votre manière de rouler, la façon dont vos ischions reposent sur la selle varie considérablement et cela affecte par conséquent le niveau de confort. Les selles Selle Royal sont conçues de manière ergonomique pour s'adapter à toutes les largeurs d'ischions et satisfaire les besoins anatomiques des hommes et des femmes, en garantissant un soulagement de la pression dans les zones les plus sensibles.

Choisissez votre position de conduite entre **45° (Athletic)**, **60° (Moderate)** et **90° (Relaxed)** pour profiter de vos sorties sans douleur!

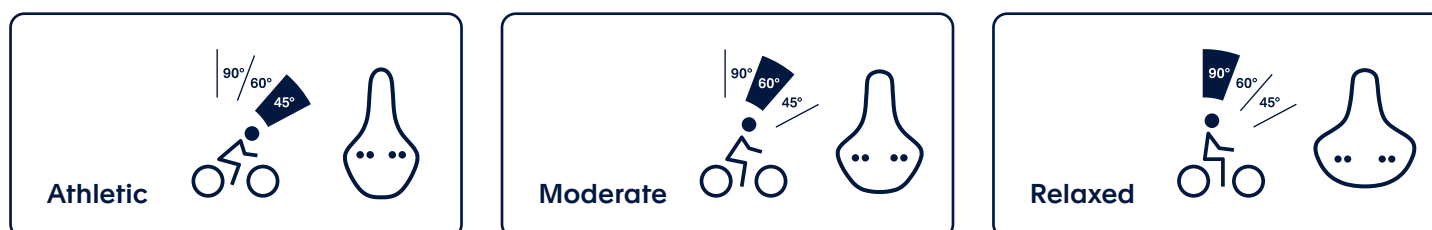

30 Day Comfort Guarantee

Selle Royal offre una Garanzia Comfort di 30 giorni su tutti i prodotti. Anche il nuovo packaging presenta uno specchietto sul fronte per informare i consumatori di questa opportunità: assicurati di assistere i tuoi clienti perché possano beneficiare di questo vantaggio!

Selle Royal offre une garantie de confort de 30 jours sur tous les produits. Le nouvel emballage affiche également clairement cette information sur le devant : assurez-vous d'informer correctement vos clients de cet avantage afin qu'ils puissent en profiter!



Product features

Royal Comfort



ROYALGEL™

Superiore a qualsiasi altra imbottitura grazie alla sua formulazione unica, Royalgel™ è studiato per garantire il massimo livello di comfort. Durevole e versatile, questa tecnologia assorbe la pressione e la distribuisce su tutta la superficie della sella, garantendo un supporto ottimale anche nelle pedalate più lunghe.

Supérieur à tout autre matériau de rembourrage, le Royalgel™ offre le plus haut niveau de confort grâce à sa formulation unique. Durable et polyvalente, cette technologie absorbe la pression et la répartit sur la surface de la selle pour offrir le meilleur soutien, même pour vos plus longues sorties.

Immediate Comfort



SLOW FIT FOAM

Ideale per brevi spostamenti, Slow Fit Foam è una tecnologia esclusiva di Selle Royal progettata per adattarsi alla forma del tuo corpo. La sua formulazione in memory foam a lento effetto di ritorno fornisce comfort ottimale e assicura una sensazione di morbidezza durante la pedalata.

Idéale pour les sorties courtes et faciles, la mousse Slow Fit Foam est une technologie exclusive de Selle Royal conçue pour épouser la forme de votre corps. Sa formulation en mousse à mémoire de forme, avec un effet de rebondissement lent, procure un confort immédiat et assure une sensation de douceur pendant la conduite.

Firm Comfort



FOAM MATRIX

Robusta, flessibile e adatta alle uscite di tutti i giorni: un'imbottitura in Foam Matrix è la scelta ideale se sei alla ricerca di un supporto stabile e solido per i tuoi viaggi brevi e meno impegnativi.

Robuste, mais flexible pour les trajets quotidiens. Si vous recherchez un soutien ferme et solide pendant vos trajets courts et faciles, une selle avec un rembourrage Foam Matrix est ce qu'il vous faut.

Extreme Durability



UNITECH

Dotate di un unico materiale per imbottitura e rivestimento, le selle con tecnologia Unitech sono progettate per durare a lungo. Grazie a impermeabilità e alta resistenza all'abrasione, non dovrai più preoccuparti delle intemperie e delle sfide della giungla urbana.

Avec un rembourrage et un revêtement en une seule pièce, les selles dotées de la technologie Unitech sont conçues pour durer, car elles sont très résistantes à l'abrasion et imperméables. Vous n'aurez donc pas à vous soucier d'exposer votre selle aux éléments ou aux dangers de la ville.

Waterproofness



ROYAL VACUUM

Rimani all'asciutto durante le tue pedalate! Progettata per resistere all'acqua, questa tecnologia brevettata da Selle Royal permette alla sella di essere sigillata al 100% e quindi impermeabile, anche quando esposta a forti intemperie.

Profitez d'un trajet au sec avec une selle résistante à l'eau. Cette technologie brevetée Selle Royal permet à la selle d'être 100% étanche et substantiellement imperméable, même lorsqu'elle est exposée à un temps lourd et humide.

Fresh Seat



COOL COVER

Una speciale composizione del rivestimento della sella riflette la luce del sole ed assicura una temperatura di 25°C più fresca rispetto ad una sella nera standard. Potrai così lasciare la tua bici al sole senza pensarci due volte.

La composition spéciale de cette housse reflète la lumière du soleil et maintient votre selle à 25°C de moins qu'une selle noire standard. Vous pouvez donc laisser votre vélo au soleil sans y penser.

Perineal Ventilation



VENTILATION CHANNEL

Grazie a questa funzione di ventilazione non dovrai più temere il caldo durante i tuoi giri in bici: uno speciale canale anatomico consente all'aria di fluire attraverso la sella ed assicura una sensazione di freschezza mentre pedali, oltre ad una pressione ridotta nella zona perineale.

Ne laissez pas la surchauffe gâcher votre sortie : le canal de ventilation permet à l'air de circuler à travers votre selle grâce à une découpe anatomique, garantissant une sensation de brise et de non transpiration lorsque vous roulez. Conçu pour des sorties à la fraîche et réduire la pression dans la zone périnéale.

Perineal Relief



ERGONOMIC HOLE

Un foro centrale ergonomico progettato per alleviare la pressione nella zona perineale. Ideale anche per i ciclisti più sensibili: niente più fastidio durante le tue pedalate!

Une découpe centrale ergonomique conçue pour soulager la pression dans la zone périnéale, ce qui la rend idéale pour les cyclistes les plus sensibles. Pas de douleur, juste un avantage sur vos sorties!



ERGONOMIC CHANNEL

Un canale progettato per seguire ergonomicamente la forma del corpo, offrendo sollievo dalla pressione nella zona perineale e supporto nella zona ischiatica. Niente più dolore durante le tue uscite in bicicletta!

Cette échancrure est conçue pour épouser de manière ergonomique la forme du corps, en apportant un soulagement de la pression dans les zones de tissus sensibles et un soutien dans la zone ischiatique. Pas de douleur, juste un avantage sur vos sorties!

High Resistance



STRENGTEX

Un rivestimento ultra resistente, progettato per aumentare la durata della sella. Grazie alla sua struttura multistrato, la tua sella ricoperta in Strengetex resiste a forature, tagli, strappi, crepe o invecchiamento. Perfetta per la giungla urbana.

Il s'agit d'un matériau de revêtement ultra-résistant conçu pour accompagner ce que subit toute selle au cours de sa vie. Grâce à sa structure multicouche, votre revêtement Strengetex ne craint pas les perforations, les coupures, les déchirures, les fissures ou le vieillissement et rend donc votre selle parfaite pour la jungle urbaine.

Shock Absorption



FLEXITE SYSTEM

Uno scafo con esclusiva costruzione dentellata, per una flessibilità ottimizzata e assorbimento degli urti. L'ideale per pedalare in città e per gite nella natura, senza rinunciare al massimo del comfort.

La construction unique de la coque assure une flexibilité et une absorption des chocs maximales, garantissant des sorties en douceur en ville ou dans la nature.



THERMOPLASTIC DAMPER

Lavorando come un elastomero, questo ammortizzatore termoplastico posizionato nella parte posteriore della sella assorbe anche gli urti più forti ed assicura il massimo del comfort senza fare rumore.

Fonctionnant comme un élastomère, l'amortisseur thermoplastique placé à l'arrière de la selle adoucit les parcours cahoteux, en absorbant silencieusement les chocs les plus violents.



ELASTOMERS

Pedala prestando sempre attenzione agli ostacoli improvvisi. Ma se ne manchi uno, la tua sella con elastomeri assorbirà anche gli urti più forti, senza fare rumore.

Vous faites toujours attention aux obstacles inattendus, mais si vous en manquez un, votre selle avec élastomères absorbera les chocs les plus sévères sans faire de bruit.



CUPSPRINGS

Pedala prestando sempre attenzione agli ostacoli improvvisi. Ma se ne manchi uno, la tua sella con molle a tazza assorbirà anche gli urti più forti, senza fare rumore.

Vous faites toujours attention aux obstacles inattendus, mais si vous en manquez un, votre selle avec ressorts à coupelle absorbera les chocs les plus sévères sans faire de bruit.

Safe Sides



DOUBLE-COVER SIDE PROTECTION

Dimenticati dei lati della sella graffiati e appoggia la bici su qualsiasi superficie in totale libertà: il materiale a doppio strato applicato alle parti più esposte della sella aumenta la resistenza a urti e abrasioni.

Dites non aux flancs de selle éraflés et appuyez votre vélo contre n'importe quoi en toute liberté : le matériau double couche appliqué sur les flancs de la selle augmente la résistance aux impacts et aux abrasions.



SCUFF GUARDS

Dimenticati dei lati della sella graffiati e appoggia la bici su qualsiasi superficie in totale libertà: gli inserti extra protettivi applicati ai lati della sella aumentano la resistenza a urti e abrasioni.

Dites adieu aux flancs de selle éraflés et appuyez votre vélo sur n'importe quoi en toute liberté : les inserts de protection supplémentaires appliqués sur les flancs de la selle augmentent la résistance aux impacts et aux abrasions.

Safety at Night



REFLECTIVE FILM

Essere visibili alle altre macchine mentre si pedala è di fondamentale importanza, negli spostamenti urbani tanto quanto nelle avventure fuoripista. Questa pellicola riflettente aumenta la tua visibilità: l'ideale in condizioni di scarsa luminosità o se la tua luce posteriore dovesse scaricarsi.

Que vous rouliez en ville ou que vous exploriez la nature, il est primordial de toujours être vu par les voitures, les vélos et les autres véhicules. Si, ou plutôt quand, votre feu arrière vous fait défaut, ce film réfléchissant protégera vos arrières pour une dose supplémentaire de sécurité.

Spring Suspension



DOUBLE SPRINGS

Le doppie molle garantiscono il massimo assorbimento degli urti e conferiscono alla sella un fascino classico. Per un look impeccabile senza rinunciare all'ammortizzazione che ti serve in città.

Un look saisissant et une excellente suspension, tout en un : les ressorts standard ont évolué pour améliorer les performances de la suspension tout en conservant leur allure classique, afin que vous n'ayez pas à faire de compromis sur le style - ou l'amortissement.



SPRINGS

Garantendoti l'ammortizzazione che ti serve in città, le molle aggiungono un tocco classico alla tua bici.

Parfois, c'était mieux avant : les ressorts ajoutent une excellente suspension et une touche de classe à n'importe quel vélo.

Clip & Go



INTEGRATED CLIP SYSTEM

Studiato per i tuoi accessori Selle Royal, l'Integrated Clip System è posizionato nella parte posteriore della sella per facilitare l'aggancio di una borsetta o di altri accessori Selle Royal. Il tutto in un solo clip.

Un must pour vos accessoires Selle Royal : le système de clip intégré positionné à l'arrière de votre selle permet de fixer une sacoche de selle Selle Royal ou d'autres accessoires d'un simple clip.



MULTI-TOOL

Niente più imprevisti durante le tue uscite in bici. Questo multi-tool si fissa alla clip posteriore della tua sella Selle Royal con Integrated Clip System, in modo da essere sempre a portata di mano per regolazioni e riparazioni mentre sei in giro. Protetto da una custodia in gomma antiurto, questo multi-tool compatto è composto da 9 attrezzi di qualità, per il massimo dell'affidabilità e della durevolezza.

Soyez toujours prêt à faire face aux imprévus. Ce multi-outil se fixe à l'arrière de votre selle Selle Royal équipée du système de clip intégré (ICS) afin d'être toujours à portée de main pour des réglages et des réparations rapides en cours de route. Protégé par un boîtier en caoutchouc antiflanc, cet ensemble compact et sécurisé offre 9 outils pour des années d'utilisation fiable.

Support up to 150kg



HEAVY-DUTY SUPPORT

Testata fino a 150 kg, una sella affidabile e durevole che non teme pesi elevati.

Testée jusqu'à 150 kg, une selle fiable et durable qui ne craint pas les poids lourds.

E-Bike Specific



E-FIT DESIGN

Un design innovativo dalla forma curva ti aiuta a trovare facilmente la posizione corretta sulla tua e-bike. Allo stesso tempo la sezione posteriore rialzata della sella previene lo scivolamento all'indietro e garantisce il massimo comfort per la tua schiena. Infine, i lati della sella sono flessibili in modo da migliorare la stabilità e facilitare la pedalata.

Un design innovant en forme de vague pour vous aider à trouver immédiatement la bonne position sur votre VAE. Sa section arrière surélevée vous empêchera de glisser vers l'arrière pour assurer un confort maximal à votre dos, tandis que les côtés de la selle, d'une flexibilité unique, ajoutent de la stabilité et facilitent le pédalage.

Easy Handling



E-GRIP

Una maniglia gommata "soft-touch" integrata nella parte posteriore della sella facilita la manovrabilità della tua e-bike.

Tenez bien en main votre vélo électrique grâce à cette fonctionnalité intelligente : une poignée intégrée et douce au toucher qui facilite les manœuvres.

Sustainable Choice



ECO APPROACH

Selle Royal rafforza il suo impegno per ridurre l'impatto ambientale dei suoi prodotti. La base di questa sella è realizzata al 100% con plastica riciclata, pur mantenendo lo stesso livello di flessibilità e comfort. Il rivestimento di origine biologica è composto per il 50% da materiali organici, garantendo la stessa elasticità, resistenza all'abrasione e livello di comfort pur utilizzando solo plastificanti naturali.

Selle Royal renforce son engagement à réduire l'impact environnemental de ses produits. La base de cette selle est fabriquée à partir de plastique 100% recyclé, tout en conservant le même niveau de flexibilité et de confort. Le revêtement BIO-sourcé est composé de 50% de matériaux organiques, garantissant le même niveau d'élasticité, de résistance à l'abrasion et de confort tout en utilisant uniquement des plastifiants naturels.



All Journeys
Riding Everywhere





ON Athletic
Unisex

-  E-Fit Design
-  Royalgel™
-  E-Grip
-  Royal Vacuum
-  Integrated Clip System



ON Moderate
Unisex

-  E-Fit Design
-  Royalgel™
-  E-Grip
-  Royal Vacuum
-  Integrated Clip System



ON Relaxed
Unisex

-  E-Fit Design
-  Royalgel™
-  E-Grip
-  Royal Vacuum
-  Integrated Clip System



ARTICLE	EAN	NAME	RIDING POSITION	GENDER	SIZES	PRICE (€)
94C7UROA05X37	8021890570239	On	Athletic	Unisex	L 281mm / W 157mm / W 465g	89,90
94C8DROA05X37	8021890570260	On	Moderate	Unisex	L 268mm / W 190mm/ W 531g	89,90
94C9UROA05X37	8021890570291	On	Relaxed	Unisex	L 269mm / W 224mm / W 642g	89,90

NEW



ON OPEN Athletic
Unisex

-  Royal Vacuum
-  E-Fit Design
-  E-Grip
-  Royalgel™
-  Ergonomic Hole
-  Integrated Clip System



NEW



ON OPEN Moderate
Unisex

-  Royal Vacuum
-  E-Fit Design
-  E-Grip
-  Royalgel™
-  Ergonomic Hole
-  Integrated Clip System



NEW



ON OPEN Relaxed
Unisex

-  Royal Vacuum
-  E-Fit Design
-  E-Grip
-  Royalgel™
-  Ergonomic Hole
-  Integrated Clip System



ARTICLE	EAN	NEW	NAME	RIDING POSITION	GENDER	SIZES	PRICE (€)
94F6UROA05X37	8021890592477	NEW	On Open	Athletic	Unisex	L 281mm / W 158mm / W 443g	89,90
94F7DROA05X37	8021890592491	NEW	On Open	Moderate	Unisex	L 269mm / W 190mm / W 499g	89,90
94F8UROA05X37	8021890592514	NEW	On Open	Relaxed	Unisex	L 270mm / W 224mm / W 629g	89,90

Royalgel™

Superiore a qualsiasi altra imbottitura grazie alla sua formulazione unica, Royalgel™ è studiato per garantire il massimo livello di comfort. Durevole e versatile, questa tecnologia assorbe la pressione e la distribuisce su tutta la superficie della sella, garantendo un supporto ottimale anche nelle pedalate più lunghe.

Supérieur à tout autre matériau de rembourrage, le Royalgel™ offre le plus haut niveau de confort grâce à sa formulation unique. Durable et polyvalente, cette technologie absorbe la pression et la répartit sur la surface de la selle pour offrir le meilleur soutien, même pour vos plus longues sorties.



Royal Vacuum

Rimani all'asciutto durante le tue pedalate! Progettata per resistere all'acqua, questa tecnologia brevettata da Selle Royal permette alla sella di essere sigillata al 100% e quindi impermeabile, anche quando esposta a forti intemperie.

Profitez d'un trajet au sec avec une selle résistante à l'eau. Cette technologie brevetée Selle Royal permet à la selle d'être 100% étanche et substantiellement imperméable, même lorsqu'elle est exposée à un temps lourd et humide.

e-Fit Design

Un design innovativo dalla forma curva ti aiuta a trovare facilmente la posizione corretta sulla tua e-bike. Allo stesso tempo la sezione posteriore rialzata della sella previene lo scivolamento all'indietro e garantisce il massimo comfort per la tua schiena. Infine, i lati della sella sono flessibili in modo da migliorare la stabilità e facilitare la pedalata.

Un design innovant en forme de vague pour vous aider à trouver immédiatement la bonne position sur votre VAE. Sa section arrière surélevée vous empêchera de glisser vers l'arrière pour assurer un confort maximal à votre dos, tandis que les côtés de la selle, d'une flexibilité unique, ajoutent de la stabilité et facilitent le pédalage.



Integrated Clip System

Studiato per i tuoi accessori Selle Royal, l'Integrated Clip System è posizionato nella parte posteriore della sella per facilitare l'aggancio di una borsetta o di altri accessori Selle Royal. Il tutto in un solo clip.

Un must pour vos accessoires Selle Royal : le système de clip intégré positionné à l'arrière de votre selle permet de fixer une sacoche de selle Selle Royal ou d'autres accessoires d'un simple clip.

Ergonomic Hole

Un foro centrale ergonomico progettato per alleviare la pressione nella zona perineale. Ideale anche per i ciclisti più sensibili: niente più fastidio durante le tue pedalate!

Une découpe centrale ergonomique conçue pour soulager la pression dans la zone périnéale, ce qui la rend idéale pour les cyclistes les plus sensibles. Pas de douleur, juste un avantage sur vos sorties !



e-Grip

Una maniglia gommata "soft-touch" integrata nella parte posteriore della sella facilita la manovrabilità della tua e-bike.

Tenez bien en main votre vélo électrique grâce à cette fonctionnalité intelligente : une poignée intégrée et douce au toucher qui facilite les manœuvres.



RESPIRO Athletic
Unisex

- Royalgel™
- Ventilation Channel
- Cool Cover
- Scuff Guards
- Royal Vacuum
- Integrated Clip System



RESPIRO Moderate
Unisex

- Royalgel™
- Ventilation Channel
- Cool Cover
- Scuff Guards
- Elastomers
- Royal Vacuum
- Integrated Clip System



RESPIRO Relaxed
Unisex

- Royalgel™
- Ventilation Channel
- Cool Cover
- Scuff Guards
- Elastomers
- Royal Vacuum
- Integrated Clip System



ARTICLE	EAN	NAME	RIDING POSITION	GENDER	SIZES	PRICE (€)
5130HRTB691L4	8021890575098	Respiro	Athletic	Unisex	L 279mm / W 159mm / W 429g	79,90
5131HETB291L4	8021890578969	Respiro	Moderate	Unisex	L 277mm / W 182mm / W 535g	79,90
5132DETB291L4	8021890575104	Respiro	Relaxed	Unisex	L 256mm / W 227mm / W 771g	79,90



LOOKIN Athletic
Unisex

-  Royalgel™
-  Cool Cover
-  Scuff Guards
-  Royal Vacuum
-  Integrated Clip System



LOOKIN Moderate
Unisex

-  Royalgel™
-  Cool Cover
-  Scuff Guards
-  Elastomers
-  Royal Vacuum
-  Integrated Clip System



LOOKIN Relaxed
Unisex

-  Royalgel™
-  Cool Cover
-  Scuff Guards
-  Elastomers
-  Royal Vacuum
-  Integrated Clip System



ARTICLE	EAN	NAME	RIDING POSITION	GENDER	SIZES	PRICE (€)
5234HR3A39188	8021890575135	Lookin	Athletic	Unisex	L 279mm / W 160mm / W 440g	69,90
5235DE3A39188	8021890578990	Lookin	Moderate	Unisex	L 269mm / W 198mm / W 620g	69,90
5236DE3A59188	8021890575142	Lookin	Relaxed	Unisex	L 260mm / W 228mm / W 830g	69,90



LOOKIN Evo Athletic
Unisex



Eco Approach



Royalgel™



Flexyte System



Royal Vacuum



Integrated Clip System



LOOKIN Evo Moderate
Unisex



Eco Approach



Royalgel™



Flexyte System



Royal Vacuum



Integrated Clip System



LOOKIN Evo Relaxed
Unisex



Eco Approach



Royalgel™



Flexyte System



Cupsprings



Royal Vacuum



Integrated Clip System



ARTICLE	EAN	NAME	RIDING POSITION	GENDER	SIZES	PRICE (€)
52E2UROA0B004	8021890579027	Lookin Evo	Athletic	Unisex	L 261mm / W 158mm / W 448g	74,90
52E3HROA0B004	8021890579034	Lookin Evo	Moderate	Unisex	L 271mm / W 186mm / W 500g	74,90
52E4UEOA0B004	8021890579041	Lookin Evo	Relaxed	Unisex	L 248mm / W 223mm / W 682g	74,90

WE STARTED FROM THE

BOTTOM



Lookin Evo

100% recycled plastic base + 50% BIO-sourced cover =
-24% CO₂ emissions



Adventure Time

Exploring Outdoors





VAIA Athletic
Unisex

-  Royalgel™
-  Ergonomic Hole
-  Royal Vacuum
-  Integrated Clip System
-  Multi-Tool



VAIA Moderate
Unisex

-  Royalgel™
-  Ergonomic Hole
-  Royal Vacuum
-  Integrated Clip System
-  Multi-Tool



VAIA Relaxed
Unisex

-  Royalgel™
-  Ergonomic Hole
-  Thermoplastic Damper
-  Royal Vacuum
-  Integrated Clip System



ARTICLE	EAN	NAME	RIDING POSITION	GENDER	SIZES	PRICE (€)
84E5UROA05X38	8021890593504	Vaia	Athletic	Unisex	L 271mm / W 151mm / W 382g	69,90
84E6HROA05X38	8021890593511	Vaia	Moderate	Unisex	L 270mm / W 167mm / W 406g	69,90
84E7UEOA05X38	8021890593528	Vaia	Relaxed	Unisex	L 250mm / W 213mm / W 580g	69,90



Multi-Tool Integrated

Questo multitool si aggancia al retro di ogni sella Selle Royal grazie all'Integrated Clip System (ICS). Incluso nelle selle Athletic e Moderate Vaia, è l'ideale per essere sempre a portata di mano per regolazioni e facili riparazioni in viaggio. Protetto da un custodia in gomma antiurto, questo multitool compatto e sicuro include 9 attrezzi affidabili e durevoli nel tempo.

Ce multi-outil se fixe à l'arrière de n'importe quelle selle Selle Royal grâce au système de clip intégré (ICS). Il est déjà inclus dans les selles Athletic et Moderate Vaia afin d'être toujours à portée de main pour des réglages et des réparations rapides sur la route. Protégé par un boîtier en caoutchouc antichoc, cet ensemble compact et sûr offre 9 outils pour des années d'utilisation fiable.

Water Resistant

Royal Vacuum Light è una tecnologia Selle Royal brevettata che consente al rivestimento di essere al 100% sigillato e per questo resistente all'acqua. Inoltre, questo rende la sella il 20% più leggera!

Royal Vacuum Light est une technologie brevetée Selle Royal qui permet à la selle d'être 100% étanche et donc résistante à l'eau. De plus, cela la rend 20% plus légère!



Ergonomic Hole

Un foro centrale ergonomico progettato per alleviare la pressione nella zona perineale, ideale per chi è più sensibile. Questa sella con foro ergonomico segue la forma del corpo, offrendo massimo sollievo dalla pressione nella zona perineale e sostegno nella zona ischiatica.

Une découpe centrale ergonomique conçue pour soulager la pression dans la zone périnéale, ce qui la rend idéale pour les cyclistes les plus sensibles. Cette selle à découpe ergonomique épouse la forme du corps, offrant un soulagement supérieur de la pression dans la zone périnéale et un soutien dans la zone ischiatique.

Royalgel™

Grazie alla sua speciale struttura tridimensionale, Royalgel™ garantisce il più alto livello di comfort, riducendo i picchi di pressione del 40% rispetto alle normali imbottiture.

Grâce à sa structure tridimensionnelle unique en gel, Royalgel™ garantit le plus haut niveau de confort, réduisant ainsi les pics de pression de 40% par rapport aux matériaux de rembourrage habituels.

Thermoplastic Damper

(solo in posizione di marcia a 90°)
(Uniquement en position de pédalage 90°)

Lavorando come un elastomero, questo ammortizzatore indeformabile fisso posto nella parte posteriore assorbe anche gli shock più severi e inaspettati, per garantire una performance sicura, silenziosa e confortevole.

Fonctionnant comme un élastomère, ce mono amortisseur absolument indéformable, positionné à l'arrière de la selle, absorbe même les chocs les plus violents et inattendus procurant sécurité, silence et confort.



Integrated Clip System

Sistema a clip brevettato posto nel retro della sella, per un'installazione facile delle borsette sottosella Selle Royal o di altri accessori.

Un système de clip breveté positionné à l'arrière de la selle permet de fixer facilement une sacoche de selle Selle Royal ou tout autre accessoire.



 selle royal

Selle Royal



EXPLORA Athletic
Unisex



Royalgel™



Ergonomic Channel



Royal Vacuum



Integrated Clip System



EXPLORA Moderate
Unisex



Royalgel™



Ergonomic Channel



Royal Vacuum



Integrated Clip System



EXPLORA Relaxed
Unisex



Royalgel™



Ergonomic Channel



Thermoplastic Damper



Royal Vacuum



Integrated Clip System



ARTICLE	EAN	NAME	RIDING POSITION	GENDER	SIZES	PRICE (€)
54D1UR0A05X38	8021890569721	Explora	Athletic	Unisex	L 274mm / W 152mm / W 379g	69,90
54D2HROA05X38	8021890569745	Explora	Moderate	Unisex	L 273mm / W 171mm / W 415g	69,90
54D3UE0A05X38	8021890569769	Explora	Relaxed	Unisex	L 253mm / W 218mm / W 598g	69,90









Urban Life Moving in the City





ELLIPSE Athletic
Unisex

-  Royalgel™
-  Ergonomic Hole
-  Double-Cover Side Protection
-  Royal Vacuum
-  Integrated Clip System



ELLIPSE Moderate
Unisex

-  Royalgel™
-  Ergonomic Hole
-  Double-Cover Side Protection
-  Elastomers
-  Royal Vacuum
-  Integrated Clip System



ELLIPSE Relaxed
Unisex

-  Royalgel™
-  Ergonomic Hole
-  Double-Cover Side Protection
-  Elastomers
-  Royal Vacuum
-  Integrated Clip System



ARTICLE	EAN	NAME	RIDING POSITION	GENDER	SIZES	PRICE (€)
81B5UR0A09320	8021890593474	Ellipse	Athletic	Unisex	L 265mm / W 163mm / W 406g	54,90
81B6HE0A09321	8021890593481	Ellipse	Moderate	Unisex	L 276mm / W 180mm / W 474g	54,90
81B7UE0A09321	8021890593498	Ellipse	Relaxed	Unisex	L 250mm / W 223mm / W 638g	54,90



FREEWAY FIT Athletic
Unisex



Slow Fit
Foam



Royal
Vacuum



Integrated
Clip System



FREEWAY FIT Moderate
Unisex



Slow Fit
Foam



Scuff
Guards



Royal
Vacuum



Integrated
Clip System



FREEWAY FIT Relaxed
Unisex



Slow Fit
Foam



Scuff
Guards



Royal
Vacuum



Integrated
Clip System



ARTICLE	EAN	NAME	RIDING POSITION	GENDER	SIZES	PRICE (€)
8V99UROA38069	8021890575623	Freeway Fit	Athletic	Unisex	L 280mm / W 158mm / W 435g	44,90
8V97DROA38069	8021890578891	Freeway Fit	Moderate	Unisex	L 260mm / W 188mm / W 520g	44,90
8V98UROA38069	8021890575616	Freeway Fit	Relaxed	Unisex	L 257mm / W 210mm / W 550g	44,90



FLOAT Athletic Unisex

-  Slow Fit Foam
-  Ergonomic Hole
-  Royal Vacuum
-  Integrated Clip System



FLOAT Moderate Unisex

-  Slow Fit Foam
-  Ergonomic Hole
-  Elastomers
-  Royal Vacuum
-  Integrated Clip System



FLOAT Relaxed Unisex

-  Slow Fit Foam
-  Ergonomic Hole
-  Elastomers
-  Royal Vacuum
-  Integrated Clip System



ARTICLE	EAN	NAME	RIDING POSITION	GENDER	SIZES	PRICE (€)
8VC1UR0A38V14	8021890575593	Float	Athletic	Unisex	L 267mm / W 161mm / W 382g	44,90
8VC2DE0A38V14	8021890579003	Float	Moderate	Unisex	L 263mm / W 200mm / W 547g	44,90
8VC3UE0A38V14	8021890575609	Float	Relaxed	Unisex	L 251mm / W 228mm / W 628g	44,90



AVENUE Athletic
Unisex



AVENUE Moderate
Unisex



AVENUE Relaxed
Unisex



ARTICLE	EAN	NAME	RIDING POSITION	GENDER	SIZES	PRICE (€)
8468HGOA28096	8021890575661	Avenue	Athletic	Unisex	L 265mm / W 158mm / W 462g	39,90
8466DGOA28096	8021890578907	Avenue	Moderate	Unisex	L 258mm / W 183mm / W 664g	39,90
8493DGOA28096	8021890575678	Avenue	Relaxed	Unisex	L 267mm / W 218mm / W 730g	39,90



VIVO Athletic
Unisex



DRIFTER STRENGTEX
Relaxed / Unisex



DRIFTER PLUS Relaxed
Unisex



ARTICLE	EAN	NAME	RIDING POSITION	GENDER	SIZES	PRICE (€)
1217DRNA37823	6957312803093	Vivo	Athletic	Unisex	L 249mm / W 160mm / 375g	29,90
5111UDTC95301	8021890575371	Drifter Strengetex	Relaxed	Unisex	L 270mm / W 245mm / W 1160g	54,90
5111UDTD08129	8021890575388	Drifter Plus	Relaxed	Unisex	L 270mm / W 245mm / W 1173g	54,90



ONDINA Relaxed Unisex



Royalgel™



Springs



Royal Vacuum



Integrated Clip System



HOLLAND Relaxed Unisex



Royalgel™



Springs



Royal Vacuum



Integrated Clip System



WITCH Relaxed Unisex



Foam Matrix



Springs



Royal Vacuum



ARTICLE	EAN	NAME	RIDING POSITION	GENDER	SIZES	PRICE (€)
8171US0A98129	8021890575630	Ondina	Relaxed	Unisex	L 253mm / W 214mm / W 690g	34,90
82615G2A18132	8021890575654	Holland	Relaxed	Unisex	L 247mm / W 219mm / W 690g	29,90
8013USTA18096	8021890581570	Witch	Relaxed	Unisex	L 260mm / W 243mm / W 651g	19,90



Kids saddles



Kids Saddles

FROGGY

Consigliata per bici da bambini da 12"-14"-16"
Recommandées pour vélos enfants 12"-14"-16"



CANDY

Consigliata per bici da bambine da 16"-20"-24"
Recommandées pour vélos fillettes 16" - 20" - 24"

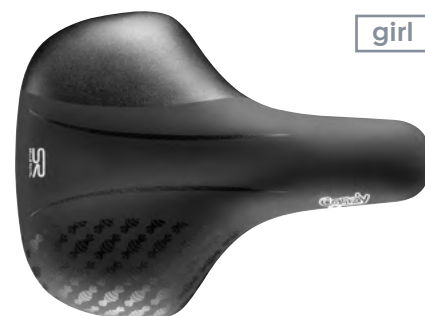

BEN

Consigliata per bici da bambini da 16"-20"-24"
Recommandées pour vélos enfants 16"-20"-24"

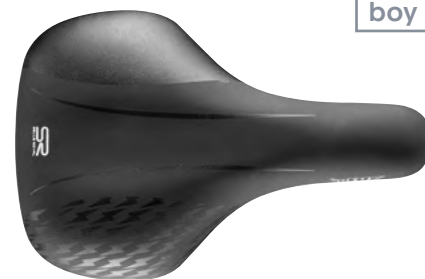

HELLO

Consigliata per bici junior da 24"
Recommandées pour vélo junior 24"

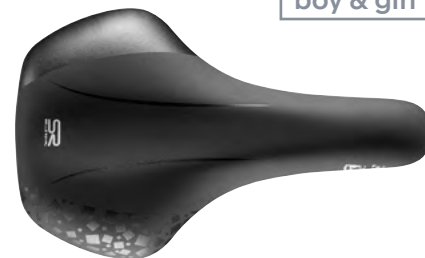

ARTICLE	EAN	NAME	RIDING POSITION	GENDER	SIZES	PRICE (€)
1702JCNA03807	6957312801310	Froggy	Kids 12"-16"	Boy & Girl	L 202mm / W 150mm / W 287g	19,90
1703DRNA03807	6957312801327	Candy	Kids 16"-24"	Girl	L 230mm / W 172mm / W 320g	19,90
1703HRNA03807	6957312801334	Ben	Kids 16"-24"	Boy	L 230mm / W 151mm / W 290g	19,90
1704JRNA03807	6957312801341	Hello	Junior 24"	Boy & Girl	L 250mm / W 151mm / W 325g	19,90

Saddle bags

Saddle Bag Medium - 1,2 l

Compatibile con Integrated Clip System, brugola inclusa, sistema di fissaggio esterno per luce.

Système de clip intégré compatible, clé allen incluse, clip d'éclairage externe.



Saddle Bag Large - 2,0 l

Compatibile con Integrated Clip System, brugola inclusa, impermeabile, sistema di fissaggio esterno per luce.

Compatible avec le système de clip intégré, clé allen incluse, étanche, clip d'éclairage externe.



Saddle Bag Extra Large - 7,0 l

Compatibile con Integrated Clip System, brugola inclusa, impermeabile, sistema di fissaggio esterno per luce, tracolla inclusa.

Système de clip intégré compatible, clé allen incluse, étanche, clip d'éclairage externe, bandoulière incluse.



ARTICLE	EAN	NAME	COVER	SIZES	PRICE (€)
BAGS300A00000	8021890494955	Saddle Bag Medium 1,2l	Polyester, PVC	L 210mm / W 95mm / H 115mm	19,90
BAGS400A00000	8021890494979	Saddle Bag Large 2,0l	Water resistant Polyester, PVC	L 330mm / W 190mm / H 95mm	24,90
BAGS500A00000	8021890574916	Saddle Bag Extra Large 7,0l	Water resistant Polyester, PVC	L 618mm / W 236mm / H 175mm	59,90

Seat Covers

Royalgel™ Seat Cover Small & Large - Unisex

Rientranza anatomica | Royalgel™ visibile
Empreinte anatomique | Royalgel™ visible



Slow Fit Foam Seat Cover Small & Large - Unisex

Rientranza anatomica | Slow Fit Foam
Empreinte anatomique | Slow Fit Foam



ARTICLE	EAN	NAME	COLOR	SIZES	PRICE (€)
SCVM300A05800	6957312803116	Royalgel™ Seat Cover Small	Black/Orange	L 270mm / W 190mm / W 244g	19,90
SCVL300A05800	6957312803147	Royalgel™ Seat Cover Large	Black/Orange	L 248mm / W 221mm / W 254g	19,90
SCMM100A75800	6957312803109	Slow Fit Foam Seat Cover Small	Black	L 273mm / W 185mm / W 160g	19,90
SCML100A75800	6957312803130	Slow Fit Foam Seat Cover Large	Black	L 251mm / W 220mm / W 168g	19,90

Accessories

**Packable Rain Cover
Dispenser**



**Clamp
Black / Silver**



ARTICLE	EAN	NAME	COLOR	SIZES/QUANTITY	PRICE (€)
SRSC000A00000	8021890574077	Packable rain cover dispenser	Black	L 107mm / W 120mm / H 258mm	11,90
V006000C00000	8021890472533	Clamp	Black	3 Components (single packaging)	3,00
V006000B90000	8021890472526	Clamp	Silver	3 Components (single packaging)	2,50
V006000C10000	8021890472540	Clamp	Silver	5 Components 38 D. (single packaging)	2,50
V006000B70000	8021890324665	Clamp	Black	3 Components + Locknut	2,00
V006000B60000	8021890324658	Clamp	Silver	3 Components + Locknut	2,00
V006000B80000	8021890324672	Clamp	Silver	5 Components 38 D.	2,00

Spare parts

Gli Original Spare Parts by Selle Royal sono selle adibite al ricambio e vengono fornite in masterbox dedicati. Sono provviste di un apposito bindello descrittivo invece dell'appendisella.

Les "Original Spare Parts by Selle Royal" sont des pièces de rechange d'origine fournies en cartons contenant un nombre de pièces déterminé. Elles sont pourvues d'une notice explicative au lieu d'un "hang tag".



Mach Box Athletic
Unisex / 28 pcs



Lancia Box Athletic
Unisex / 20 pcs



Avenue Box Athletic
Unisex / 24 pcs



Moody Box Moderate
Woman / 18 pcs



Rio Unitech Moderate
Unisex / 15 pcs



Holland Unitech Relaxed
Unisex / 10 pcs



ARTICLE	EAN	NAME	RIDING POSITION	GENDER	QUANTITY/BOX
SRTC000C70000	8021890459428	Mach Box	Athletic	Unisex	28 pcs
SRTC000C80000	8021890459435	Lancia Box	Athletic	Unisex	20 pcs
SRTC000C90000	8021890459442	Avenue Box	Athletic	Unisex	24 pcs
8072DROA18067	8021890443656	Moody Box	Moderate	Woman	18 pcs
302ODRMA12010	8021890498564	Rio Unitech	Moderate	Unisex	15 pcs
3061USOA12010	8021890485816	Holland Unitech	Relaxed	Unisex	10 pcs

SELLE ROYAL SCIENTIA FOR CYCLISTS

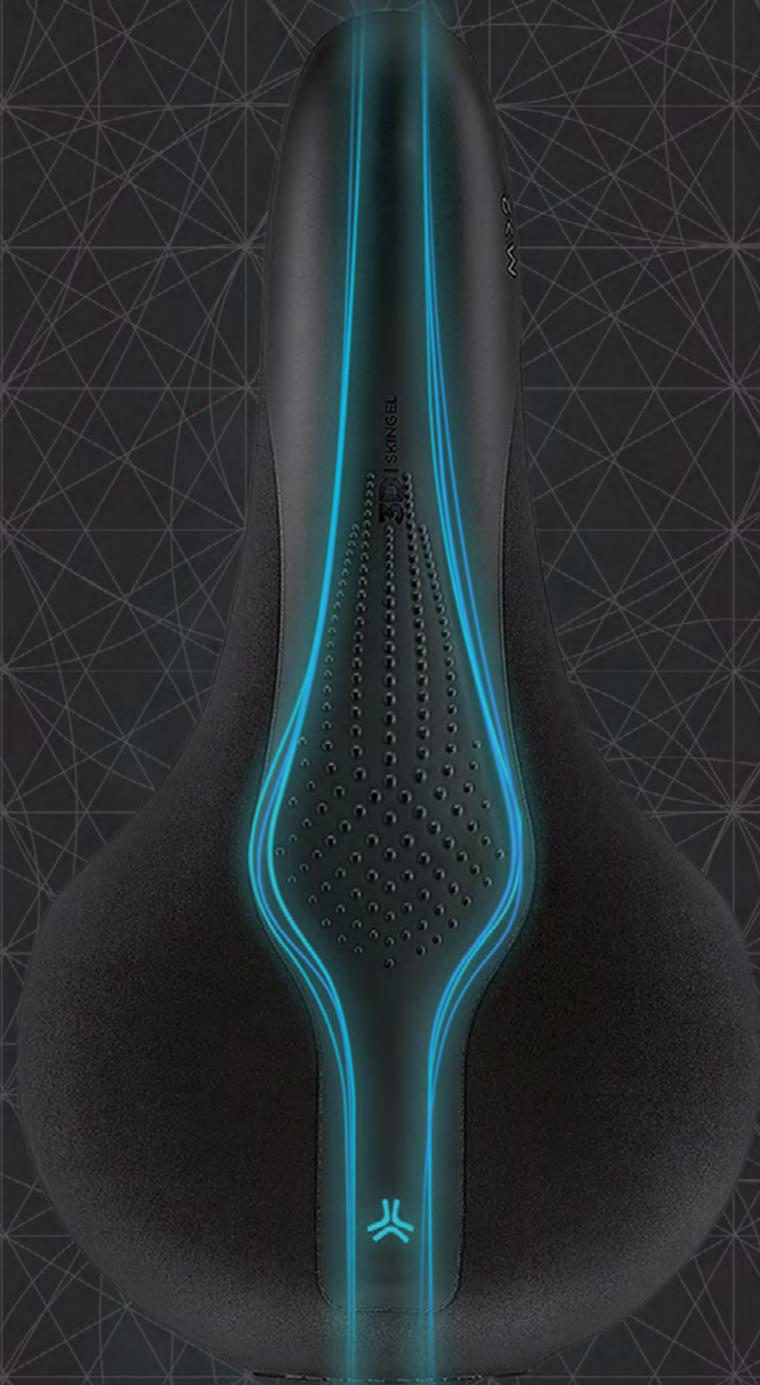

Scientifically developed in collaboration with



**Deutsche
Sporthochschule Köln**
German Sport University Cologne

Product range



ARTICLE	EAN	NAME	RIDING POSITION	ISCHIAL VARIATION	GENDER	SIZES	PRICE (€)
54AOSBOA09210	8021890427045	Scientia A1	Athletic	Small	Unisex	L 289mm / W 127mm / W 380g	89,90
54AOMBOA09210	8021890427038	Scientia A2	Athletic	Medium	Unisex	L 289mm / W 144mm / W 390g	89,90
54AOLBOA09210	8021890427021	Scientia A3	Athletic	Large	Unisex	L 289mm / W 159mm / W 415g	89,90
54MOSBOA09210	8021890427076	Scientia M1	Moderate	Small	Unisex	L 289mm / W 141mm / W 425g	89,90
54MOMBOA09210	8021890427069	Scientia M2	Moderate	Medium	Unisex	L 289mm / W 161mm / W 455g	89,90
54MOLBOA09210	8021890427052	Scientia M3	Moderate	Large	Unisex	L 289mm / W 178mm / W 465g	89,90
54ROSBOA09210	8021890427106	Scientia R1	Relaxed	Small	Unisex	L 289mm / W 169mm / W 479g	89,90
54ROMBOA09210	8021890427090	Scientia R2	Relaxed	Medium	Unisex	L 289mm / W 196mm / W 485g	89,90
54ROLBOA09210	8021890427083	Scientia R3	Relaxed	Large	Unisex	L 289mm / W 224mm / W 520g	89,90

Scientia features



Body contour | Contour du corps

Design dei bordi con raggio specifico per fornire un comfort ottimale per le diverse inclinazioni del ciclista. Maggiore è l'inclinazione della posizione di guida, minore è il raggio dei bordi.

Un profil conçu par rapport au rayon, optimisant le confort du cycliste en fonction de l'inclinaison de sa colonne vertébrale. Plus la position est inclinée, plus petit est le rayon.



Rear plateau | Plateau arrière

Una parte posteriore rialzata impedisce di arretrare con la posizione in sella e riduce la pressione al centro, in corrispondenza della zona perineale, garantendo così il comfort desiderato.

La partie arrière de la coque est surélevée afin d'éviter le glissement vers l'arrière de l'utilisateur et diminuer ainsi la pression sur le milieu de la selle, soulageant la zone périnéale et améliorant ainsi le confort.



Central reservoir | Canal central

Canale centrale scavato: forma e dimensioni sono stati studiati per corrispondere alla distanza delle ossa ischiatiche per garantire un maggiore comfort.

La partie centrale de la selle présente un creu correspondant à la forme et à l'espace entre les ischions afin de garantir le meilleur confort.

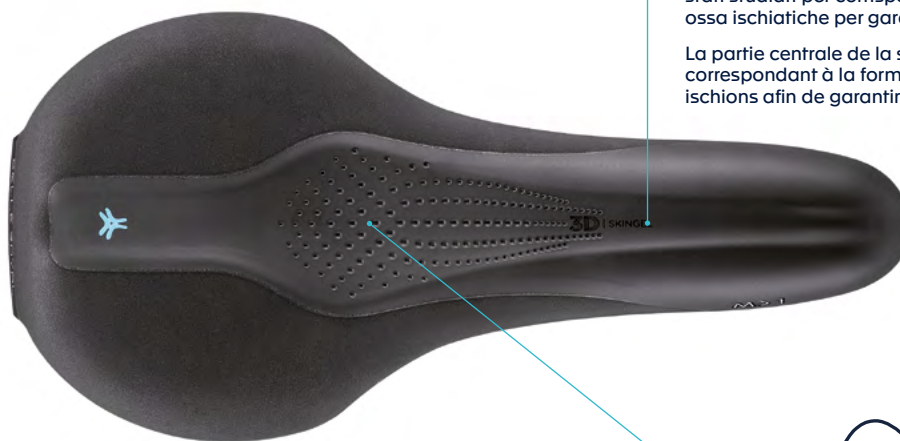

Curva suspension | Systeme d'amortissement curva

Questo esclusivo sistema di sospensione è fissato alla parte posteriore dello scafo, per offrire un comfort esclusivo evitando la pressione sui punti di contatto delle ossa ischiatiche, garantendo così una maggiore flessibilità laterale.

Ce système d'amortissement unique, est fixé sur la partie arrière de la coque. Il procure un niveau de confort optimal en éliminant la pression due au contact des ischions sur la coque, garantissant une flexibilité latérale plus importante.



3D Skingel

Royalgel™ è sapientemente posizionato in corrispondenza dei punti di contatto critici della superficie della sella, ovvero la zona di contatto dei tessuti molli, per un maggiore assorbimento degli urti.

Le Royalgel™ est positionné au niveau des divers emplacements critiques qui correspondent aux points de contact avec les tissus mous, dans le but d'absorber le moindre choc.



Measurement steps

1 Trova la tua posizione di guida Sélectionner la position de pedalage souhaitée

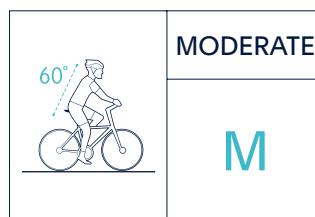

2 Determina la distanza tra le ossa ischiatiche Déterminer la largeur entre les ischions

Ripristinare lo stato di partenza del cuscinetto gel.

Réinitialisation du coussin gel.

Sedersi a 90° e tirare le impugnature laterali per esercitare pressione sulla superficie dello sgabello.

S'asseoir à 90 degrés et tirer sur les poignées afin d'augmenter la pression sur le tabouret.

Individuare i centri delle due impronte delle ossa ischiatiche e aggiungere i due numeri.

Trouver le centre de l'empreinte de chaque os d'assise sur le tabouret et ajouter les deux chiffres correspondants.

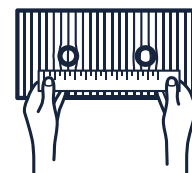
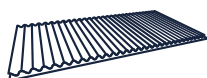

Esempio/Exemple:
5cm + 7cm = 12cm





“Supporting Cyclists” è sempre stata la mission di Selle Royal: da più di 60 anni supportiamo i ciclisti, offrendo selle e accessori di alta qualità per godere al meglio delle proprie pedalate. Ma ci piacerebbe fare di più. Per questo abbiamo trovato un modo per rendere la tua esperienza in bici ancora più piacevole.

Have a coffee while we check your bike!

Il Van di Selle Royal attraverserà l'Europa per incontrare i ciclisti e ascoltare le loro storie, con un simpatico team a bordo che offrirà caffè gratuito, un controllo della bici e un sorriso! Non importa che tipo di ciclista sei, tutti sono invitati a far parte di questa esperienza.

Segui le avventure del Van così potrai sapere dove trovarci e raggiungerci!

Soutenir les cyclistes a toujours été la mission de Selle Royal. Depuis plus de 60 ans, nous offrons aux cyclistes la meilleure conduite possible avec des selles et des accessoires abordables et de haute qualité. Mais pour nous, cela ne suffit pas. Nous avons donc trouvé une nouvelle façon de rendre votre expérience à vélo encore plus agréable.

Have a coffee while we check your bike!

Le Selle Royal Van voyage à travers l'Europe pour aller à la rencontre des cyclistes, écouter leurs histoires, offrir des cafés et des bilans techniques, le tout avec le sourire de notre équipe dédiée. Tous les cyclistes sont invités à faire partie de cette expérience, peu importe leur monture et leur manière de rouler.

Rejoignez-nous simplement en suivant les aventures du van. Vous saurez alors où nous trouver.



Have a coffee
while we check
your bike!

Selle Royal

Selle Royal

follow the van adventures on

www.selleroyal.com



ZB
990 AE



RECOVERY zone
with memory foam

SUPPORT zone

r.e.med

ACTIVE zone

RECOVERY zone
with memory foam

SUPPORT zone

r.e.med

ACT



r.e.med

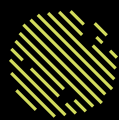

r.e.med

The ergonomic approach

Le selle **R.e.Med** sono state progettate per permettere al corpo di distribuire naturalmente lo stress in 3 zone della sella: **AZIONE**, **RECUPERO** e **SUPPORTO**, donando in questo modo sollievo e comfort, mantenendo una pressione inalterata se si cambia posizione tra il fronte ed il retro della sella.

Les selles **R.e.Med** ont été conçues pour permettre au corps de distribuer naturellement le stress sur 3 zones de la selle: **ACTION**, **RECUPERATION** et **SUPPORT**, procurant ainsi soulagement et confort même en maintenant une pression constante s'il l'on change de position par rapport au bec et à l'arrière de la selle.

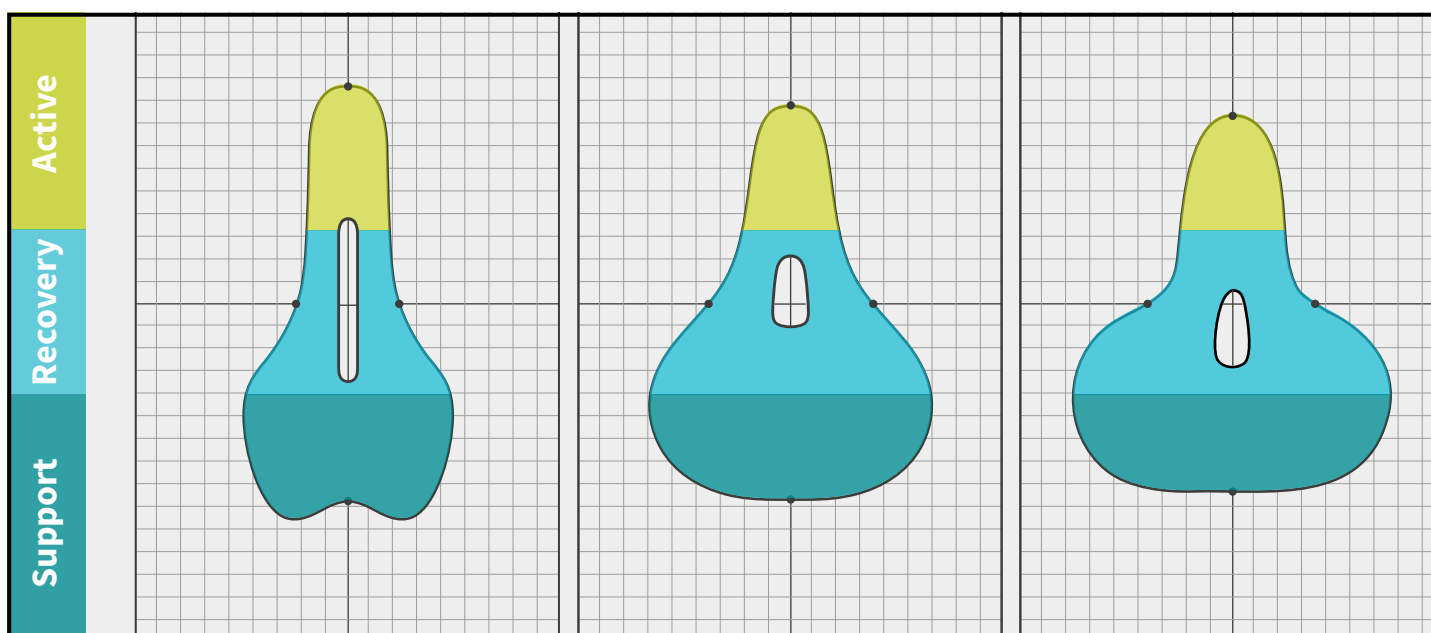

The features

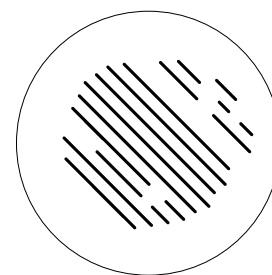
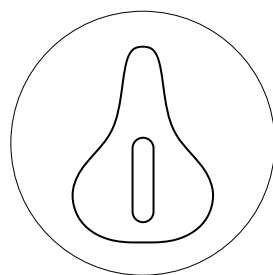
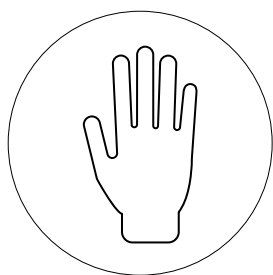
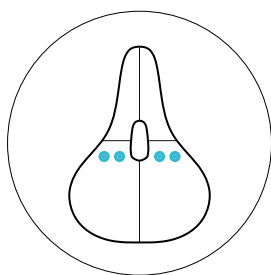

Product range



ARTICLE	EAN	NAME	RIDING POSITION	GENDER	SIZES	PRICE (€)
2354HRMA10004	6957312801471	Remed Sport	Sport	Unisex	L 287mm / W 136mm / W 316g	26,90
4309DEMA10004	6957312801488	Remed Trekking	Trekking	Unisex	L 257mm / W 189mm / W 578g	26,90
5550UEMA10003	6957312801495	Remed City	City	Unisex	L 249mm / W 207mm / W 633g	26,90

fi'zi:k







L'ambizione di **fizik** è realizzare l'attrezzatura più attraente, fascinosa e tecnica per i ciclisti più esigenti del mondo.

L'ambition de **fizik** est de créer les composants les plus attrayants, les plus fascinants, les plus techniques pour les cyclistes les plus exigeants au monde.

/fi'zi:k/

L'espressione fonetica della parola "fi'zi:k" si riferisce alla forma o allo stato del corpo umano.

L'orthographe phonétique du mot "fi'zi:k" fait référence à la forme ou à l'état du corps humain.

Alle spalle della ricca linea prodotto fizik la passione per il design e la performance nel ciclismo su strada, nel fuoristrada e nel triathlon è espressa attraverso le innumerevoli vittorie di livello professionistico e i numerosi riconoscimenti per il design, che rendono fizik la scelta degli sportivi più ambiziosi.

Che sia un nastro manubrio o dei componenti, che sia una scarpa o delle selle, fizik si impegna a fornire il design e il comfort più evoluti assieme al comfort e alla leggerezza accoppiati con la tecnologia e l'innovazione.

È attraverso studi anatomici, ricerche di fisiologia e avanzati processi tecnologici che fizik ottiene la combinazione perfetta.

Che si tratti di sfidare se stessi o gli altri corridori, che siano professionisti o amatori, se sei alla ricerca della più attraente e tecnica attrezzatura da ciclismo, la risposta è fizik.

Derrière la riche gamme de produits fizik, la passion du design et de la performance en cyclisme, sur route, tout terrain et triathlon s'expriment à travers les innombrables victoires dans les rangs professionnels, ainsi que les nombreux prix de design faisant de fizik le choix des athlètes les plus performants et ambitieux.

Qu'il s'agisse de ruban pour guidon, de composants, de chaussures ou de selles, fizik est toujours à même de réaliser le summum en matière de design, réunissant confort et légèreté associés à la technologie et l'innovation.

C'est grâce à des études anatomiques, à la recherche physiologique et des processus technologique à l'avant garde que fizik parvient à la combinaison parfaite.

Que vous lanciez un défi à vous même ou à d'autres cyclistes, professionnels ou amateurs, et que vous êtes à la recherche du matériel le plus attrayant et le plus performant, la réponse est fizik.

SERIES

Ogni ciclista in cerca di **bellezza e prestazioni**:
è per lui che Fizik progetta prodotti e con lui
che si impegna a dialogare.

Ci sono molti tipi di ciclisti, ognuno con diversi
desideri, attitudini e bisogni.

Abbiamo costruito sia la nostra gamma di
prodotti sia la nostra comunicazione intorno a
queste esigenze.

Fizik conçoit des produits pour, et s'engage
avec tous les cyclistes en quête de **beauté** et
de **performance**.

Il existe de nombreux types de cyclistes,
chacun avec des désirs, des attitudes et des
besoins différents.

Nous avons organisé notre gamme de produits
et notre communication autour de ces besoins

SERIES



VENTO

Linea RACING, disegnata in collaborazione con i ciclisti professionisti.

Ligne RACING conçue en collaboration avec des cyclistes professionnels.

DISCIPLINE/DISCIPLINES:
Road Cycling, XC, CX



TEMPO

Linea ROAD, disegnata per assicurare l'esperienza di guida più divertente e versatile.

Ligne ROAD conçue pour offrir le plaisir de pédaler dans toutes les situations.

DISCIPLINE/DISCIPLINES:
Road Riding, Randonnée



TERRA

Linea ALL-TERRAIN, disegnata per portarti oltre i tuoi limiti.

Ligne TOUT-TERRAIN conçue pour vous permettre dépasser vos limites.

DISCIPLINE/DISCIPLINES:
Gravel, All-Mountain, eMTB



GRAVITA

Linea GRAVITY, disegnata per farti scendere giù dai monti veloce e in sicurezza.

Ligne GRAVITY conçue pour dévaler la montagne à vitesse élevée, en toute maîtrise.

DISCIPLINE/DISCIPLINES:
Enduro, Downhill



TRANSIRO

Linea TRIATHLON, disegnata per prestazioni in bici senza compromessi e transizioni efficienti.

Ligne TRIATHLON conçue pour des performances à vélo optimales et des transitions efficaces.

DISCIPLINE/DISCIPLINES:
Triathlon, Ironman

SADDLES

SHAPES

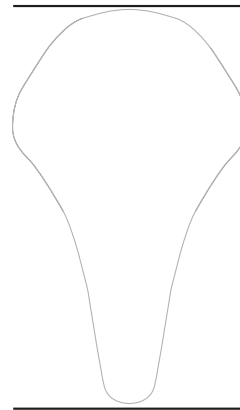

SHORT NOSE

Sella a punta corta per un posizionamento in sella confortevole e stabile, in grado di garantire una migliore distribuzione del peso e un maggiore sostegno delle ossa ischiatiche rispetto a una sella tradizionale. La sella corta permette al ciclista di sedersi in posizione più avanzata senza sottoporre a pressioni eccessive le aree sensibili.

Une selle à bec court place le cycliste dans une position plus ancrée, ce qui permet une plus grande stabilité, une meilleure répartition du poids et un soutien ischiatique plus généreux par rapport à une selle traditionnelle. La selle courte permet au cycliste de s'asseoir plus en avant sans exercer une pression excessive sur les tissus sensibles.

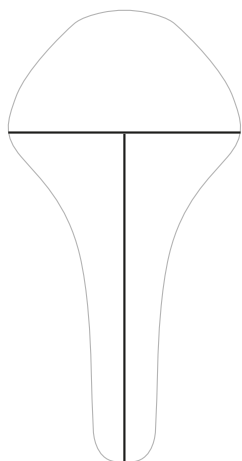

T-SHAPE

Una sella ad alte prestazioni dalla forma aerodinamica e affusolata. Progettata per garantire la massima reattività in ogni condizione di gara.

Une selle haute performance avec une forme profilée et une transition bec-bords effilée. Conçue pour permettre une sensation de réactivité dans toutes les conditions de course.

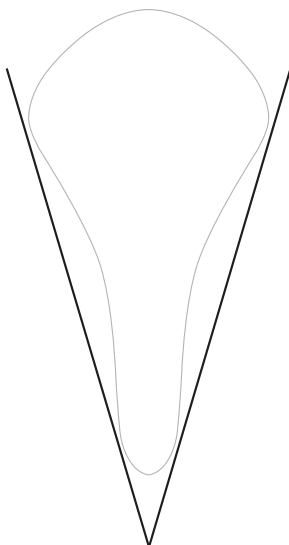

V-SHAPE

Sella caratterizzata da una transizione graduale e affusolata da coda a punta. Con una base di appoggio leggermente più ampia per sostenere le ossa ischiatiche.

Une selle qui présente une transition graduelle et effilée des bords au bec. Avec une plateforme légèrement plus large pour soutenir les os ischiatiques.

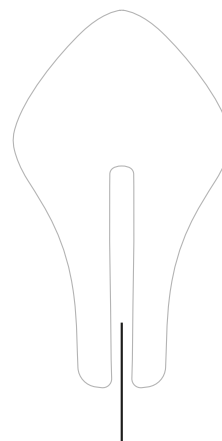

SPLIT NOSE

Sella con punta doppia. Le due metà indipendenti costituiscono un sistema di scarico della pressione senza precedenti, pur garantendo il sostegno e l'equilibrio necessari per affrontare lunghe ore in posizione aerodinamica.

Selle conçue avec un nez divisé. Les deux moitiés indépendantes permettent un système d'allègement de la pression sans précédent tout en continuant à maintenir le soutien ferme et l'équilibre nécessaires pour de longues heures passées en position aérodynamique.

SURFACES

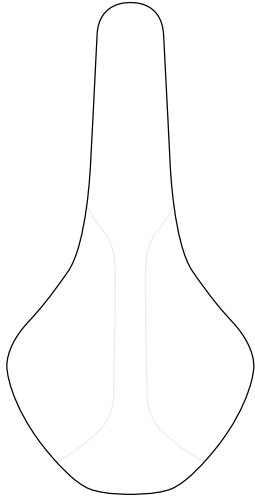

SOLID

Costruzione handmade per una trasmissione di potenza ottimale, unita a un'imbottitura resiliente che distribuisce anche il peso del corpo.

Une fabrication artisanale pour un transfert de puissance optimal accouplé à un rembourrage élastique favorisant une répartition uniforme du poids du corps.

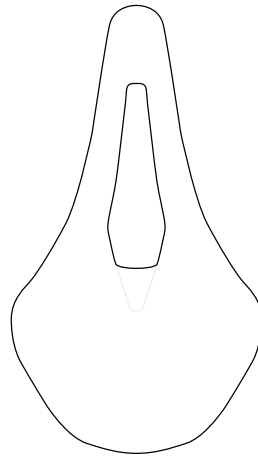

CUT-OUT

Taglio ergonomico, sviluppato usando dettagliate analisi di pressione e input di esperti in medicina, che scarica la pressione sui tessuti molli.

La découpe ergonomique, développée à partir d'une analyse détaillée de la pression et des conclusions d'experts médicaux, permet de soulager la pression sur les tissus mous.

RAILS

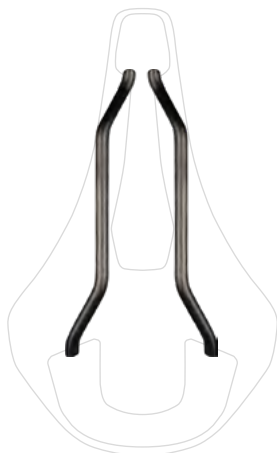

CARBON

Al posto di quello convenzionale in tubo solido o cavo, i telai fizik utilizzano un rivestimento esterno di carbonio intrecciato che forma un tubo internamente cavo realizzato con fibre di carbonio unidirezionale. È una costruzione robusta, leggera e rigida.

Au lieu du conventionnel tube plein ou creux, les rails fizik sont réalisés à partir de fibres de carbone unidirectionnelles tressées formant un tube intérieur creux. C'est une construction robuste, légère et rigide.

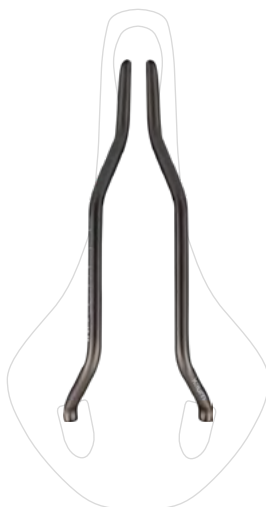

KIUM

Kium è il risultato di una particolare lega metallica unita a un design specifico a tubolare e a uno speciale processo di finitura che aumenta la resistenza del binario. Ciò consente di ridurre il peso dell'8% rispetto al titanio solido, garantendo un elevato rapporto forza-peso e un'alta resistenza alla corrosione.

Kium est la combinaison d'un alliage métallique particulier, d'une conception tubulaire spécifique et d'un processus de finition spécial qui augmente la résistance à la fatigue du rail. Cela permet un gain de poids de 8 % par rapport au titane plein, garantissant un compromis élevé entre robustesse et légèreté et haute résistance à la corrosion.

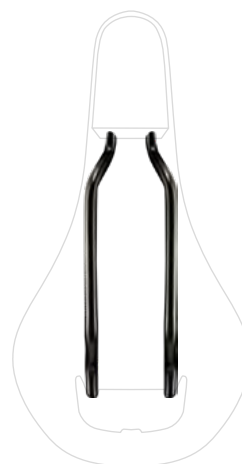

S-ALLOY

Questa lega metallica è una miscela brevettata a base di ferro, carbonio (0,2%) e altri minerali, come cromo e molibdeno. Il basso contenuto di carbonio, combinato a uno specifico trattamento di finitura, consente di ottenere un binario robusto e altamente resistente alla corrosione.

Cet alliage métallique spécifique est un composé exclusif d'acier, de carbone (0,2%) et d'autres minéraux tels le chrome et le molybdène. La faible teneur en carbone associée à un traitement de surface spécifique procure au rail une résistance élevée à la corrosion.

ROAD AND TRIATHLON SADDLES

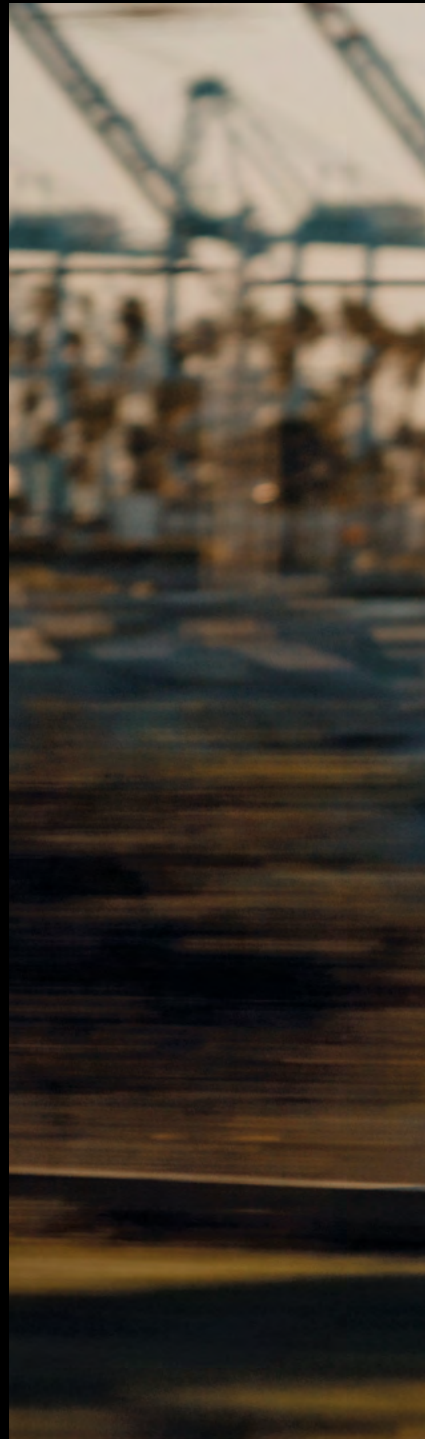



VENTO ARGO ADAPTIVE

Una sella performante, a punta corta, che presenta la rivoluzionaria struttura Adaptive stampata in 3D, per offrire un comfort migliorato e maggiore stabilità, grazie a zone di assorbimento specifiche.

Une selle performante à nez court dotée du rembourrage révolutionnaire 3D-printed Adaptive pour un amorti zonal sans faille, un confort amélioré et une plus grande stabilité.



VENTO
ARGO 00
ADAPTIVE

Intended use: ROAD RACING

Regular
L 265mm | W 140mm | W 175g
Large
L 265mm | W 150mm | W 186g



VENTO
ARGO R1
ADAPTIVE

Intended use: ROAD RACING, XC, CX

Regular
L 265mm | W 140mm | W 190g
Large
L 265mm | W 150mm | W 196g



VENTO
ARGO R3
ADAPTIVE

Intended use: ROAD RACING, XC, CX

Regular
L 265mm | W 140mm | W 224g
Large
L 265mm | W 150mm | W 230g



ARTICLE	EAN	MODEL	SIZE	COLOR	RAILS	SHELL	PADDING	SRP (€)
77F1D00A0P003	8021890583536	Vento Argo 00 Adaptive	140mm	Black	Carbon Mobius 7x9mm	Full Carbon	Adapitve padding	399
77F2D00A0P003	8021890583543		150mm					399
70F1D00A0P002	8021890571090	Vento Argo R1 Adaptive	140mm	Black	Carbon 7x9mm	Carbon Reinforced Nylon with WingFlex	Adapitve padding	299
70F2D00A0P002	8021890571113		150mm					299
70F1D00A1P002	8021890571106	Vento Argo R3 Adaptive	140mm	Black	Kium 7x7mm	Carbon Reinforced Nylon with WingFlex	Adapitve padding	259
70F2D00A1P002	8021890571120		150mm					259

VENTO ARGO

Vento Argo è stata sviluppata per ottenere una sensazione di riding che si adatta alle bici da corsa con una geometria aggressiva.

Il deliberato obiettivo del suo design ti aiuta ad ottenere un migliore assetto: il naso ribassato supporta il ramo pubico quando le pelvi ruotano in avanti per aumentare la potenza oppure per una posizione più aero.

Vento Argo a été conçue pour offrir la sensation de guidage qui convient aux vélos de course à géométrie agressive.

La forme spécifique de sa conception aide à obtenir la meilleur position de guidage: le nez plongeant soutient la branche pubienne lorsque le bassin pivote vers l'avant pour gagner de la puissance et obtenir plus d'aérodynamisme.



VENTO
ARGO 00

Intended use: ROAD RACING

Regular

L 265mm | W 140mm | W 134g

Large

L 265mm | W 150mm | W 139g



VENTO
ARGO R1

Intended use: ROAD RACING

Regular

L 265mm | W 140mm | W 179g

Large

L 265mm | W 150mm | W 186g



VENTO
ARGO R3

Intended use: ROAD RACING

Regular

L 265mm | W 140mm | W 213g

Large

L 265mm | W 150mm | W 220g



VENTO
ARGO R5

Intended use: ROAD RACING

Regular

L 265mm | W 140mm | W 225g

Large

L 265mm | W 150mm | W 232g



ARTICLE	EAN	MODEL	SIZE	COLOR	RAILS	SHELL	PADDING	SRP (€)
77D7Y00A0E000	8021890499271	Vento Argo 00	140mm	Black	Carbon Mobius 7x9mm	Full Carbon	EVA padding	299
77D8Y00A0E000	8021890499288		150mm					299
70D7S00A03A23	8021890486486	Vento Argo R1	140mm	Black	Carbon 7x9mm	Carbon Reinforced Nylon with WingFlex	Type 1	199
70D8S00A03A23	8021890486516		150mm					199
70D7S00A13A22	8021890486493	Vento Argo R3	140mm	Black	Kium 7x7mm	Carbon Reinforced Nylon with WingFlex	Type 1	149
70D8S00A13A22	8021890486523		150mm					149
70D7S00A23A22	8021890486509	Vento Argo R5	140mm	Black	S-Alloy 7x7mm	Carbon Reinforced Nylon with WingFlex	Type 1	109
70D8S00A23A22	8021890486530		150mm					109

TEMPO ARGO

Come opzione per la guida endurance Tempo Argo è stata sviluppata per assicurare una sensazione di marcia adatta per la geometria equilibrata che contraddistingue le versatili biciclette da corsa attuali.

L'imbottitura è leggermente più sottile attorno all'area delle prominenze ischiatiche al fine di supportare una posizione di guida più eretta, assicurando maggiore comfort sulle lunghe distanze.

En option pour la pratique d'endurance, Tempo Argo a été développée pour assurer une perception adaptée à la géométrie équilibrée qui caractérise les vélos de course polyvalents d'aujourd'hui.

Le rembourrage est plus fin autour des zones des proéminences ischiatiques afin de soutenir une position de pédalage plus droite, assurant un plus grand confort sur de longues distances.

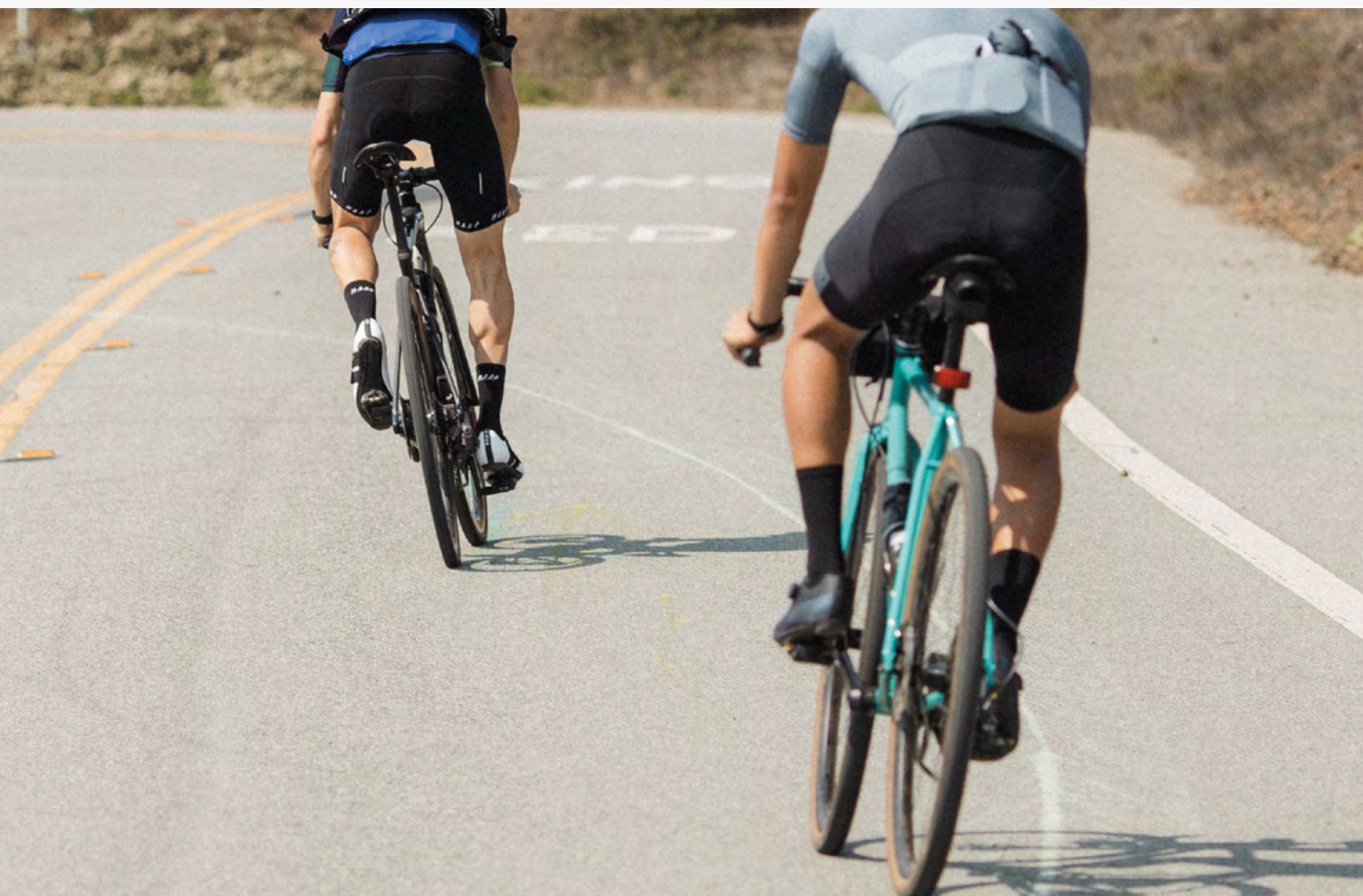

TEMPO
ARGO R1

Intended use: ROAD

Regular

L 260mm | W 150mm | W 195g

Large

L 260mm | W 160mm | W 202g



TEMPO
ARGO R3

Intended use: ROAD

Regular

L 260mm | W 150mm | W 229g

Large

L 260mm | W 160mm | W 235g



TEMPO
ARGO R5

Intended use: ROAD

Regular

L 260mm | W 150mm | W 241g

Large

L 260mm | W 160mm | W 247g



ARTICLE	EAN	MODEL	SIZE	COLOR	RAILS	SHELL	PADDING	SRP (€)
70D9S00A03A23	8021890486547	Tempo Argo R1	150mm	Black	Carbon Mobius 7x9mm	Carbon Reinforced Nylon with WingFlex	Type 2	199
70E0S00A03A23	8021890486578		160mm					199
70D9S00A13A22	8021890486554	Tempo Argo R3	150mm	Black	Kium 7x7mm	Carbon Reinforced Nylon with WingFlex	Type 2	149
70E0S00A13A22	8021890486585		160mm					149
70D9S00A23A22	8021890486561	Tempo Argo R5	150mm	Black	S-Alloy 7x7mm	Carbon Reinforced Nylon with WingFlex	Type 2	109
70E0S00A23A22	8021890486592		160mm					109

ANTARES

Sella ad alte prestazioni con una forma aerodinamica e una transizione naso-ala affusolata, progettata per garantire reattività in ogni condizione di gara.

Une selle haute performance avec une forme profilée et une transition bec/bords effilée, conçue pour offrir une sensation de réactivité dans toutes les conditions de course.



VENTO
ANTARES 00

Intended use: ROAD RACING, XC, CX

Regular

L 270mm | W 140mm | W 118g

Large

L 270mm | W 150mm | W 124g



VENTO
ANTARES R1

Intended use: ROAD RACING, XC, CX

Regular

L 268mm | W 140mm | W 161g

Large

L 268mm | W 150mm | W 166g



VENTO
ANTARES R3

Intended use: ROAD RACING, XC, CX

Regular

L 268mm | W 140mm | W 195g

Large

L 268mm | W 150mm | W 202g



VENTO
ANTARES R5

Intended use: ROAD RACING, XC, CX

Regular

L 268mm | W 140mm | W 210g

Large

L 268mm | W 150mm | W 217g



ARTICLE	EAN	MODEL	SIZE	COLOR	RAILS	SHELL	PADDING	SRP (€)
77E9Y00A0E000	8021890580375	Vento Antares 00	140mm	Black	Carbon 7x9mm	Full Carbon Shell	Injected EVA	299
77F0Y00A0E000	8021890580382		150mm					299
75E5S00A03A25	8021890580191	Vento Antares R1	140mm	Black	Carbon 7x9mm	Carbon Reinforced Nylon with WingFlex	Double-density foam	199
75E6S00A03A25	8021890580221		150mm					199
75E5S00A13A25	8021890580207	Vento Antares R3	140mm	Black	Kium 7x7mm	Carbon Reinforced Nylon with WingFlex	Double-density foam	149
75E6S00A13A25	8021890580238		150mm					149
75E5S00A23A25	8021890580214	Vento Antares R5	140mm	Black	S-Alloy 7x7mm	Carbon Reinforced Nylon with WingFlex	Double-density foam	109
75E6S00A23A25	8021890580245		150mm					109

ALIANTE

Aliante è una sella da ciclismo su strada endurance dal profilo ondulato, dotata di foro per alleviare la pressione e schiuma a doppia densità per il massimo del comfort anche durante le uscite più lunghe.

L'Aliante est une selle de vélo de route d'endurance avec un profil ondulé conçu pour maximiser le confort, avec une découpe d'allégement de la pression et une mousse à double densité qui rendent les sorties les plus longues agréables.



TEMPO
ALIANTE R1

Intended use: ROAD

Regular

L 277mm | W 145mm | W 180g

Large

L 277mm | W 155mm | W 186g



TEMPO
ALIANTE R3

Intended use: ROAD

Regular

L 277mm | W 145mm | W 220g

Large

L 277mm | W 155mm | W 226g



TEMPO
ALIANTE R5

Intended use: ROAD

Regular

L 277mm | W 145mm | W 230g

Large

L 277mm | W 155mm | W 236g



ARTICLE	EAN	MODEL	SIZE	COLOR	RAILS	SHELL	PADDING	SRP (€)
75E7S00A03A25	8021890580252	Tempo Aliante R1	145mm	Black	Carbon 7x9mm	Carbon Reinforced Nylon with WingFlex	Double-density foam	199
75E8S00A03A25	8021890580283		155mm					199
75E7S00A13A25	8021890580269	Tempo Aliante R3	145mm	Black	Kium 7x7mm	Carbon Reinforced Nylon with WingFlex	Double-density foam	149
75E8S00A13A25	8021890580290		155mm					149
75E7S00A23A25	8021890580276	Tempo Aliante R5	145mm	Black	S-Alloy 7x7mm	Carbon Reinforced Nylon with WingFlex	Double-density foam	109
75E8S00A23A25	8021890580306		155mm					109

ARIONE

Una sella con profilo piatto progettata per ciclisti con elevata flessibilità del corpo e senza rotazione pelvica durante la pedalata.

Une selle à profil plat conçue pour les cyclistes ayant une grande flexibilité corporelle et sans rotation du bassin pendant le pédalage.



ARIONE 00

Intended use: ROAD RACING

L 298mm | W 124mm | W 140g



ARIONE R1

Intended use: ROAD RACING

Regular

L 300mm | W 126mm | W 165g

Large

L 300mm | W 140mm | W 175g



ARIONE R3

Intended use: ROAD RACING

Regular

L 300mm | W 126mm | W 200g

Large

L 300mm | W 140mm | W 210g



ARIONE CLASSIC

Intended use: ROAD RACING

L 300mm | W 132mm | W 235g



ARTICLE	EAN	MODEL	SIZE	COLOR	RAILS	SHELL	PADDING	SRP (€)
7092SWSA19C65	8021890428127	Arione 00	-	Black/ Anthracite	Carbon Mobius 7x10mm	Full Carbon	Type 1	299
76B5SWSA09C65	8021890443861	Arione R1	Regular	Black	Carbon Braided 7x10mm	Thermoplastic Carbon Composite with WingFlex	Type 1	199
76BOSWSA09E12	8021890443830		Large					199
74B5SWSA09F04	8021890443816	Arione R3	Regular	Black	Kium 7x7mm	Thermoplastic Carbon Composite with WingFlex	Type 1	149
74BOSWSA09C65	8021890443786		Large					149
7014SXSD99640	8021890276308	Arione Classic	-	Black	Kium 7x7mm	Carbon Reinforced Nylon with WingFlex	Type 1	129

ARIONE OPEN

Open è una costruzione fatta a mano per un trasferimento di potenza ottimale unito con un design spaccato che scarica la pressione sui tessuti molli.

Open une fabrication artisanale pour une transmission de puissance optimale associée à une conception en deux parties qui soulage la pression sur les tissus mous.



ARIONE R1 OPEN

Intended use: ROAD RACING

Regular

L 300mm | W 132mm | W 199g

Large

L 298mm | W 142mm | W 205g



ARIONE R3 OPEN

Intended use: ROAD

Regular

L 300mm | W 132mm | W 230g

Large

L 298mm | W 142mm | W 240g



ARTICLE	EAN	MODEL	SIZE	COLOR	RAILS	SHELL	PADDING	SRP (€)
70COS00A03A02	8021890455642	Arione R1 Open	Regular	Black	Carbon Braided 7x10mm	Carbon Reinforced Nylon with WingFlex	Type 1	199
70DOS00A03A02	8021890455703		Large					199
70COS00A13041	8021890455659	Arione R3 Open	Regular	Black	Kium 7x7mm	Carbon Reinforced Nylon with WingFlex	Type 1	149
70DOS00A13041	8021890455710		Large					149
70COS00A13038	8021890460233	Arione R3 Open	Regular	White	Kium 7x7mm	Carbon Reinforced Nylon with WingFlex	Type 1	149
70DOS00A13038	8021890460264		Large					149

AERIS LONG DISTANCE

Una sella da triathlon a naso sdoppiato progettata per fornire maggiore sostegno e stabilità quando si pedala in posizioni di guida avanzate e aerodinamiche.

Une selle de triathlon à bec divisé, conçue pour offrir un meilleur soutien et une plus grande stabilité lors des courses en position avancée et aérodynamique.



TRANSIRO
AERIS LD R1

Intended use: TRIATHLON / TIME TRIAL

L 244mm | W 135mm | W 181g



TRANSIRO
AERIS LD R3

Intended use: TRIATHLON / TIME TRIAL

L 244mm | W 135mm | W 212g



TRANSIRO
AERIS LD R5

Intended use: TRIATHLON / TIME TRIAL

L 244mm | W 135mm | W 218g



ARTICLE	EAN	MODEL	SIZE	COLOR	RAILS	SHELL	PADDING	SRP (€)
75F3S00A03A25	8021890580313	Transiro AERIS LD R1	135mm	Black	Carbon 7x9mm	Carbon Reinforced Nylon	Type 1	199
75F3S00A13A25	8021890580320	Transiro AERIS LD R3	135mm	Black	Kium 7x7mm	Carbon Reinforced Nylon	Type 1	149
75F3S00A23A25	8021890580337	Transiro AERIS LD R5	135mm	Black	S-Alloy 7x7mm	Carbon Reinforced Nylon	Type 1	109

AERIS SHORT DISTANCE

Una sella che favorisce massima stabilità e supporto a chi gareggia nelle competizioni a cronometro e di triathlon e cerca una piattaforma ottimale da cui erogare potenza in posizioni di guida avanzate e aerodinamiche.

Selle conçue pour offrir une stabilité et un soutien maximum aux coureurs de contre-la-montre et aux triathlètes qui ont besoin d'une plateforme optimale pour délivrer leur puissance dans des positions de conduite aérodynamiques et avancées.



TRANSIRO
AERIS SD R1

Intended use: TRIATHLON / TIME TRIAL

L 245mm | W 135mm | W 170g



TRANSIRO
AERIS SD R3

Intended use: TRIATHLON / TIME TRIAL

L 245mm | W 135mm | W 199g



TRANSIRO
AERIS SD R5

Intended use: TRIATHLON / TIME TRIAL

L 245mm | W 135mm | W 209g



ARTICLE	EAN	MODEL	SIZE	COLOR	RAILS	SHELL	PADDING	SRP (€)
75F4S00A03A25	8021890580344	Transiro Aeris SD R1	135mm	Black	Carbon 7x9mm	Carbon Reinforced Nylon	Type 1	199
75F4S00A13A25	8021890580351	Transiro Aeris SD R3	135mm	Black	Kium 7x7mm	Carbon Reinforced Nylon	Type 1	149
75F4S00A23A25	8021890580368	Transiro Aeris SD R5	135mm	Black	S-Alloy 7x7mm	Carbon Reinforced Nylon	Type 1	109

OFF-ROAD SADDLES





VENTO ARGO X NEW

Una sella off-road performante con un design a punta corta che migliora la stabilità e consente una posizione di guida più aggressiva.

Une selle de course tout-terrain performante avec un nez court qui améliore la stabilité et permet une position de conduite plus agressive.



VENTO
ARGO X1

Intended use: OFF-ROAD RACING

Regular

L 265mm | W 140mm | W 192g

Large

L 265mm | W 150mm | W 198g



VENTO
ARGO X3

Intended use: OFF-ROAD RACING

Regular

L 265mm | W 140mm | W 231g

Large

L 265mm | W 150mm | W 237g



VENTO
ARGO X5

Intended use: OFF-ROAD RACING

Regular

L 265mm | W 140mm | W 240g

Large

L 265mm | W 150mm | W 246g



ARTICLE	EAN	NEW	MODEL	SIZE	COLOR	RAILS	SHELL	PADDING	SRP (€)
F212URNA27881	6957312803291	NEW	Vento Argo X1	140mm	Black	Carbon 7x9mm	Fiber Reinforced Nylon with WingFlex	Type 1	199
F213URNA27881	6957312803314	NEW		150mm					199
F212URNA17881	6957312803277	NEW	Vento Argo X3	140mm	Black	Kium 7x7mm	Fiber Reinforced Nylon with WingFlex	Type 1	149
F213URNA17881	6957312803284	NEW		150mm					149
F212URNA07881	6957312803253	NEW	Vento Argo X5	140mm	Black	S-Alloy 7x7mm	Fiber Reinforced Nylon with WingFlex	Type 1	109
F213URNA07881	6957312803260	NEW		150mm					109

TERRA ARGO

Come opzione per le gravel bike, la Terra Argo è stata sviluppata con un particolare scafo che offre un certo grado di flessibilità.

Questa elasticità controllata assorbe le buche e le vibrazioni della strada, assicurando il comfort necessario per le uscite di lunga distanza, su strade non asfaltate.

En option pour les vélos gravel, la Terra Argo a été développée avec une coque particulière qui offre une certaine flexibilité.

Cette élasticité contrôlée absorbe les nids-de-poule et les vibrations de la route, assurant le confort nécessaire pour les longues distances, sur les routes non goudronnées.



TERRA
ARGO X1

Intended use: GRAVEL

NEW SIZE

L 270mm | W 140mm | W 210g

Regular

L 270mm | W 150mm | W 215g

Large

L 270mm | W 160mm | W 225g



TERRA
ARGO X3

Intended use: GRAVEL

NEW SIZE

L 270mm | W 140mm | W 253g

Regular

L 270mm | W 150mm | W 258g

Large

L 270mm | W 160mm | W 262g



TERRA
ARGO X5

Intended use: GRAVEL

NEW SIZE

L 270mm | W 140mm | W 265g

Regular

L 270mm | W 150mm | W 271g

Large

L 270mm | W 160mm | W 275g



ARTICLE	EAN	NEW	MODEL	SIZE	COLOR	RAILS	SHELL	PADDING	SRP (€)
70F9S00A03A22	8021890590077	NEW	Terra Argo X1	140mm	Black	Carbon 7x9mm	Carbon Reinforced Nylon with WingFlex	Type 2	199
70E1S00A23A22	8021890571199			150mm					199
70E2S00A23A22	8021890571205			160mm					199
70F9S00A13A22	8021890590084	NEW	Terra Argo X3	140mm	Black	Kium Mobius 7x7mm	Carbon Reinforced Nylon with WingFlex	Type 2	149
70E1S00A03A22	8021890498052			150mm					149
70E2S00A03A22	8021890498076			160mm					149
70F9S00A23A22	8021890590091	NEW	Terra Argo X5	140mm	Black	S-Alloy Mobius 7x7mm	Carbon Reinforced Nylon with WingFlex	Type 2	109
70E1S00A13A22	8021890486615			150mm					109
70E2S00A13A22	8021890486639			160mm					109

ALPACA

Una sella da mountain bike con una forma dal bordo arrotondato, da utilizzare in combinazione con il reggisela telescopico, che unisce supporto e controllo della bici.

Une selle de VTT avec une forme à bords lisses qui combine le soutien et le contrôle de la conduite pour l'utilisation de la tige de selle télescopique.



TERRA
ALPACA X5
+ CARRIAGE KIT

Intended use: ENDURO, ALL-MOUNTAIN

L 248mm | W 145mm | W 230g



GRAVITA
ALPACA X5
+ CARRIAGE KIT

Intended use: ENDURO, DOWNHILL

L 251mm | W 130mm | W 216g

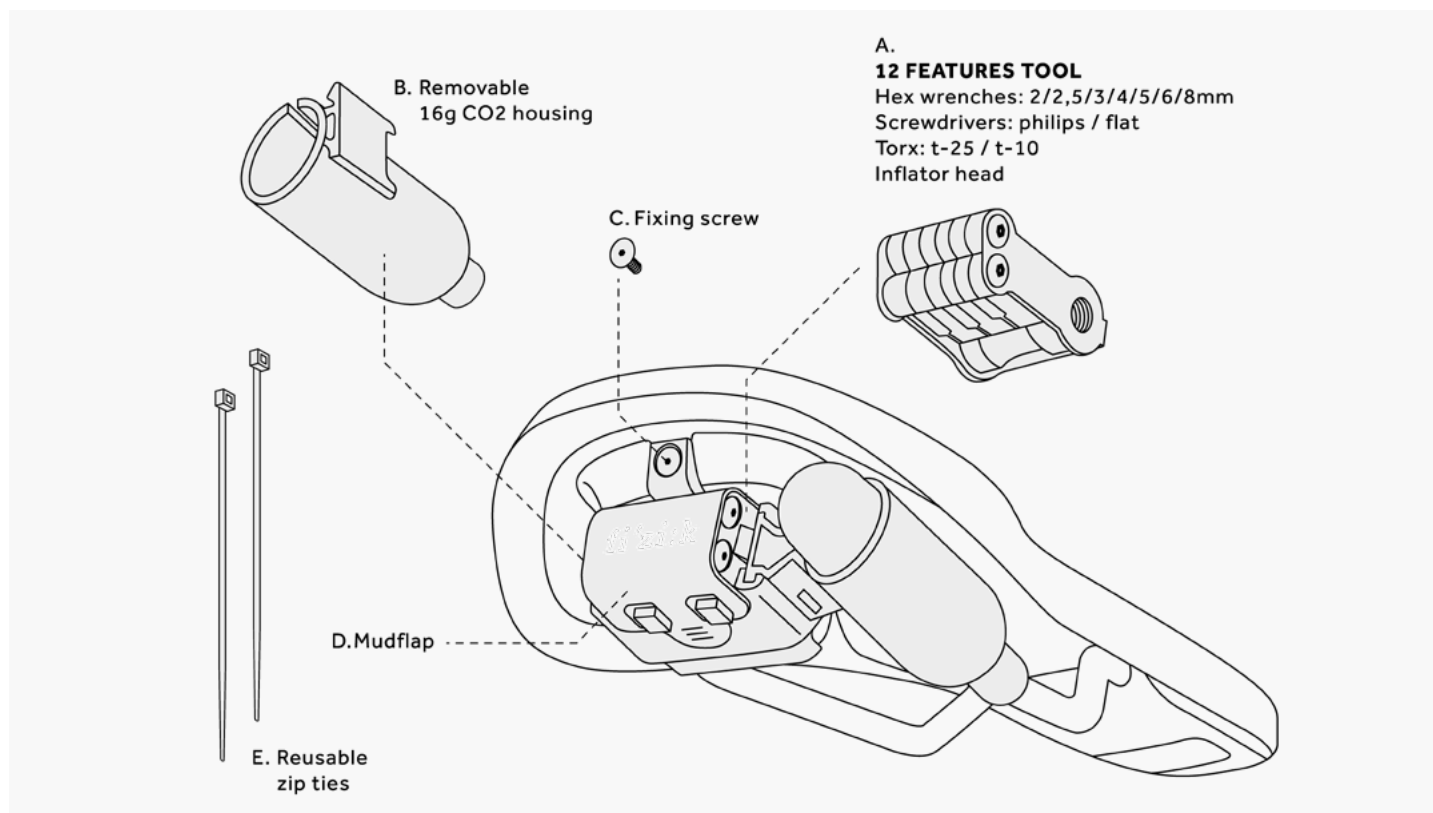

ARTICLE	EAN	MODEL	COLOR	RAILS	SHELL	PADDING	SRP (€)
F206URNA13814	6957312802447	Terra Alpaca X5 + Carriage Kit	Black	S-Alloy Mobius 7x7mm	Fiber Reinforced Nylon with EdgeFlex	Type 1	109
F205URNA13814	6957312802430	Gravita Alpaca X5 + Carriage Kit	Black	S-Alloy Mobius 7x7mm	Fiber Reinforced Nylon with EdgeFlex	Type 1	99

AIDON

Aidon è una sella progettata per soddisfare le esigenze della pedalata assistita.

Aidon est une forme de selle conçue pour répondre aux besoins de l'assistance au pédalage.



TERRA
AIDON X1

Intended use: E-MTB

Regular

L 255mm | W 145mm | W 205g

Large

L 255mm | W 160mm | W 215g



TERRA
AIDON X3

Intended use: E-MTB

Regular

L 255mm | W 145mm | W 249g

Large

L 255mm | W 160mm | W 259g



TERRA
AIDON X5

Intended use: E-MTB

Regular

L 255mm | W 145mm | W 262g

Large

L 255mm | W 160mm | W 272g



ARTICLE	EAN	MODEL	SIZE	COLOR	RAILS	SHELL	PADDING	SRP (€)
F208URNA24873	6957312802485	Terra Aidon X1	145mm	Black	Carbon Mobius 7x9mm	Fiber Reinforced Nylon with WingFlex	Type 2	179
F209URNA24873	6957312802515		160mm					179
F208URNA14873	6957312802478	Terra Aidon X3	145mm	Black	Kium Mobius 7x7mm	Fiber Reinforced Nylon with WingFlex	Type 2	139
F209URNA14873	6957312802508		160mm					139
F208URNA04873	6957312802461	Terra Aidon X5	145mm	Black	S-Alloy Mobius 7x7mm	Fiber Reinforced Nylon with WingFlex	Type 2	89
F209URNA04873	6957312802492		160mm					89

VENTO
ANTARES
TEST KIT

1 Vento Antares R5 140
 1 Vento Antares R5 150



TEMPO
ALIANTE
TEST KIT

1 Tempo Aliante R5 145
 1 Tempo Aliante R5 155



TRANSIRO
AERIS
TEST KIT

1 Transiro Aeris SD R5
 1 Transiro Aeris LD R5



VENTO & TEMPO
ARGO
TEST KIT

1 Vento Argo R3 140
 1 Vento Argo R3 150
 1 Tempo Argo R3 150
 1 Tempo Argo R3 160



TERRA
ARGO
TEST KIT

1 Terra Argo X3 150
 1 Terra Argo X3 160



ARTICLE	EAN	MODEL	DESCRIPTION
FZKS000D30000	8021890580399	Vento Antares Test Kit	2 Vento Antares R5, both sizes, test cosmetics
FZKS000D40000	8021890580405	Tempo Aliante Test Kit	2 Tempo Aliante R5, both sizes, test cosmetics
FZKS000D50000	8021890580412	Transiro Aeris Test Kit	1x Transiro Aeris SD R5 and 1x Transiro Aeris LD R5, test cosmetics
FZKS000000000	8021890486448	Vento & Tempo Argo Test Kit	4 R3 Vento e Tempo Argo Test Saddles (2 Regular + 2 Large)
FZKS000C50000	8021890498397	Terra Argo Test Kit	2 X3 Terra Argo Test Saddles (1 Regular + 1 Large)

SADDLE BAG SMALL

Disegnata per alloggiare una camera d'aria, una cartuccia di CO2 e i levagomme.

Realizzata in durevole PU-rivestito in poliestere con cuciture saldate.

- Tasca interna in rete
- Zip idrorepellente
- Si aggancia sotto la sella con uno strap Velcro
- Volume di 0,4 litri
- Dimensioni 110x75x50 mm
- Peso: 66g

Conçu pour contenir une chambre à air, une cartouche de CO2 et les démonte pneus.

Fabriqué en polyester durable enduit de PU avec coutures soudées.

- Poche intérieure en filet
- Zip déperlant
- Il s'accroche sous la selle avec une sangle Velcro
- Volume de 0,4 litre
- Dimensions 110x75x50 mm
- Poids: 66g



AERIS LINK

NEW

Weight: 14g

Permette l'attacco posteriore di un portaborraccia alle selle Aeris SD e LD.

Permet de fixer un porte-bidon à l'arrière des selles Aeris SD et LD.



BOTTLE CAGE

Weight: 29g

Portaborraccia progettato per essere integrato alla sella Aeris, compatibile con tutti i supporti standard con filettatura a 2 fori.

Développé pour être intégré au maillon de la selle Aeris, ce porte-bidon est compatible avec tous les supports standards à 2 trous.



ARTICLE	EAN	NEW	MODEL	SIZE	COLOR	DESCRIPTION	SRP (€)
FB09000A00000	8021890497130		fi'zi:k Saddle Bag	One Size	Black	PU-coated polyester / inner mesh pocket / water repellent zipper / velcro straps	25
FZKS000D70000	8021890586698	NEW	fi'zi:k Aeris Link	One Size	Black	Enables rear attachment of a water bottle cage to Aeris SD and LD saddles	15
FZKS000D20000	8021890497130		fi'zi:k Bottle Cage	One Size	Black	Designed to be integrated with the Aeris saddle link, the bottle cage is compatible with all bike frames with standard 2 threaded holes	15

SADDLE FINDER

Noi di fizik vogliamo fornirti la migliore esperienza di guida possibile, ottimizzando salute, comfort e prestazioni.

Per aiutarti a **scegliere la tua sella ideale** abbiamo creato un semplice strumento che ti guida nel processo di scelta.

Chez fizik, nous croyons qu'il faut offrir la meilleure expérience de pilotage possible, en améliorant la santé, le confort et les performances.

Pour vous aider à **choisir votre selle idéale**, nous avons créé un outil simple qui vous guidera tout au long du processus.

Scopri di più su www.fizik.com
o scansiona il codice.

Pour en savoir plus, consultez le site
www.fizik.com ou scannez le code.



SHOES

CLOSURE SYSTEMS

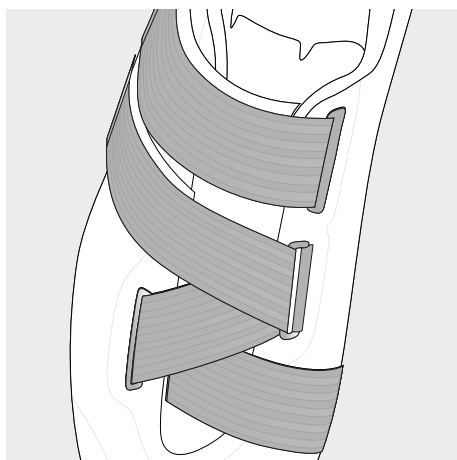

POWERSTRAP

È un'innovativa chiusura Velcro disegnata per una calzata avvolgente. Mentre la maggior parte delle chiusure Velcro tengono semplicemente assieme due lati della tomaia, in questo caso un nastro si avvolge attorno al piede, garantendo un comfort e un contenimento superiori utilizzando solo due straps.

Il s'agit d'une fermeture Velcro innovante conçue pour un ajustement parfait. Alors que la plupart des fermetures Velcro maintiennent simplement deux côtés de la tige ensemble, dans ce cas, un ruban s'enroule autour du pied, assurant un confort et un ajustement supérieurs en utilisant seulement deux sangles.

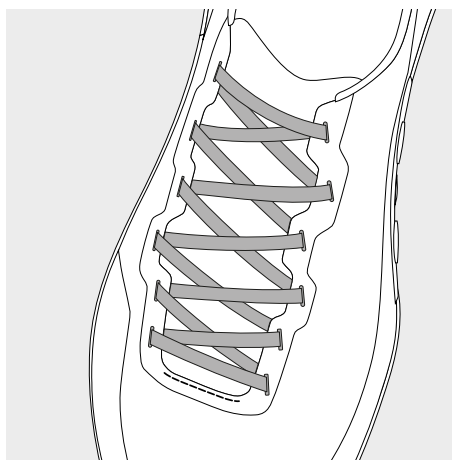

LACE

I lacci avvolgono il piede e si adattano alla sua forma, assicurando una calzata naturale. In questo modo, la pressione viene distribuita in modo uniforme su tutto il piede, evitando la formazione di punti critici.

Les lacets enveloppent le pied et s'adaptent à une variété de formes de pieds, sécurisant l'ajustement avec une sensation plus naturelle. Avec les lacets, la pression est répartie uniformément sur l'ensemble du pied, sans créer de points de chaleur.

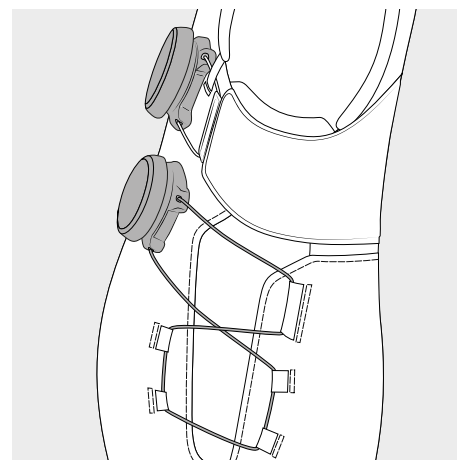

DOUBLE BOA

Permette di regolare separatamente la calzata per le aree del collo del piede e dell'avampiede, la cui forma e volume possono variare notevolmente da un ciclista all'altro. Attraverso il controllo di due chiusure BOA indipendenti, il ciclista può regolare con precisione la calzata della scarpa in base alla forma del proprio piede, per comfort e sostegno personalizzati.

Permet un réglage différencié de l'ajustement pour les zones du cou-de-pied et de l'avant-pied, dont la forme et le volume peuvent varier considérablement d'un cycliste à l'autre. En contrôlant les deux cadrans BOA distincts, les cyclistes peuvent adapter la chaussure à la forme unique de leur pied pour un confort et un soutien personnalisés.

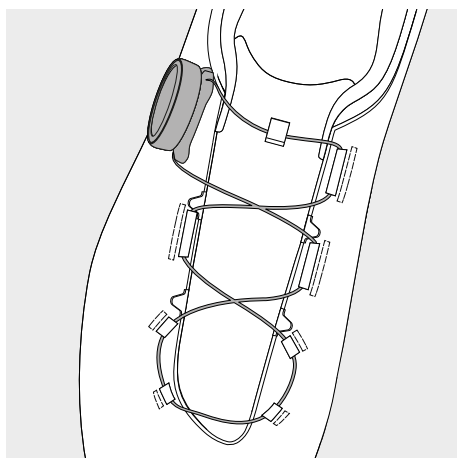

SINGLE BOA

Un sistema di chiusura veloce e sicuro, grazie alla chiusura BOA micro-regolabile che garantisce una vestibilità perfetta.

Un système de fermeture rapide et sûr, alimenté par une molette BOA micro-réglable pour un ajustement précis.

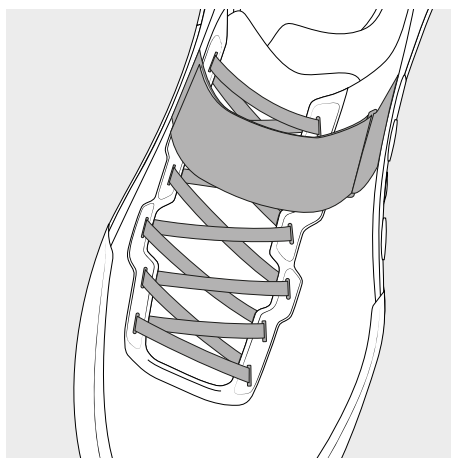

LACES + STRAP

Un sistema di allacciatura ergonomico che avvolge il piede e distribuisce la pressione in modo uniforme durante la pedalata.

Oltre a fissare i lacci, il Powerstrap sul collo del piede assicura una calzata stabile sostenendo l'arco plantare e bloccando il tallone.

Un modèle ergonomique à lacets qui enveloppe le pied et répartit la tension de manière homogène tout au long du coup de pédale. Le Powerstrap sur le cou-de-pied sécurise l'ajustement en stabilisant la voûte plantaire et en bloquant le talon en place tout en gardant les lacets sous contrôle.

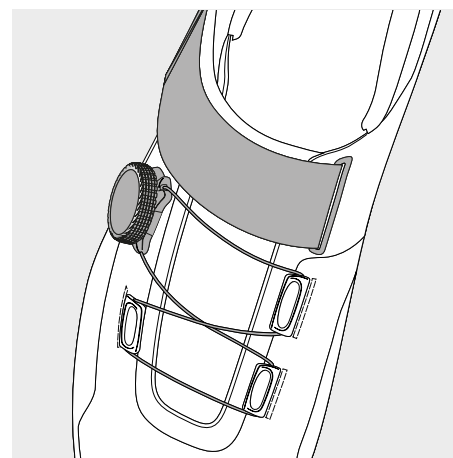

STRAP + BOA

Sistema di chiusura doppio con strap in velcro e BOA. Lo strap sul collo del piede garantisce la massima stabilità e un sostegno ottimale, mentre il BOA® Fit System nell'avampiede assicura una calzata di precisione micro-regolabile.

Système de fermeture double avec une sangle velcro et un cadran BOA. Sur le cou-de-pied, une sangle permet de contenir le pied de manière exceptionnelle, tout en offrant un système infaillible. En outre, un système BOA® Fit est situé à l'avant-pied, assurant un ajustement d'une précision micro-ajustable.

UPPER MATERIALS

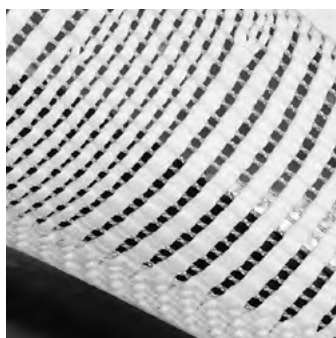

AEROWEAVE

Un tessuto avanzato che intreccia fibre di leggero nylon con filamenti di polimero termoplastico. Questa miscela di fili crea un materiale con una struttura aperta, simile a una rete, estremamente areata, ma altamente resistente e resiliente. Aeroweave è un materiale malleabile: si muove per cullare adeguatamente il piede, ma la sua tenacia assicura il supporto e il contenimento necessari per una scarpa da gara ad alte prestazioni.

Un tissu à l'avant garde qui tisse des fibres de nylon légères avec des filaments de polymère thermoplastique. Ce mélange de fils crée un matériau à structure ouverte, semblable à un filet, extrêmement aéré, mais très résistant et élastique. Aeroweave est un matériau malléable: il bouge pour bien préserver le pied, mais sa tenue assure le maintien et le confinement nécessaires à une chaussure de course performante.

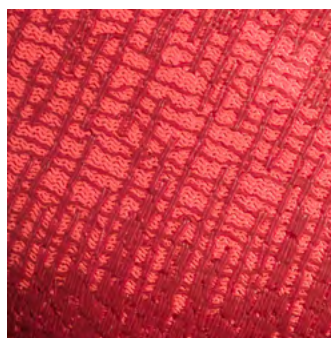

KNIT

Tomaia realizzata con macchine per maglieria elettroniche che uniscono con precisione i cicli di filato sugli aghi e invertono senza soluzione di continuità la direzione del filato del tessuto creando diversi schemi di cucitura. Questo processo permette di produrre zone funzionali distinte, assegnando prestazioni specifiche ad aree chiave, come le feritoie di ventilazione e le aperture a maglia per una maggiore traspirabilità.

Tiges faites avec des machines à tricoter électroniques qui associent avec précision les cycles de fil sur les aiguilles et inversent de manière transparente la direction du fil de tissu créant différents motifs de couture. Ce processus permet de produire des zones fonctionnelles distinctes, en attribuant des performances spécifiques aux zones clés, telles que les fentes de ventilation et les ouvertures en filet pour une plus grande respirabilité.



PU LAMINATED

Tomaia in materiale resiliente laminato in poliuretano combinato con un comodo tessuto a rete, in grado di garantire una maggiore robustezza, un sostegno del piede duraturo e una migliore traspirabilità dove è più necessario.

La partie supérieure est composée d'un matériau laminé en polyuréthane résistant combiné à une maille confortable, ce qui permet de réduire le rendement et d'offrir un soutien durable du pied et une ventilation améliorée là où c'est le plus nécessaire.

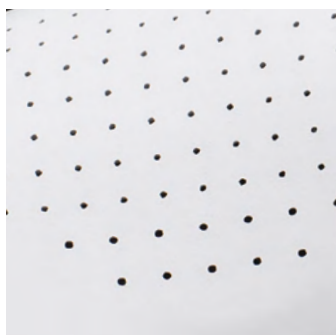

MICROTEX

Tomaia in materiale sintetico simile alla vera pelle: flessibile e allo stesso tempo resistente, per una calzata confortevole e durevole nel tempo.

Tige en matière synthétique ayant les capacités du cuir véritable: flexible et en même temps résistant, pour un ajustement confortable et durable.



RIPSTOP

Il Ripstop è un tessuto leggero e durevole con un'elevata resistenza a strappi e lacerazioni. La sua robustezza è dovuta all'inserimento di resistenti filati di rinforzo durante la tessitura, intrecciati a intervalli regolari.

Le Ripstop est un tissu tissé léger et résistant qui offre une haute résistance aux déchirures. Pendant le tissage, des fils de renfort plus résistants sont entrelacés à intervalles réguliers selon un motif hachuré pour réduire l'étalement des déchirures.

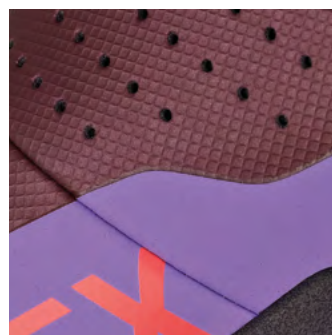

GORETEX

La membrana GORE-TEX traspirante e impermeabile mantiene i piedi asciutti in qualsiasi condizione atmosferica, consentendo al sudore evaporato di fuoriuscire facilmente. Le nostre scarpe invernali sono dotate inoltre di una morbida fodera in pile, per calore e comfort anche nelle giornate fredde.

La membrane GORE-TEX respirante et imperméable garde les pieds au sec par tous les temps tout en permettant à la vapeur de la transpiration de s'échapper facilement. Dans nos chaussures d'hiver, une doublure en polaire brossée douce apporte chaleur et confort lors des sorties froides.



3D AIR MESH

Una tomaia in mesh altamente traspirante e morbida che aiuta a mantenere i piedi asciutti e a migliorare la traspirabilità.

Une construction de l'empeigne en mesh, très respirante et souple, permet de garder les pieds au sec et d'améliorer la ventilation.

ROAD OUTSOLES

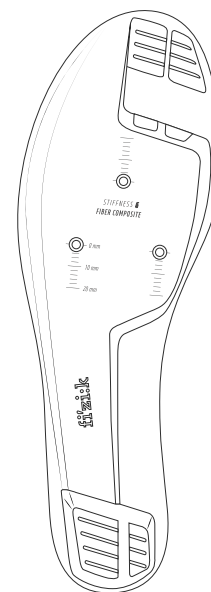
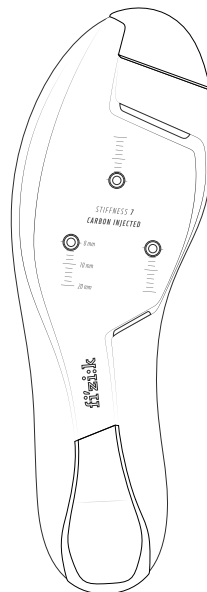
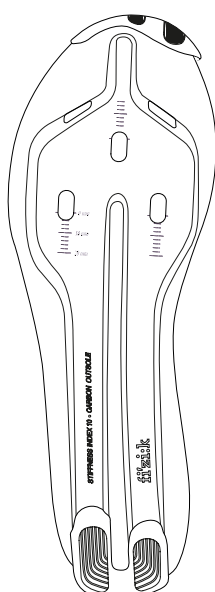
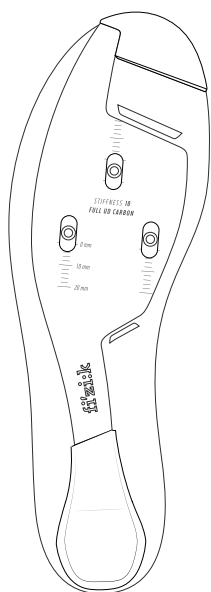

R2

INDICE DI RIGIDITÀ 10

Suola R2 in carbonio: posizionamento delle tacchette ottimizzato, alta rigidità e leggerezza finalizzate alla massima trasmissione di potenza.

INDICE DE RIGIDITÉ 10

Semelle carbone R2: positionnement optimisé des fixations des cale-pédales, rigidité et légèreté élevées pour une transmission de puissance maximale.

R3

INDICE DI RIGIDITÀ 10

La soluzione definitiva in termini di rigidità e leggerezza. Una suola in carbonio per una posizione ottimizzata delle tacchette e progettata per il massimo trasferimento di potenza.

INDICE DE RIGIDITÉ 10

L'ultime en matière de rigidité et de légèreté. Une semelle extérieure en carbone pour un positionnement optimisé des cales et un transfert de puissance maximal.

R4

INDICE DI RIGIDITÀ 7

Suola R4 in carbonio iniettato: moderatamente rigida per trasferire la potenza in modo confortevole.

INDICE DE RIGIDITÉ 7

Semelle en carbone injecté R4: moyennement rigide pour transférer la puissance en tout confort.

R5

INDICE DI RIGIDITÀ 6

Suola R5 in nylon e composito: bilancia comfort ed efficienza nella pedalata.

INDICE DE RIGIDITÉ 6

Semelle en nylon et composite R5: équilibre confort et efficacité lors du pédalage.

OFF-ROAD OUTSOLES

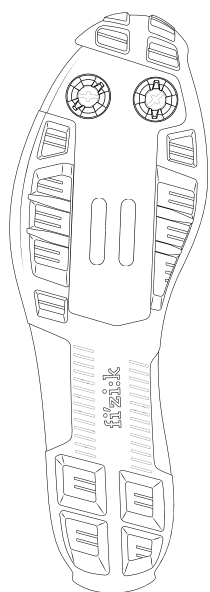

X1

INDICE DI RIGIDITÀ 10

Suola UD in carbonio, un'interfaccia con rigidità per la competizione, con durevole battistrada in TPU. Utilizzo indicato: Cross-Country, Ciclocross.

INDICE DE RIGIDITÉ 10

Semelle en carbone UD, une interface avec rigidité pour la compétition, avec semelle externe en TPU durable. Utilisation indiquée : VTT, Cyclocross.

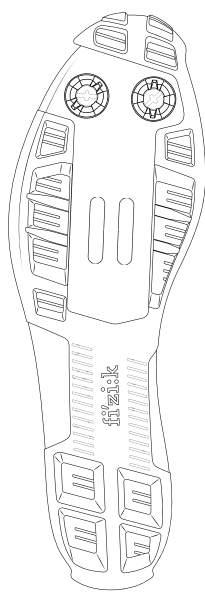

X3

INDICE DI RIGIDITÀ 8

Materiale in fibra composita per garantire elevata rigidità e un efficiente trasferimento di potenza, con una suola in gomma per il comfort. Utilizzo indicato: XC, CX, Gravel.

INDICE DE RIGIDITÉ 8

Fibre composite pour une haute rigidité et un transfert de puissance efficace avec une semelle extérieure en caoutchouc pour le confort. Utilisation indiquée : XC, CX, Gravel.

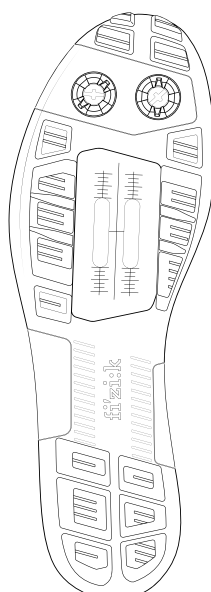

X5

INDICE DI RIGIDITÀ 5

Nylon rinforzato con un durevole battistrada in TPU. Utilizzo indicato: Cross Country, Ciclocross, Gravel Bike.

INDICE DE RIGIDITÉ 5

Nylon renforcé avec semelle externe en TPU durable. Utilisation indiquée : VTT, Cyclocross, Gravel.

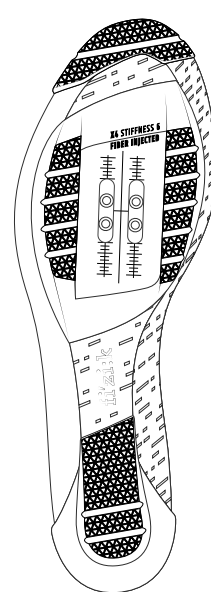

X4

INDICE DI RIGIDITÀ 6

Rigidità calibrata e gomma del battistrada adatta per le superfici miste. Utilizzo indicato: Gravel.

INDICE DE RIGIDITÉ 6

Rigidité calibrée et caoutchouc de semelle externe adapté aux surfaces mixtes. Utilisation appropriée : Gravel.

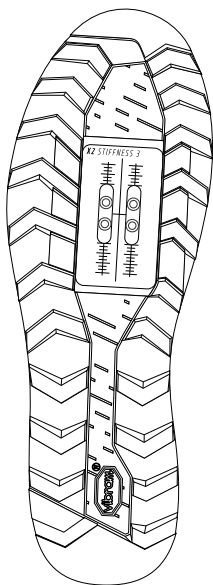

X2

INDICE DI RIGIDITÀ 3

Battistrada in Vibram per la trazione sui pedali e a piedi. Utilizzo indicato: Trail.

INDICE DE RIGIDITÉ 3

Semelle externe Vibram pour la traction en pédalant et pour les parties pédestres. Utilisation appropriée : Trail.

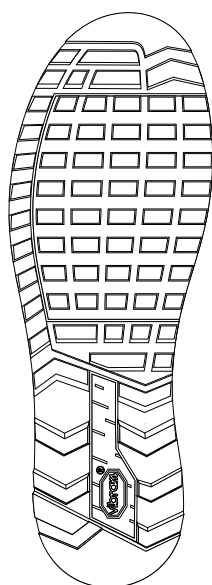

X2 FLAT

INDICE DI RIGIDITÀ 2

La miscela Vibram Megagrip combinata con il design del battistrada Fizik assicura un grip eccellente sui pedali flat e massima trazione anche durante la camminata. Utilizzo indicato: All-Mountain, Gravel, Bikepacking.

INDICE DE RIGIDITÉ 2

Le composé Vibram Megagrip combiné au design de la semelle fizik assure l'adhérence sur les pédales plates et une bonne traction en dehors du vélo. Utilisation indiquée : All-Mountain, Gravel, Bikepacking.

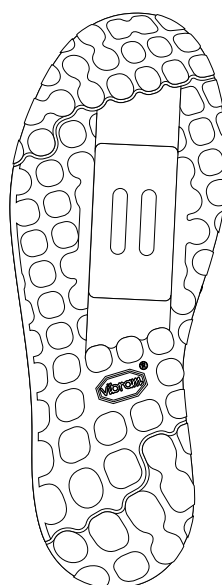

X6

INDICE DI RIGIDITÀ 5

La miscela e il design dei tasselli di Vibram® XS Trek EVO sono studiati per favorire il grip sui pedali e il massimo controllo della bicicletta per una guida gravity veloce e aggressiva. La guida per le tacchette estesa della versione clip-in consente un posizionamento delle tacchette più arretrato, per ottenere una migliore stabilità e un maggiore controllo in discesa grazie a una posizione del tallone più ribassata. Utilizzo indicato: DH-Enduro.

INDICE DE RIGIDITÉ 5

Le composé et le motif des crampons Vibram® XS Trek EVO sont conçus pour l'adhérence des pédales et le contrôle du vélo lors des sorties rapides et agressives en descente. Dotée d'une piste de crampons allongée, la version pour pédales automatiques vous permet de placer vos cales plus en arrière pour permettre de laisser tomber les talons dans les descentes, améliorant ainsi la stabilité et le contrôle. Utilisation indiquée : DH-Enduro.

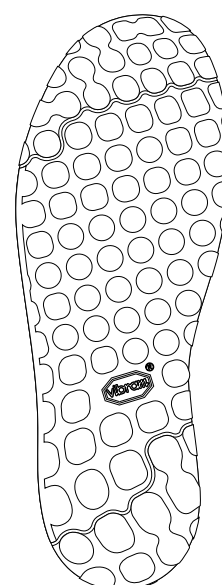

X6 FLAT

INDICE DI RIGIDITÀ 2

La miscela Vibram Megagrip e il design dei tasselli sono studiati per favorire il grip sui pedali e il massimo controllo della bicicletta per una guida gravity veloce e aggressiva. Utilizzo indicato: DH-Enduro.

INDICE DE RIGIDITÉ 2

Le composé Vibram Megagrip et le motif des crampons sont conçus pour assurer l'adhérence des pédales et le contrôle du vélo lors des sorties rapides et agressives en descente. Utilisation indiquée : DH-Enduro.

ROAD AND TRIATHLON SHOES







VENTO INFINITO KNIT CARBON 2 è una performante scarpa stradistica da competizione sviluppata con una nuova ed evoluta tomaia con struttura a maglia, per una maggiore traspirabilità.

VENTO INFINITO KNIT CARBON 2 est une chaussure de cyclisme de course sur route haute performance conçue avec une nouvelle tige tissu maille "knit" pour une meilleure respirabilité.

VENTO INFINITO KNIT CARBON 2

Intended use: ROAD RACING

Weight: 225g

Infinito: controllo ottimizzato del volume nell'area dell'avampiede

Volume Control: regolazione indipendente sul collo del piede e sull'avampiede

Tomaia Knitted: costruzione superventilata, con un supporto in TPU termosaldato

Suola R2 in fibra di carbonio: posizionamento ottimizzato delle tacchette, elevata rigidità e leggerezza ottimizzate per il trasferimento della potenza

Infinito : contrôle précis du volume de la zone de l'avant-pied

Volume Control : ajustement indépendant de l'ajustement pour le cou-de-pied et l'avant-pied

Tige tissu maille knit : construction extrêmement ventilée avec fil TPU thermofusible de soutien

Semelle externe en fibre de carbone R2 : positionnement optimisé des fixation des cales, rigidité et légèreté élevées pour un transfert de puissance maximal



ARTICLE	EAN	MODEL	COLOR	SIZE	OUTSOLE	CLOSURE	UPPER	SRP (€)
VER2IKR1C1010	Various	Vento Infinito Knit	Black/Black	36-48*	Full Carbon	2x BOA Li2 B dials	Knitted	380
VER2IKR1C9610	Various	Carbon 2	Coral/Black		Unidirectional			380

Tutti i modelli sono disponibili nelle taglie piene | Tous les modèles sont disponibles en tailles pleines

(*) Modello disponibile anche nelle taglie: **42½, 43½, 44½** | Egalement disponible dans les tailles: **42½, 43½, 44½**



VENTO INFINITO CARBON 2 è la versione più aggiornata della nostra leggendaria scarpa stradistica da competizione, sviluppata e scelta assieme ai migliori atleti del ciclismo professionistico.

VENTO INFINITO CARBON 2 est le dernier degré d'extrême perfection de notre légendaire chaussure de cyclisme de course sur route haute performance, développée avec et choisie par des athlètes de premier plan du peloton professionnel.

VENTO INFINITO CARBON 2

Intended use: ROAD RACING

Weight: 227g

Infinito: controllo ottimizzato del volume nell'area dell'avampiede
 Volume Control: regolazione indipendente sul collo del piede e sull'avampiede
 Tomaia in Microtex: morbida ma resistente e durevole, per una calzata comoda e durevole
 Suola R2 in fibra di carbonio: posizionamento ottimizzato delle tacchette, elevata rigidità e leggerezza ottimizzate per il trasferimento della potenza

Infinito : contrôle précis du volume de la zone de l'avant-pied
 Volume Control : ajustement indépendant de l'ajustement pour le cou de pied et l'avant-pied
 Tige Microtex : souple mais solide et durable pour un ajustement confortable et précis
 Semelle externe en fibre de carbone R2 : positionnement optimisé des fixation des cales pour un transfert de puissance maximal



ARTICLE	EAN	MODEL	COLOR	SIZE	OUTSOLE	CLOSURE	UPPER	SRP (€)
VER2IXR1C1010	Various	Vento Infinito Carbon 2	Black/Black	36-48*	Full Carbon Unidirectional	2x BOA Li2 B dials	Microtex	380
VER2IXR1C2010	Various		White/Black					380
VER2IXR1C7096	Various		Grey/Coral**					380

Tutti i modelli sono disponibili nelle taglie piene | Tous les modèles sont disponibles en tailles pleines

(*) Modello disponibile anche nelle taglie: **42½, 43½, 44½** | Egalement disponible dans les tailles: **42½, 43½, 44½**

(**) Fino ad esaurimento scorte | Jusqu'à épuisement des stocks



VENTO POWERSTRAP AEROWEAVE. L'innovativa tomaia di seconda generazione Aeroweave rende Powerstrap Aeroweave una scarpa da corsa senza compromessi. La più leggera e traspirante della gamma, è costruita con una struttura a rete ad elevata resistenza abbinata alla nostra suola in carbonio più rigida.

VENTO POWERSTRAP AEROWEAVE. La tige innovante Aeroweave de deuxième génération fait de la Powerstrap Aeroweave une chaussure de course à part entière. La plus légère et la plus respirante de la gamme, construite avec une structure de filet à haute résistance associée à notre semelle extérieure en carbone la plus rigide.

VENTO POWERSTRAP AEROWEAVE CARBON

Intended use: ROAD RACING

Weight: 184g

Aeroweave: struttura a rete estremamente traspirante e ad alta tenacità

Powerstrap: chiusura a strappo progettata per una calzata avvolgente

Suola R3 in carbonio: posizionamento ottimizzato delle tacchette, rigidità e leggerezza per una massima trasmissione di potenza

Aeroweave : structure extrêmement respirante, en forme de filet à haute résistance

Powerstrap : fermeture velcro enrobant le pied, conçue pour un ajustement enveloppant

Semelle R3 en carbone : positionnement optimisé des cales, rigidité et légèreté ultimes pour un transfert de puissance maximal



ARTICLE	EAN	NEW	MODEL	COLOR	SIZE	OUTSOLE	CLOSURE	UPPER	SRP (€)
VER3PAR1C2020	Various	NEW	Vento Powerstrap	White/White	36-48*	Full Carbon	Powerstrap	Aeroweave	350
VER3PAR1C9631	Various	NEW	Aeroweave Carbon	Coral/Orange	36-48*				

Tutti i modelli sono disponibili nelle taglie piene | Tous les modèles sont disponibles en tailles pleines

(*) Modello disponibile anche nelle taglie: **42½, 43½, 44½** | Egalement disponible dans les tailles: **42½, 43½, 44½**



TEMPO DECOS è stata progettata per collocarsi nel punto dove si incontrano comfort e prestazioni, è una scarpa essenziale che unisce un singolo rotore BOA minimalistico sulla tomaia con una rigida suola in carbonio per andare lontano.

TEMPO DECOS est conçue pour représenter le compromis idéal confort/performance, c'est une chaussure réunissant tige très simple et une unique molette de serrage BOA avec une semelle rigide en carbone pour tenir la distance.

TEMPO DECOS CARBON

Intended use: ROAD RACING

Weight: 205g

Tomaia in rete laminata PU: aerazione migliorata, supporto dove questo è necessario
Suola R2 in fibra di carbonio: posizionamento ottimizzato delle tacchette, elevata rigidità e leggerezza ottimizzate per il trasferimento della potenza

Tige en maille laminée PU : ventilation améliorée avec soutien là où c'est le plus nécessaire
R2 Semelle en fibre de carbone : positionnement optimisé des fixation des cales pédales, rigidité élevée et légèreté optimisées pour le transfert de puissance



TEMPO DECOS CARBON WIDE

Calzata larga: fornisce più spazio sull'avampiede, sviluppando un volume maggiore e più spazio al metatarso

Fit large: offre plus d'espace sur l'avant-pied, développant un plus grand volume et plus d'espace dans le métatarsien



ARTICLE	EAN	MODEL	COLOR	SIZE	OUTSOLE	CLOSURE	UPPER	SRP (€)
TPR2BMR1C3610	Various		Aubergine					290
TPR2BMR1C1010	Various	Tempo Decos Carbon	Black/Black	36-48*	Full Carbon Unidirectional	Li2 BOA® Fit System	PU Laminate Over Mesh	290
TPR2BMR1C2020	Various		White/White					290
TPR2BMR1C9910	Various		Iridescent Blue					290
TPR2BMW1C2020	Various	Tempo Decos Wide	White/White	36-48*	Full Carbon Unidirectional	Li2 BOA® Fit System	PU Laminate Over Mesh	290

Tutti i modelli sono disponibili nelle taglie piene | Tous les modèles sont disponibles en tailles pleines

(*) Modello disponibile anche nelle taglie: **42½, 43½, 44½** | Egalement disponible dans les tailles: **42½, 43½, 44½**





VENTO OMNA è una scarpa da ciclismo su strada reattiva e sviluppata per i ciclisti agonisti che cercano caratteristiche e prestazioni pronte per la gara.

Réactive, la VENTO OMNA est une pure chaussure de cyclisme sur route, conçue pour les coureurs qui recherchent des caractéristiques et des performances adaptées à la compétition.

VENTO OMNA

Intended use: ROAD

Weight: 238g

Suola in nylon R5: posizionamento ottimizzato delle tacchette con un indice di rigidità moderato
Tomaia in PU: un materiale resistente e leggero che rende la scarpa confortevole e durevole al tempo stesso
Pronta per gareggiare: calzata performante, regolabile tramite una singola chiusura BOA® bidirezionale

Semelle extérieure en nylon R5 : Positionnement optimisé des crampons avec un indice de rigidité modéré
Tige en PU : Un revêtement résistant et léger qui rend la chaussure confortable tout en conservant sa durabilité
Prête pour la course : Un ajustement performant, réglable grâce à une molette BOA® bidirectionnelle unique



VENTO OMNA WIDE NEW

Calzata larga: fornisce più spazio sull'avampiede, sviluppando un volume maggiore e più spazio al metatarso

Fit large: offre plus d'espace sur l'avant-pied, développant un plus grand volume et plus d'espace dans le métatarsien



ARTICLE	EAN	NEW	MODEL	COLOR	SIZE	OUTSOLE	CLOSURE	UPPER	SRP (€)
VER5BPR1K1010	Various			Black/Black	36-48*				165
VER5BPR1K2010	Various			White/Black	36-48				165
VER5BPR1K3010	Various		Vento Omna	Red/Black	36-48	R5 nylon	1x BOA Li2 Dial C Fit System	PU	165
VER5BPR1K7510	Various			Metallic Gun Metal/Black	36-48				165
VER5BPR1K3A10	Various			Cherry/Black	36-48				165
VER5BPW1K2010	Various	NEW	Vento Omna Wide	White/Black	36-48	R5 nylon	1x BOA Li2 Dial C Fit System	PU	165

Tutti i modelli sono disponibili nelle taglie piene | Tous les modèles sont disponibles en tailles pleines

(*) Modello disponibile anche nelle taglie: **42½, 43½, 44½** | Egalement disponible dans les tailles: **42½, 43½, 44½**



TEMPO OVERCURVE R4, una scarpa da ciclismo su strada polivalente disegnata per adattarsi alle uscite individuali o a quelle di gruppo del fine settimana, per l'allenamento quotidiano o per sfruttarle in occasione di una granfondo.

TEMPO OVERCURVE R4, une chaussure de cyclisme sur route polyvalente conçue pour s'adapter aux sorties individuelles ou en groupe le week-end, pour un entraînement quotidien ou pour en profiter lors d'une épreuve cyclo-sportive.

TEMPO OVERCURVE R4

Intended use: ROAD

Weight: 230g

Overcurve: costruzione asimmetrica che si adegua ergonomicamente all'anatomia del piede
Tomaia in rete laminata in PU: aerazione migliorata, supporto dove questo è necessario
Suola R4 in carbonio iniettato: moderatamente rigida per un trasferimento di potenza ottimale nel rispetto del comfort

Overcurve : construction asymétrique qui s'adapte ergonomiquement à l'anatomie du pied
Tige en mesh laminé PU : aération améliorée, avec un support là où cela est nécessaire
R4 Semelle en carbone injecté : moyennement rigide pour un transfert de puissance optimal tout en respectant le confort



TEMPO OVERCURVE R4 WIDE

Calzata larga: fornisce più spazio sull'avampiede, sviluppando un volume maggiore e più spazio al metatarso

Fit large: offre plus d'espace sur l'avant-pied, développant un plus grand volume et plus d'espace dans le métatarsien



ARTICLE	EAN	MODEL	COLOR	SIZE	OUTSOLE	CLOSURE	UPPER	SRP (€)
TPR4OXR1K1010	Various	Tempo Overcurve R4	Black/Black	36-48	Carbon Injected Nylon	1x BOA IP1-B dial	Pu Laminated Mesh	219
TPR4OXR1K2010	Various		White/Black					219
TPR4OXR1K4210	Various		Navy/Black					219
TPR4OIR1K8310	Various		Copper/Black Iridescent					219
TPR4OIR1K8410	Various		Beetle/Black Iridescent					219
TPR4OXW1K1010	Various	Tempo Overcurve R4 Wide	Black/Black	36-48	Carbon Injected Nylon	1x BOA IP1-B dial	Pu Laminated Mesh	219



TEMPO OVERCURVE R5 è una scarpa da ciclismo con calzata veloce che si adatta a ogni ciclista ed ogni tipo di uscita.

TEMPO OVERCURVE R5 est une chaussure de cyclisme avec un ajustement rapide qui s'adapte à chaque cycliste et à chaque style de pratique.

TEMPO OVERCURVE R5

Intended use: ROAD

Weight: 246g

Overcurve: costruzione asimmetrica che si adegua ergonomicamente all'anatomia del piede
Tomaia in Microtex: morbida ma resistente e duratura per una calzata confortevole e durevole nel tempo
Suola R5 in nylon e composito: permette di bilanciare comfort ed efficienza nella pedalata

Overcurve : construction asymétrique qui s'adapte de manière ergonomique à l'anatomie du pied
Empeigne en Microtex : douce mais résistante et durable pour un ajustement confortable et durable
Semelle en nylon et composite R5 : permet d'équilibrer confort et efficacité de pédalage



ARTICLE	EAN	MODEL	COLOR	SIZE	OUTSOLE	CLOSURE	UPPER	SRP (€)
TPR50CMI21010	Various	Tempo Overcurve R5	Black/Black**	36-48*				119
TPR50CMI22010	Various		White/Black**	36-48	Carbon			119
TPR50CMI21092	Various		Black/Pink Fluo**	36-42	Reinforced	1x BOA IP1-B dial + front Velcro	Microtex	119
TPR50CMI21090	Various		Black/Yellow Fluo**	38-48	Nylon			119
TPR50CMI27510	Various		Metallic Gun Metal/Black**	36-48				119

Tutti i modelli sono disponibili nelle taglie piene | Tous les modèles sont disponibles en tailles pleines

(*) Modello disponibile anche nelle taglie: **42½, 43½, 44½** | Egalement disponible dans les tailles: **42½, 43½, 44½**

(**) Fino ad esaurimento scorte | Jusqu'à épuisement des stocks



TEMPO POWERSTRAP R5 è una versatile scarpa da ciclismo su strada con un'innovativa chiusura Velcro disegnata per una calzata avvolgente.

TEMPO POWERSTRAP R5 est une chaussure de cyclisme sur route polyvalente avec une fermeture Velcro innovante conçue pour un ajustement parfait.

TEMPO POWERSTRAP R5

Intended use: ROAD

Weight: 255g

Powerstrap: chiusura con Velcro che avvolge il piede
Disegnata per una calzata avvolgente
Suola R5 in nylon e composito: permette di bilanciare comfort ed efficienza nella pedalata

Powerstrap : fermeture velcro qui enveloppe le pied.
Conçu pour un ajustement enveloppant
R5 Semelle en nylon et composite : permet d'équilibrer confort et efficacité lors du pédalage



ARTICLE	EAN	MODEL	COLOR	SIZE	OUTSOLE	CLOSURE	UPPER	SRP (€)
TPR5PSPU21010	Various	Tempo Powerstrap R5	Black/Black	36-48	Carbon Reinforced Nylon	Foot-wrapping Velcro	PU	139
TPR5PSPU22010	Various		White/Black					139
TPR5PSRE17410	Various		Reflective Grey/Black					149



TEMPO ARTICA R5 GTX è la nostra scarpa invernale specifica per il ciclismo su strada. La fodera in pile garantisce calore e isolamento, mentre l'avanzata membrana GORE-TEX offre traspirabilità e impermeabilità.

La TEMPO ARTICA R5 GTX est notre chaussure d'hiver spécifique à la route, isolée avec une doublure molletonnée pour plus de chaleur, respirante et imperméable grâce à une membrane GORE-TEX avancée.

TEMPO ARTICA R5 GTX

Intended use: ROAD

Weight: 319g

Membrana Gore-Tex Koala: isolata, impermeabile e traspirante, la membrana Koala di GORE-TEX ti mantiene caldo e asciutto durante le rigide giornate invernali

Fodera in pile: la morbida fodera in pile spazzolato aggiunge isolamento e comfort alle tue uscite anche nei giorni più freddi

Comfort per tutto il giorno: vestibilità generosa e regolazioni facili grazie al pratico BOA® Fit System a rotella singola e allo strap in velcro

Membrane Gore-Tex Koala : isolante, imperméable et respirante, la membrane Koala de GORE-TEX vous garde au chaud et au sec dans les conditions de sortie hivernales les plus difficiles

Doublure molletonnée : La doublure douce en polaire brossée ajoute de l'isolation et du confort lors des sorties hivernales les plus froides

Confort tout au long de la journée : La coupe généreuse et les ajustements faciles sont fournis par un système d'ajustement pratique à cadran unique BOA® et une sangle sécurisée en velcro



ARTICLE	EAN	MODEL	COLOR	SIZE	OUTSOLE	CLOSURE	UPPER	SRP (€)
TPR5AGR1V1010	Various	Tempo Artica R5 GTX	Black/Black	40-48	R5 nylon	1x BOA L6 dial & ankle Velcro strap	High-density PU upper + Ripstop fabric	259
TPR5AGR1V2070	Various		White/Grey					259



TRANSIRO HYDRA AEROWAVE una scarpa racing da triathlon che combina un'innovativa tomaia Aeroweave di seconda generazione con una suola rigida in carbonio per una pedalata efficiente e transizioni più veloci e senza preoccupazioni.

TRANSIRO HYDRA AEROWAVE une pure chaussure de triathlon qui associe une tige Aeroweave innovante de deuxième génération avec une semelle extérieure rigide en carbone pour un pédalage efficace et des transitions plus rapides et sans souci.

TRANSIRO HYDRA AEROWEAVE CARBON

Intended use: TRIATHLON

Weight: 225g

Aeroweave: struttura a rete estremamente traspirante e robusta

Strap in velcro sul collo del piede per transizioni rapide

Suola R2: interamente in carbonio - indice di rigidità 10

Aeroweave : structure en forme de maille extrêmement respirante et à haute ténacité.

Bande velcro sur le cou-de-pied pour une transition rapide

Semelle extérieure R2 : entièrement en carbone, indice de rigidité 10



ARTICLE	EAN	MODEL	COLOR	SIZE	OUTSOLE	CLOSURE	UPPER	SRP (€)
TRR2PAR1K2080	Various	Transiro Hydra Aeroweave Carbon	White/Silver	36-48*	Full carbon unidirectional	Instep velcro strap	Aeroweave	290
TRR2PAR1K20RB	Various		White/Red-Blue					290

Tutti i modelli sono disponibili nelle taglie piene | Tous les modèles sont disponibles en tailles pleines

(*) Modello disponibile anche nelle taglie: **42½, 43½, 44½** | Egalement disponible dans les tailles: **42½, 43½, 44½**



TRANSIRO HYDRA una scarpa da triathlon progettata per facilitare le transizioni, costruita con una tomaia traspirante e una suola in nylon moderatamente rigida che combina comfort ed efficienza di pedalata.

TRANSIRO HYDRA une chaussure de triathlon conçue pour faciliter les transitions, construite avec une tige respirante et une semelle extérieure en nylon modérément rigide qui associe confort et efficacité de pédalage.

TRANSIRO HYDRA

Intended use: TRIATHLON

Weight: 233g

3D Air mesh: tomaia estremamente traspirante e leggera
Strap in velcro sul collo del piede per transizioni rapide
Nuova suola in nylon R5 - indice di rigidità 6

Maille 3D Air : tige extrêmement respirante et légère
Bande velcro sur le cou-de-pied pour une transition rapide
Nouvelle semelle extérieure en nylon R5 - indice de rigidité 6



ARTICLE	EAN	MODEL	COLOR	SIZE	OUTSOLE	CLOSURE	UPPER	SRP (€)
TRR5PMR1K2010	Various	Transiro Hydra	White/Black	36-48	R5 nylon	Instep velcro strap	3D Air mesh	149
TRR5PMR1K20MR	Various		White/Metallic Red					149
TRR5PMR1K20MB	Various		White/Metallic Blue					149

OFF-ROAD SHOES







VENTO FEROX è una scarpa progettata per il fuoristrada agonistico, il cross-country e il gravel, unisce una suola in carbonio pronta alla competizione con una tomaia costruita in modo traspirante, leggera e anche durevole e resistente.

VENTO FEROX est une chaussure conçue pour les compétition tout-terrain le cross country et le gravel, réunissant une semelle carbone adaptée à la performance avec une partie supérieure respirante et légère mais durable et résistante.

VENTO FEROX CARBON

Intended use: CROSS-COUNTRY / GRAVEL RACING

Weight: 300g

Tomaia in rete laminata PU: leggera e traspirante con una costruzione a prova di strappo

Powerstrap & Boa Fit System: doppio sistema di chiusura dove il collo e la pianta del piede sono regolabili separatamente per una calzata personalizzata e sicura

Suola X1 in carbonio & Gomma: suola full carbon, elevata rigidità e leggerezza calibrate per il trasferimento di potenza e una trazione eccellente quando si è a piedi

Tige en maille laminée PU : légère et respirante donnant une construction indéchirable

Powerstrap & Boa Fit System : système de double fermeture où le cou-de-pied et le milieu du pied sont réglables séparément permettant un ajustement personnalisé et sécurisé

Semelle extérieure en carbone et caoutchouc X1 : semelle entièrement en carbone, haute rigidité et légèreté pour un transfert de puissance et une excellente traction à pied



ARTICLE	EAN	MODEL	COLOR	SIZE	OUTSOLE	CLOSURE	UPPER	SRP (€)
VEX1WMR1C1010	Various	Vento	Black/Black	36-48	Full Carbon Unidirectional, Rubber Treads	Li2 BOA® Fit System + Velcro Strap	PU Laminated Mesh	299
VEX1WMR1C3820	Various	Ferox	Lilac/White					299



VENTO PROXY è una scarpa off-road sviluppata per ciclisti competitivi che cercano caratteristiche pensate per le gare e un efficiente trasferimento di potenza su strade sterrate.

La VENTO PROXY est une chaussure de course tout-terrain développée pour les coureurs qui recherchent des caractéristiques pour la compétition et un transfert de puissance efficace sur les routes non goudronnées.

VENTO
PROXY NEW

Intended use: XC, CX, GRAVEL

Weight: 325g

Tomaia in rete laminata in PU: leggera e traspirante con una costruzione antistrappo
Pratico sistema di chiusura singola BOA
Suola in fibra composita X3 e gomma: elevata rigidità per un efficiente trasferimento di potenza e comfort

Empeigne en PU laminé : légère et respirante dans une construction résistante à la déchirure
Système de fermeture BOA simple pratique
Semelle extérieure en composite X3 Fiber et caoutchouc : grande rigidité pour un transfert de puissance efficace et confortable



ARTICLE	EAN	NEW	MODEL	COLOR	SIZE	OUTSOLE	CLOSURE	UPPER	SRP (€)
VEX3BPR1V1010	Various	NEW		Black/Black	36-48*				229
VEX3BPR1V9635	Various	NEW	Vento Proxy	Coral/Purple	36-48*	X3 Fiber composite and rubber outsole	BOA Li2	PU Laminated Mesh	229
VEX3BPR1V2020	Various	NEW		White/White	36-48*				229

Tutti i modelli sono disponibili nelle taglie piene | Tous les modèles sont disponibles en tailles pleines

(*) Modello disponibile anche nelle taglie: **42½, 43½, 44½** | Egalement disponible dans les tailles: **42½, 43½, 44½**



TERRA ATLAS la nostra versatile e affidabile all-terrain, per il gravel su tutti i tipi di percorso, per il mountain biking e anche oltre.

TERRA ATLAS notre modèle tout-terrain polyvalent et fiable, pour le gravel, le VTT et bien plus encore.

TERRA ATLAS

Intended use: CROSS-COUNTRY / GRAVEL /
DOWN-COUNTRY

Weight: 355g

Per tutti i terreni e tutte le situazioni: si adattano a una vasta gamma di stili di guida, dall' all-mountain al cross country e al gravel.
Comfort per tutto il giorno: vestibilità generosa, con un pratico sistema di chiusura con singolo rotore BOA
Suola X5 in nylon e gomma: assicura efficienza di pedalata assieme a una trazione in fuoristrada affidabile e sicura

Le All-Terrain, All-Rounder : convient à un large éventail de styles de pratique, du tout terrain au crosscountry et à la rando Gravel : avec un système de fermeture Boa, simple et pratique
Semelle extérieure en nylon et caoutchouc X5 offre une efficacité de pédalage ainsi qu'une traction tout-terrain rassurant et sûre



LIMITED EDITION

LIMITED EDITION



ARTICLE	EAN	MODEL	COLOR	SIZE	OUTSOLE	CLOSURE	UPPER	SRP (€)
TEX5BPR1K7010	Various		Grey/Black					159
TEX5BPR1K1010	Various		Black/Black					159
TEX5BPR1K6110	Various	Terra Atlas	Army	36-48	Nylon, Rubber Treads	L6 BOA® Fit System	Tear Resistant High Density PU	159
TEX5BPR1K3710	Various		Pink Grape					159
TEX5BPR1K1033	Various		Black/Splash Purple					159
TEX5BPR1K5039	Various		Green/Splash Pink					159



VENTO OVERCURVE X3 è una scarpa da cross-country racing disegnata e creata per sfruttare al meglio le sue funzioni chiave: calzare perfettamente, proteggerti e trasferire efficientemente i watt mentre si è impegnati sui circuiti di gara.

VENTO OVERCURVE X3 est une chaussure de compétition VTT conçue et créée pour tirer le meilleur parti de ses fonctions clés: s'adapter parfaitement, se protéger et transférer efficacement les watts sur les course les plus éprouvantes.

VENTO OVERCURVE X3

Intended use: CROSS-COUNTRY

Weight: 299g

Overcurve: costruzione asimmetrica che si adatta ergonomicamente all'anatomia del piede
Tomaia in Microtex: morbida ma resistente e duratura, per una calzata confortevole e durevole nel tempo
Suola X3: una rigida interfaccia per la competizione in carbonio iniettato, con durevole battistrada in TPU

Overcurve : construction asymétrique qui s'adapte ergonomiquement à l'anatomie du pied
Tige Microtex : douce mais résistante et durable, pour un ajustement confortable et ferme
Semelle X3 : une interface rigide pour la compétition en carbone injecté, avec une semelle externe en TPU durable



ARTICLE	EAN	MODEL	COLOR	SIZE	OUTSOLE	CLOSURE	UPPER	SRP (€)
VEX3OCMI11010	Various	Vento	Black/Black**	36-48*	Carbon Injected Nylon, TPU Studs	1x BOA IP1-B dial	Microtex	229
VEX3OCMI12010	Various	Overcurve X3	White/Black**					229

Tutti i modelli sono disponibili nelle taglie piene | Tous les modèles sont disponibles en tailles pleines

(*) Modello disponibile anche nelle taglie: **42½, 43½, 44½** | Egalement disponible dans les tailles: **42½, 43½, 44½**

(**) Fino ad esaurimento scorte | Jusqu'à épuisement des stocks





TERRA POWERSTRAP X4 è una scarpa versatile e polivalente ideale per il gravel biking: è perfetta per quei rider che le loro avventure le cercano ben oltre i classici percorsi asfaltati.

TERRA POWERSTRAP X4 est une chaussure polyvalente idéale pour la pratique du gravel: elle est parfaite pour les cyclistes qui recherchent l'aventure bien au-delà des routes goudronnées.

TERRA
POWERSTRAP X4

Intended use: GRAVEL

Weight: 292g

Powerstrap: chiusura con avvolgimento del piede con Velcro progettata per una vestibilità avvolgente
Suola X4: rigidità calibrata e gomma del battistrada adatta per le superfici miste

Powerstrap : fermeture enveloppante du pied par velcro conçue pour un ajustement parfait
Semelle X4 : rigidité calibrée et caoutchouc de semelle externe adapté aux surfaces mixtes



ARTICLE	EAN	MODEL	COLOR	SIZE	OUTSOLE	CLOSURE	UPPER	SRP (€)
TEX4PPR1K8586	Various	Terra	Mud/Caramel	36-48	Fiber Reinforced Nylon,	Foot-wrapping	PU	159
TEX4PPR1K1010	Various	Powerstrap X4	Black/Black		Rubber Tread	Velcro		159



TERRA CLIMA X2 è una scarpa da all-mountain resistente alle intemperie e traspirante che non si tirerà indietro quando le condizioni di guida si faranno ostiche.

TERRA CLIMA X2 est une chaussure tout terrain résistante aux intempéries et respirante qui sera à hauteur de vos attentes dans les conditions les moins favorables et les plus extrêmes.

TERRA CLIMA X2

Intended use: ALL-MOUNTAIN

Weight: 414g

Clima: tomaia traspirante e a prova di intemperie
 Tessuto Ripstop: tessuto resistente allo strappo e alla lacerazione
 Ghetta integrata in maglia per impedire l'ingresso di detriti
 Suola X2: in gomma Vibram per la trazione sui pedali e a piedi

Clima : Tige respirante et résistante aux intempéries
 Tissu Ripstop : tissu résistant à l'abrasion et à la déchirure
 Chausson tricotée intégrée : empêche la poussière et la saleté d'entrer
 Semelle X2 : caoutchouc Vibram pour la traction sur les pédales et dans les parties pédestres



ARTICLE	EAN	MODEL	COLOR	SIZE	OUTSOLE	CLOSURE	UPPER	SRP (€)
TEX2CLTX11010	Various	Terra Clima X2	Black/Black**	36-48	Nylon Shank, EVA Midsole, Vibram Megagrip Tread	Instep Velcro + 1x BOA L6 dial	Ripstop Fabric with Waterproof/Breathable Membrane	250

(**) Fino ad esaurimento scorte | Jusqu'à épuisement des stocks



TERRA ERGOLACE X2 è una scarpa da mountain bike robusta, adattabile, con i lacci, fedele alle radici del fuoristrada: potrai affrontarci ogni tipo di terreno, andarci tranquillamente su e giù per i trail, in sella oppure a piedi.

TERRA ERGOLACE X2 est une chaussure VTT robuste, adaptable, à lacets, fidèle aux racines du vélo tout-terrain: vous pouvez affronter tout type de terrain, monter et descendre les sentiers, à vélo ou à pied.

TERRA
ERGOLACE X2

Intended use: TRAIL, GRAVEL, BIKE PACKING

Weight: 329g

Ergolace: chiusura a lacci ergonomica per una calzata anatomica

Tessuto Ripstop: tessuto resistente allo strappo e alla lacerazione

Suola X2 outsole: in gomma Vibram per la trazione sui pedali e a piedi

Ergolace : fermeture à laçage ergonomique pour un ajustement anatomique

Tissu Ripstop : tissu résistant à l'abrasion et à la déchirure

Semelle extérieure X2 : en caoutchouc Vibram pour une meilleure adhérence sur les pédales et dans les parties pédestres



Black/Black
Available also in FLAT VERSION



FLAT VERSION Weight: 303g



ARTICLE	EAN	MODEL	COLOR	SIZE	OUTSOLE	CLOSURE	UPPER	SRP (€)
TEX2ETR1K4610	Various		Teal Blue/Black					129
TEX2ETR1K5886	Various	Terra Ergolace X2	Olive/Caramel	36-48	Nylon Shank, EVA Midsole, Vibram Tread	Laces	Ripstop Fabric	129
TEX2ETR1K1010	Various		Black/Black					129
TEX2ETF1K1010	Various	Terra Ergolace X2 Flat	Black/Black	36-48	EVA Midsole, Vibram Megagrip Tread	Laces	Ripstop Fabric	129



GRAVITA TENSOR è una robusta e leggera scarpa da mountain bike con forma adatta per il gravity di tipo competitivo. Pronta per la gara.

GRAVITA TENSOR est une chaussure de VTT robuste, légère et ajustée Gravity, prête pour la compétition.

GRAVITA TENSOR

Intended use: DH, ENDURO

Weight: 410g

Suola Clip-in Gravita: mescola Vibram Megagrip e tassellatura sviluppata per l'aderenza con il pedale e il controllo della bici

Tensor: calzata precisa e aderenza sul piede per le prestazioni

Puntale corazzato in TPU stampato ad iniezione: protezione solida del piede durante le guide "sporche"
Tessuto Ripstop: tessuto resistente allo strappo e alla lacerazione

Semelle Clip-in Gravity : Composition Vibram Megagrip développée pour l'adhérence avec la pédale et le contrôle du vélo

Tensor : ajustement précis et adhérence au pied pour la performance

Bout renforcé en TPU moulé par injection : protection solide du pied lors de randos sur terrain boueux

Tissu Ripstop : tissu résistant à l'abrasion et à la déchirure



Available also in FLAT VERSION



FLAT VERSION Weight: 310g



ARTICLE	EAN	MODEL	COLOR	SIZE	OUTSOLE	CLOSURE	UPPER	SRP (€)
GRX6TTC1C1010	Various	Gravita Tensor	Black/Black	36-48	Nylon Shank, EVA Midsole, Vibram Xs Trek EVO Tread	Laces + Instep Velcro	Ripstop Fabric + TPU Reinforcements	179
GRX6TTF1C1010	Various	Gravita Tensor Flat	Black/Black	36-48	EVA Midsole, Vibram Megagrip Tread	Laces + Instep Velcro	Ripstop Fabric + TPU Reinforcements	179



GRAVITA VERSOR è una versatile e leggera scarpa con lacci da mountain bike ideale per chi usa i pedali flat nei suoi trail di downhill assistiti con la seggiovia.

GRAVITA VERSOR est une chaussure de vélo de montagne à lacets polyvalente et légère. Elle est idéale pour ceux qui utilisent des pédales plates dans les pistes de descente acces et lorsqu'il faut utiliser télésiège pour y accéder.

GRAVITA VERSOR

Intended use: DH, ENDURO

Weight: 355g

Suola Clip-In Gravita: mescola Vibram Megagrip e tassellatura sviluppata per l'aderenza con il pedale e il controllo della bici

Ergolace: chiusura a lacci ergonomica per una calzata anatomica

Tessuto Ripstop: tessuto resistente allo strappo e alla lacerazione

Semelle Clip-In Gravita : Composition Vibram Megagrip développée pour l'adhérence avec la pédale et le contrôle du vélo

Ergolace : fermeture à laçage ergonomique pour un ajustement anatomique

Tissu Ripstop : tissu résistant à l'abrasion et à la déchirure



Available also in FLAT VERSION



FLAT VERSION Weight: 270g



ARTICLE	EAN	MODEL	COLOR	SIZE	OUTSOLE	CLOSURE	UPPER	SRP (€)
GRX6VTC1K7085	Various	Gravita Versor	Grey/Mud	36-48	Nylon Shank, EVA Midsole, Vibram Xs Trek EVO Tread	Laces	Ripstop Fabric	139
GRX6VTF1K7085	Various	Gravita Versor Flat	Grey/Mud	36-48	EVA Midsole, Vibram Megagrip Tread	Laces	Ripstop Fabric	139



TERRA ERGOLACE GTX è progettata per essere adattabile, passando facilmente da strade gravel a singletrack e viceversa. Il supporto della calzata la rende una scelta ideale per avventure prolungate, dove il comfort è fondamentale giorno dopo giorno.

La TERRA ERGOLACE GTX a été conçue pour s'adapter, passant facilement des routes gravel aux singletrack et vice-versa. Le maintien de la chaussure en fait un choix idéal pour les longues aventures, où le confort jour après jour est essentiel.

TERRA

ERGOLACE X2 GTX NEW

Intended use: TRAIL, GRAVEL, BIKEPACKING

Weight: 389g

Membrana Gore-Tex Prism 3L: protezione impermeabile e traspirante a triplo strato
Pronta per ogni avventura: scelta ideale per lunghe avventure in cui il comfort prolungato, giorno dopo giorno, è fondamentale. Progettata per essere adattabile, passando facilmente da strade gravel a singletrack e viceversa

Ergolace: allacciatura ergonomica per una fit anatomico

Suola X2: Vibram XS Trek Evo per una trazione sia in sella sia a piedi

Membrane Gore-tex prism 3l : protection imperméable respirante à trois couches

Prêt pour toutes les aventures : le choix idéal pour les aventures prolongées où le confort jour après jour est essentiel. Conçue pour être adaptable, elle passe facilement des routes de gravel aux singletrack et vice-versa.

Ergolace : fermeture à lacets ergonomique pour un ajustement anatomique

Semelle extérieure X2 : vibram xs trek evo pour l'adhérence, sur et en dehors du vélo



ARTICLE	EAN	NEW	MODEL	COLOR	SIZE	OUTSOLE	CLOSURE	UPPER	SRP (€)
TEX2EGR1V1410	Various	NEW	Terra Ergolace X2 GTX	Ice Grey/Black	38-48	X2 outsole – nylon shank, EVA midsole and Vibram tread	Ergolace lace-up pattern	Ripstop fabric with GTX membrane	189
TEX2EGR1V1210	Various	NEW	Terra Ergolace X2 GTX	Anthracite/Black	38-49	X2 outsole – nylon shank, EVA midsole and Vibram tread	Ergolace lace-up pattern	Ripstop fabric with GTX membrane	189



TERRA ARTICA X5 GTX è la nostra scarpa da ciclismo invernale off-road. Isolata e dotata di una membrana GORETEX impermeabile e traspirante, è una scarpa versatile, affidabile e adatta a qualsiasi tipo di terreno. Ideale per gravel, mountain bike e avventure off-road.

La TERRA ARTICA X5 GTX est notre chaussure de cyclisme hivernal tout-terrain. À la fois isolante et équipée d'une membrane GORETEX respirante et imperméable, c'est une chaussure polyvalente qui est fiable pour les sorties tout-terrain, le gravel, le VTT et au-delà.

TERRA
ARTICA X5 GTX

Intended use: GRAVEL, MTB

Weight: 432g

Artica: scarpa invernale impermeabile, traspirante e isolata

Suola X5 in nylon e gomma: assicura efficienza di pedalata assieme a una trazione in fuoristrada affidabile e sicura

Artica : chaussure d'hiver imperméable, respirante et isolante

Semelle extérieure en nylon et caoutchouc X5 offre une efficacité de pédalage ainsi qu'une traction tout-terrain rassurant et sûre



ARTICLE	EAN	MODEL	COLOR	SIZE	OUTSOLE	CLOSURE	UPPER	SRP (€)
TER5AGR1V1010	Various	Terra Artica X5 GTX	Black/Black	40-48	X5 nylon outsole with rubber treads	1x BOA L6 dial & ankle Velcro strap	High-density PU upper + Ripstop fabric	259
TER5AGR1V3510	Various		Purple/Black					259

SOCKS

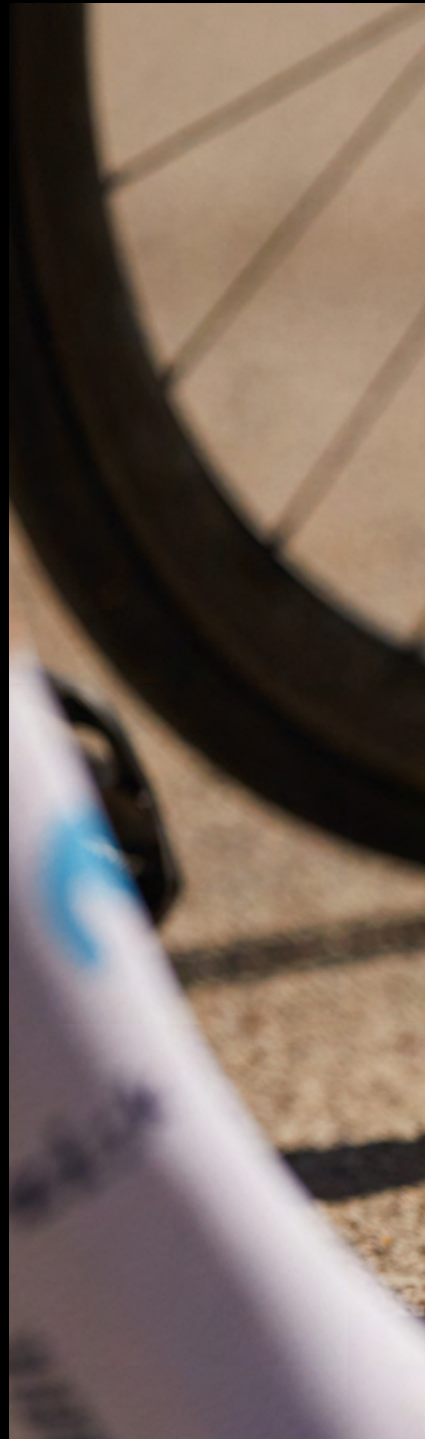



PERFORMANCE CYCLING SOCKS NEW

Intended use: ROAD

I nostri calzini da ciclismo ad alte prestazioni, realizzati in maglia con filato antibatterico Q-Skin® per un comfort traspirante e che assorbe l'umidità durante ogni ride.

- Filato Q-Skin®: altamente assorbente con proprietà antimicrobiche
- Zone in spugna nell'area delle tacchette: evita punti di pressione
- Costruzione sottile e leggera per migliorare la traspirabilità

Nos chaussettes performantes pour le cyclisme sur route, tricotées à partir du fil Q-Skin® anti-microbien pour un confort respirant et évacuant l'humidité à chaque sortie.

- Q-Skin® : haute capacité d'évacuation de l'humidité et propriétés anti-microbiennes
- Zones en tissu éponge sur les cales : évite les points de pression
- Construction fine et légère pour améliorer la respirabilité



TEAM EDITION CYCLING SOCKS NEW

Intended use: OFF-ROAD, ROAD RACING

Calzini da ciclismo colorati e con design deciso progettati per mantenere i piedi asciutti e in movimento, dando al team fizik comfort e stile.

- Filato Techno PE: altamente assorbente con proprietà antimicrobiche
- Zone in spugna nell'area delle tacchette e sull'arcata plantare: evita punti di pressione
- Tallone e punta più spessi per migliorare il comfort
- Costruzione a coste sulla gamba

Chaussettes de cyclisme colorées et audacieuses conçues pour garder les pieds au sec et rouler en représentant l'équipe Fizik dans le confort et le style.

- Fil Techno PE : haute capacité d'évacuation de l'humidité et propriétés anti-microbiennes
- Zones en tissu éponge sur les cales et le cou-de-pied : évite les points de pression
- Talon et avant pied plus épais pour améliorer le confort
- Construction en côtes sur la jambe



OFF-ROAD CYCLING SOCKS NEW

Intended use: OFF-ROAD

Calzini da ciclismo off-road comodi e resistenti, progettati per offrire una migliore traspirabilità e supporto duraturo durante grandi avventure lontano dall'asfalto.

- Filato Techno PE: altamente assorbente con proprietà antimicrobiche
- Zone in spugna nella zona delle tacchette e sull'arcata plantare: evita punti di pressione
- Tallone e punta più spessi per migliorare il comfort
- Costruzione a coste sulla gamba

Chaussettes de cyclisme tout-terrain confortables et résistantes, conçues pour offrir une meilleure respirabilité et un soutien durable lors des grandes aventures hors du bitume.

- Fil Techno PE : haute capacité d'évacuation de l'humidité et propriétés anti-microbiennes
- Zones en tissu éponge sur les cales et le cou-de-pied : évite les points de pression
- Talon et avant pied plus épais pour améliorer le confort
- Construction en côtes sur la jambe



ARTICLE	EAN	NEW	MODEL	COLOR	SIZE	MATERIAL	SRP (€)
FZKSOCKSRO1000	Various	NEW	Performance Cycling Socks	Black	S (35-39) M (40-43) L (44-47)	QSkin yarn	18,90
FZKSOCKSRO2000	Various	NEW		White			18,90
FZKSOCKSTE382000	Various	NEW	Team Edition Cycling Socks	Lilac-White	S (35-39) M (40-43) L (44-47)	Techno PE yarn	18,90
FZKSOCKSOF7010	Various	NEW	Off-Road Cycling Socks	Grey-Black	S (35-39) M (40-43) L (44-47)	Techno PE yarn	18,90

SHOES ACCESSORIES & PARTS

ARTICLE	EAN	MODEL	COLOR	SIZE	DESCRIPTION	SRP (€)
COVER						
FZTCW1000	-	Windproof Toe Cover	Black	XS (36-40) M (41-44) XL (45-48)	PU Cloth Main Fabric, Microfiber Toe Cap & Puller, Bottom PU Reinforced	25
FZSCWP109400	-	Waterproof Winter Overshoe	Black/ Reflective	S (36-39) M (40-43) L (44-46) XL (47-48)	WP and Windproof Upper, Rubberized Bottom for Better Grip, Reflective logo and Piping	59
KIT BOA SHOES						
120026410	8058364168937	LI2 Dial C KIT left and right	Black	-	1 boa left + 1 boa right compatible with Vento Omnia	37,50
120025720	8058364161334	LI2 Dial B KIT left and right	White	-	1 boa left + 1 boa right compatible with Stabilita Carbon	37,50
120026210	8058364161327	LI2 Dial B KIT left and right	Black	-	1 boa left + 1 boa right compatible with new Vento Infinito Carbon, Vento Infinito Knit Carbon and Stabilita Carbon, Vento Ferox Carbon, Tempo Decos Carbon	37,50
120025620	8058364161310	LI2 Dial A KIT left and right	White	-	1 boa left + 1 boa right compatible with Tempo Decos Carbon	37,50
120026010	8058364161341	IP1 KIT left and right	Black	-	1 boa left + 1 boa right compatible with all fi'zi:k R1M-BC, INFINITO R1, ARIA R3, OVERCURVE R4, OVERCURVE R5, TRIATHLON TRANSIRO R1 and R3 shoes, M3B (model from ss 2017 to 2018), M4B (model 2018), INFINITO X1 and VENTO OVERCURVE X3	25
120025920	8058364161358	IP1 KIT left and right	White/ Transparent	-	1 boa left + 1 boa right compatible with all fi'zi:k R1M-BC, INFINITO R1, ARIA R3, OVERCURVE R4, OVERCURVE R5, TRIATHLON TRANSIRO R1 and R3 shoes, M3B (model from ss 2017 to 2018), M4B (model 2018), INFINITO X1 and VENTO OVERCURVE X3	25
120026110	8058364161365	L6 KIT dial D left and right	Black	-	1 boa left + 1 boa right compatible with all fi'zi:k M4B (model 2017), TERRA X5 (model 2018) and M6B (model from 2017 to current), TERRA CLIMA X2, TERRA ARTICA X2, Terra Artica GTX and Tempo Artica GTX	19
120025510	8058364161303	LI2 Dial A KIT left and right	Black	-	1 boa left + 1 boa right compatible with Vento Ferox Carbon and Tempo Decos Carbon	37,50
120026310	8058364161389	L6 dial K KIT left and right / W CS1	Black	-	1 boa left + 1 boa right compatible with all Terra Atlas shoes	19
120025820	8058364161372	L6 KIT dial D left and right	White	-	1 boa left + 1 boa right compatible with Tempo Artica GTX	19
TOE STUDS KIT						
KTOESTUD1010	8058364147420	Toe Studs Kit	Black	-	Toe Studs Kit - Vento Ferox Carbon & Terra Atlas (pair)	7,99
KTOESTUD5B5B	8058364149127		Mint	-	Toe Studs Kit - Vento Ferox Carbon (pair)	7,99
KTOESTUD9090	8058364149134		Yellow Fluo	-	Toe Studs Kit - Vento Ferox Carbon (pair)	7,99
SHOES SPARE PARTS						
FZHSPR1C1000	-	Heel Skid Plate		S-L	Heel Skid Plate (pair) R1B shoes	15
FZHSPR3C1000	-		Black	S-M-L	Heel Skid Plate (pair) R3B shoes	13
KHPVER21C1000	-			S-L	Heel Skid Plate Vento R2	15

BARTAPES

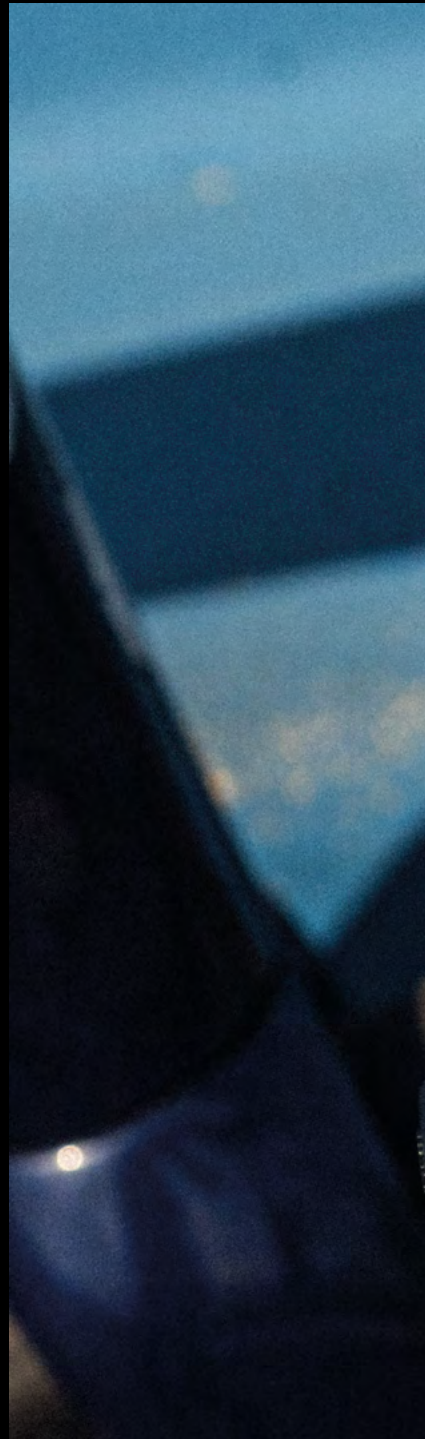



TOUCH



TACKY

2mm / 2.7mm / 3mm

Finitura che consegna una superficie aderente e antiscivolo per un grip superiore in ogni condizione.

Finition qui présente une surface confortable et antidérapante pour une adhérence supérieure dans toutes les conditions.



CLASSIC

2mm / 3mm

Una texture durevole e traforata come la pelle, con un look tradizionale e una superficie liscia che agevola le transizioni tra le diverse posizioni di guida.

Une texture durable similaire à du cuir perforé, avec une esthétique traditionnelle et une superficie lisse qui permet de glisser facilement par rapport à différentes positions de conduite.



SOFT

3mm

Una superficie dal look opaco e con finitura setosa, che assorbe l'umidità.

Une surface soyeuse, absorbant l'humidité, avec un aspect mat.

CONSTRUCTION

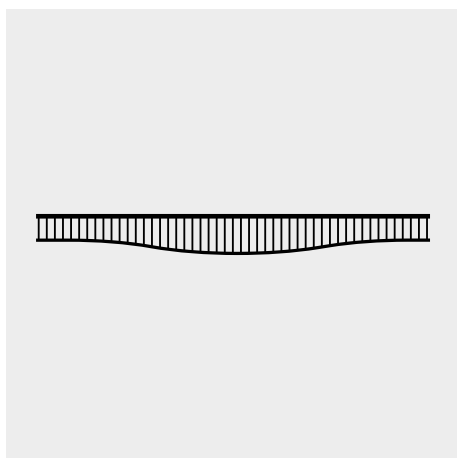

MICROTEX

2mm

La più sottile delle opzioni per una presa precisa e per il controllo.

La plus précise des options pour une adhérence et un contrôle précis.

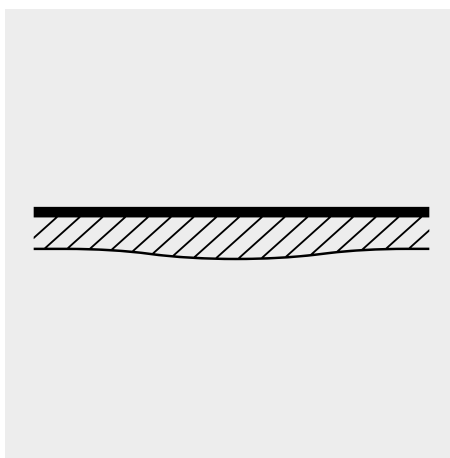

SOLOCUSH

2.7mm

La nostra costruzione più filante e ammortizzata, una piattaforma monostrato su cui fare affidamento durante le uscite più lunghe senza scendere a compromessi con il peso.

Notre fabrication la plus profilée et la plus rembourrée, une plate-forme monocouche sur laquelle vous pouvez compter sur vos plus longues sorties, sans jamais compromettre le poids.

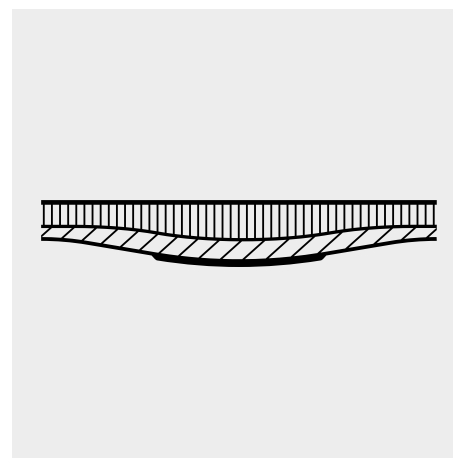

BONDCUSH

3mm

Una schiuma polimerica stratificata di media imbottitura che assorbe i microcolpi trasmessi dall'asfalto. Assieme allo strato esterno in Microtex, questo mix di materiali è la nostra opzione più valida per avere comfort, versatilità e durata.

Un rembourrage de mousse polymère stratifié qui absorbe les micro-coups transmis par l'asphalte. Avec la couche extérieure en Microtex, ce mélange de matériaux est notre meilleure option pour le confort, la polyvalence et la durabilité.

VENTO
**MICROTEX
 TACKY**

Intended use: ROAD RACING

Microtex è la più sottile delle opzioni per la maneggevolezza e il controllo. La finitura Tacky produce una superficie aderente e antiscivolo con una struttura in rilievo per una presa superiore in ogni condizione.

Le Microtex est l'option la plus fine pour une manipulation et un contrôle sans faille. La finition collante offre une surface antidérapante avec une texture en relief pour une adhérence optimale dans toutes les conditions.



ARTICLE	EAN	MODEL	COLOR	CONSTRUCTION	TOUCH	THICKNESS	SRP (€)
BT09000A00042	8021890466457	Vento Microtex Tacky	Black	Microtex	Tacky	2mm	40,90
BT09000A00044	8021890466464		White				40,90
BT09000A00012	8021890466440		Red				40,90
BT09000A00047	8021890466488		Orange Fluo				40,90
BT09000A00050	8021890466495		Pink Fluo				40,90
BT09000A00046	8021890466471		Yellow Fluo				40,90
BT09000A00051	8021890466501		Lilla Fluo				40,90
BT09000A00009	8021890466433		Celeste				40,90
BT15000A20042	8021890482693		Black/Celeste				43,90
BT15000A40042	8021890482716		Black/White				43,90
BT15000A50042	8021890482723		Black/Red				43,90
BT15000A60042	8021890482730		Black/Grey				43,90

VENTO

SOLOCUSH TACKY

Intended use: ROAD RACING

Solocush è la nostra costruzione più filante e morbida, con la sua generosa struttura monostrato su cui fare affidamento durante le uscite più lunghe ma senza mai scendere a compromessi con il peso. La finitura Tacky produce una superficie aderente e antiscivolo con una struttura in rilievo per una presa superiore in ogni condizione.

Solocush est notre fabrication la plus fine et la plus souple, avec sa généreuse structure monocouche sur laquelle vous pouvez compter sur vos sorties plus longues sans jamais compromettre le poids. La finition Tacky offre une surface confortable et anti-dérapante avec une surélevée pour une adhérence supérieure en toutes conditions.



ARTICLE	EAN	MODEL	COLOR	CONSTRUCTION	TOUCH	THICKNESS	SRP (€)
BT11000A00042	8021890466686		Black				43,90
BT11000A00044	8021890466693		White				43,90
BT11000A00055	8021890467034		Blue				43,90
BT11000A00025	8021890466679		Green				43,90
BT11000A00012	8021890466655		Red				43,90
BT11000A00011	8021890466648		Pink				43,90
BT11000A00014	8021890466662		Yellow				43,90
BT11000A00047	8021890466716	Vento Solocush Tacky	Orange Fluo	Solocush	Tacky	2,7mm	43,90
BT11000A00050	8021890466723		Pink Fluo				43,90
BT11000A00046	8021890466709		Yellow Fluo				43,90
BT11000A00051	8021890466730		Lilla Fluo				43,90
BT11000A00009	8021890466631		Celeste				43,90
BT11000A00057	8021890498885		Light Grey				43,90
BT11000A00058	8021890498892		Dark Grey				43,90
BT11000A00059	8021890498908		Mint Green				43,90

TEMPO

MICROTEX CLASSIC

Intended use: ROAD

Microtex è la più sottile delle opzioni per la maneggevolezza e il controllo. Classic Touch è una resistente texture traforata simile alla pelle, con un'estetica tradizionale e una superficie liscia che si maneggia facilmente nelle varie posizioni di guida.

Microtex est la plus fine des solutions pour la prise et le contrôle. Classic Touch est une texture perforée d'une résistance semblable au cuir, avec une esthétique traditionnelle et une surface lisse qui permet de changer aisément la position des mains.



TEMPO

MICROTEX BONDCUSH CLASSIC

Intended use: ROAD

Bondcush è una schiuma polimerica stratificata di media densità, che favorisce l'assorbimento dei colpi trasmessi dalla strada. Unità assieme allo strato esterno in Microtex questo mix di materiali diventa la nostra migliore opzione per avere quel comfort, quella versatilità e quella durezza perfette per avventurarsi su qualsiasi tipo di strada. Classic Touch è una resistente texture traforata simile alla pelle, con un'estetica tradizionale e una superficie liscia che si maneggia facilmente nelle varie posizioni di guida.

Bondcush est une mousse polymère stratifiée de densité moyenne, qui favorise l'absorption des coups transmis par la route. Associé à une couche externe en Microtex, ce mélange de matériaux devient notre meilleure solution procurant le confort, la polyvalence et la durabilité idéals pour pédaler sur tout type de route. Classic Touch est une texture perforée d'une résistance semblable au cuir, avec une esthétique traditionnelle et une surface lisse qui permet de changer aisément la position des mains.



ARTICLE	EAN	MODEL	COLOR	CONSTRUCTION	TOUCH	THICKNESS	SRP (€)
BT10000A00032	8021890466600	Tempo Microtex Classic	Black	Microtex	Classic	2mm	23,90
BT10000A00010	8021890466549		White				23,90
BT10000A00055	8021890467027		Blue				23,90
BT10000A00025	8021890466594		Green				23,90
BT10000A00012	8021890466563		Red				23,90
BT10000A00011	8021890466556		Pink				23,90
BT10000A00014	8021890466570		Yellow				23,90
BT10000A00045	8021890466617		Orange				23,90
BT10000A00018	8021890466587		Honey				23,90
BT10000A00006	8021890466525		Silver				23,90
BT10000A00009	8021890466532		Celeste				23,90
BT13000A00032	8021890466891		Tempo Microtex Bondcush Classic				Black
BT13000A00010	8021890466839	White		30,90			
BT13000A00018	8021890466877	Honey		30,90			

TEMPO

**MICROTEX BONDCUSH
SOFT**

Intended use: ROAD

Bondcush è una schiuma polimerica stratificata di media densità, che favorisce l'assorbimento dei colpi trasmessi dalla strada. Unita assieme allo strato esterno in Microtex questo mix di materiali diventa la nostra migliore opzione per avere quel comfort, quella versatilità e quella durevolezza perfette per avventurarsi su qualsiasi tipo di strada. Soft Touch è una superficie dall'aspetto opaco, con fattezze setose che assorbono l'umidità.

Bondcush est une mousse polymère stratifiée de densité moyenne, qui favorise l'absorption des coups transmis par la route. Associé la couche externe en Microtex, ce mélange de matériaux devient notre meilleure solution procurant le confort, la polyvalence et la durabilité idéal pour pédaler tout type de route. La finition Soft touch procure un toucher doux et une surface d'aspect mat et soyeuse absorbant l'humidité.



TEMPO

**MICROTEX BONDCUSH
TACKY - Les Classiques**

Intended use: ROAD

Bondcush è una schiuma polimerica stratificata di media densità, che favorisce l'assorbimento dei colpi trasmessi dalla strada. Unita assieme allo strato esterno in Microtex questo mix di materiali diventa la nostra migliore opzione per avere quel comfort, quella versatilità e quella durevolezza perfette per avventurarsi su qualsiasi tipo di strada. La finitura Tacky produce una superficie aderente e antiscivolo con una struttura in rilievo per una presa superiore in ogni condizione.

Bondcush est une mousse polymère stratifiée de densité moyenne, qui favorise l'absorption des coups transmis par la route. Associé la couche externe en Microtex, ce mélange de matériaux devient notre meilleure solution procurant le confort, la polyvalence et la durabilité idéal pour pédaler tout type de route. La finition Tacky offre une surface confortable et anti-dérapante avec une structure surélevée pour une grip parfait en toute circonstance.

Le Classiques
Limited Edition



ARTICLE	EAN	MODEL	COLOR	CONSTRUCTION	TOUCH	THICKNESS	SRP (€)
BT14000A00002	8021890466914	Tempo Microtex Bondcush Soft	Black	Microtex Bondcush	Soft	3mm	30,90
BT14000A00012	8021890466969	Tempo Microtex Bondcush Soft	Red	Microtex Bondcush	Soft	3mm	30,90
BT16000A00042	8021890497543	Tempo Microtex Bondcush Tacky	Le Classiques	Microtex Bondcush	Tacky	3mm	43,90

TERRA

MICROTEX BOND CUSH TACKY

Intended use: GRAVEL

Bondcush è una schiuma polimerica stratificata di media densità, che favorisce l'assorbimento dei colpi trasmessi dalla strada. Unita assieme allo strato esterno in Microtex questo mix di materiali diventa la nostra migliore opzione per avere quel comfort, quella versatilità e quella durezza perfette per avventurarsi su qualsiasi tipo di strada. Il supporto inferiore in gel ha una doppia funzione: rimpiazza il tradizionale nastro adesivo per una rimozione e una pulizia più facili in caso di sostituzione e assorbe i colpi della strada senza dare la sensazione di essere troppo gommoso. La finitura Tacky favorisce una presa sicura e antiscivolo garantendo un grip superiore in tutte le condizioni.

Bondcush est une mousse polymère stratifiée de densité moyenne, qui favorise l'absorption des coups transmis par la route. Associé la couche externe en Microtex, ce mélange de matériaux devient notre meilleure solution procurant le confort, la polyvalence et la durabilité idéal pour pédaler tout type de route. Un support en gel collant remplit deux fonction: il remplace le ruban adhésif pour un démontage facile du ruban pour un remplacement et amortit vibrations sans toutefois être trop mou. La finition Tacky offre une surface anti-dérapante pour un grip parfait en toute circonstance.



ARTICLE	EAN	MODEL	COLOR	CONSTRUCTION	TOUCH	THICKNESS	SRP (€)
BT12000A00002	8021890466747	Terra Microtex Bondcush Tacky	Black	Microtex Bondcush	Tacky	3mm	43,90
BT12000A00016	8021890466761		White				43,90
BT12000A00012	8021890466754		Red				43,90
BT12000A00052	8021890466778		Dark Blue				43,90
BT12000A00053	8021890466785		Green/Blue				43,90
BT12000A00054	8021890466792		Brown				43,90
BT12000A00057	8021890498915		Light Grey				43,90

VENTO

**MICROTEX TACKY 2mm
BOX 10 KITS (20 ROLLS)**

1 kit contiene:

- 2 rotoli di nastro Vento Microtex Tacky 2mm nero
- 2 strisce di nastro extra
- 2 tappi manubrio
- 2 nastri di finitura

1 kit contient :

- 2 rouleaux de ruban adhésif noir Vento Microtex Tacky 2mm
- 2 bandes de ruban adhésif supplémentaires
- 2 bouchons de cintre
- 2 rubans de finition



TEMPO

**BONDCUSH SOFT 3mm
BOX 10 KITS (20 ROLLS)**

1 kit contiene:

- 2 rotoli di nastro Tempo Bondcush 3mm Soft nero
- 2 strisce di nastro extra
- 2 tappi manubrio
- 2 nastri di finitura

1 kit contient :

- 2 rouleaux de ruban adhésif noir souple Tempo Bondcush 3mm
- 2 bandes de ruban adhésif supplémentaires
- 2 bouchons de cintre
- 2 rubans de finition



BAR GEL KIT

- 2 strisce di gel curve tagliate su misura
- 2 strisce di gel rettilinee tagliate su misura
- 2 strisce di chiusura superiori

- 2 pièces de gel cintrées ajustables à la dimension souhaitée
- 2 pièces de gel droites ajustables à la dimension souhaitée
- 2 bandes adhésives pour les extrémités



ARTICLE	EAN	MODEL	COLOR	CONSTRUCTION	TOUCH	THICKNESS	SRP (€)
FZKTAPE000000	8021890579638	Vento Microtex Tacky 10 Kits (20 rolls)	Black	Microtex	Tacky	2mm	-
FZKTAPE020000	8021890579652	Tempo Bondcush Soft 10 Kits (20 rolls)	Black	Microtex Bondcush	Soft	3mm	-
BG02000A10003	8021890580634	Bar Gel Kit	4 Pieces of Gel (2 curved + 2 straight) + 2 wrap strips				20



crankbrothers





CRANKBROTHERS



PEDALS

UNA RIVOLUZIONE IN TERMINI DI PERFORMANCE ED AFFIDABILITÀ

NUOVI MODELLI, TECNOLOGIE AVANZATE E COMPONENTI D'ALTA GAMMA SI COMBINANO NELLA NOSTRA LINEA DI PEDALI, LA PIÙ INNOVATIVA DI SEMPRE.

UNE RÉVOLUTION EN TERMES DE PERFORMANCE ET FIABILITÉ
DE NOUVEAUX MODÈLES, DES TECHNOLOGIES INNOVANTES ET DES
COMPOSANTS HAUT DE GAMME CARACTÉRISENT NOTRE LIGNE DE PÉDALES,
LE TOUT DANS UN NIVEAU DE FINITION JAMAIS ATTEINT.



COMPONENTI DI QUALITÀ SUPERIORE COMPOSANTS DE QUALITÉ PREMIUM

CUSCINETTI ENDURO® | ROULEMENT ENDURO®

SISTEMA DI CUSCINETTI ESTERNI PREMIUM

- Progettati in modo specifico per pedali (bassa velocità, alto valore di coppia)
- Materiali, lubrificante e guarnizioni di qualità premium
- Maggior resistenza alla corrosione
- Tolleranze maggiori per un fit più preciso

(*) In tutti i nuovi pedali prodotti verrà installato al posto dell'Enduro Bearing l'Enduro Max cartridge bearing, ancora più affidabile.



ROULEMENT EXTERNE PREMIUM

- Conçu spécifiquement pour les pédales (basse vitesse, couple élevé)
- Matériaux, roulements et graisse de qualité supérieure
- Résistance à la corrosion
- Tolérances supérieures pour un ajustement précis

(*) Pour toute la nouvelle production de pédales, le roulement à cartouche Enduro Max, encore plus fiable, sera monté à la place du roulement Enduro.

CUSCINETTI IGUS LL-GLIDE | ROULEMENT IGUS LL-GLIDE

SISTEMA DI CUSCINETTI INTERNO PREMIUM

- Sviluppato in esclusiva per Crankbrothers
- Una performance otto volte superiore dai test in laboratorio di igus
- Una performance fino a 74 volte migliore dai test condotti da Crankbrothers
- Ottime prestazioni anche in condizioni avverse



ROULEMENT INTERNE PREMIUM

- Développés en exclusivité pour Crankbrothers
- Une performance 8 fois supérieure selon les tests de laboratoire aigus
- Une performance 74 fois supérieure selon nos derniers tests en interne.
- Effectué dans les conditions les plus extrêmes

SISTEMA A DOPPIA GUARNIZIONE | DOUBLE SYSTÈME D'ÉTANCHÉITÉ

GUARNIZIONE INTERNA DOUBLE-LIP E GUARNIZIONE ESTERNA

- Impedisce l'entrata di sporco e acqua all'interno del pedale
- Test di laboratorio e su strada condotti in condizioni estreme
- Previene dalla corrosione dei pedali e ne aumenta la durata nel tempo

JOINT INTERNE DOUBLE-LIP ET JOINT EXTÉRIEUR

- Empêche l'eau et la boue de pénétrer à l'intérieur de la pédale
- Testé en laboratoire et sur le terrain dans les pires conditions
- Protège de la corrosion et prolonge la vie de la pédale



guarnizione interna double-lip
joint interne double-lip

guarnizione esterna
joint extérieur





CLIP-IN PEDALS MALLET DH



MALLET DH 11



MALLET DH RACE

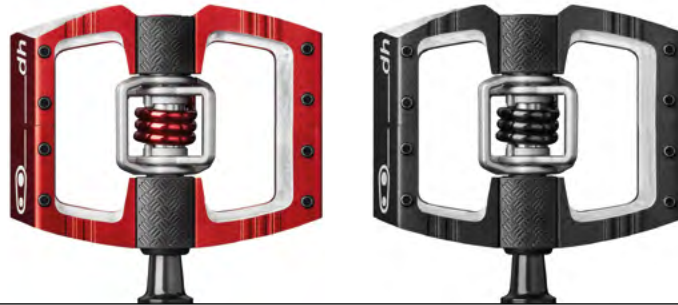

ARTICLE	UPC	MODEL	BODY COLOR	SPRING COLOR	WEIGHT*	WING MATERIAL	Q-FACTOR	PRICE (€)
16096	641300160966	mallet dh 11	black	gold	445g	titanium	57mm	350
16094	641300160942	mallet dh race	black	black	479g	cast steel	57mm	180
16095	641300160959		red	red				180

(*) Tutti i pesi sono intesi per coppia di pedali | Tous les poids indiqués sont par paire de pédales

CLIP-IN PEDALS
MALLET E

11 MALLET E 11



MALLET E



MALLET E LS
(LONG SPINDLE)



SPLATTER EDITION

ARTICLE	UPC	MODEL	BODY COLOR	SPRING COLOR	WEIGHT*	WING MATERIAL	Q-FACTOR	PRICE (€)
16093	641300160935	mallet e 11	black	gold	385g	titanium	52mm	350
15990	641300159908	mallet e	black	black	419g	cast steel	52mm	180
15991	641300159915		electric blue	blue				
16080	641300160805	mallet e ls	blue**	black	424g	cast steel	57mm	180
16247	641300162472		silver**	black				
16708	641300167088	mallet e ls	lime green/black**	black	424g	cast steel	57mm	180
16710	641300167101	splatter edition	blue/black**	black				

(*) Tutti i pesi sono intesi per coppia di pedali | Tous les poids indiqués sont par paire de pédales

(**) Fino ad esaurimento scorte | Jusqu'à épuisement des stocks

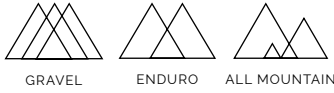

CLIP-IN PEDALS MALLET TRAIL

MALLET TRAIL

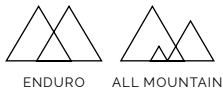

CLIP-IN PEDALS MALLET 3-2

3 MALLET 3



2 MALLET 2



ARTICLE	UPC	MODEL	BODY COLOR	SPRING COLOR	WEIGHT*	WING MATERIAL	Q-FACTOR	PRICE (€)
16759	641300167590	mallet trail	black	black				180
16760	641300167606		champagne	black	344g	cast steel	57mm	180
16761	641300167613		purple	black				180
15988	641300159885	mallet 3	raw/black	blue	499g	cast steel	52mm	150
15989	641300159892		raw/red**	red				
15987	641300159878	mallet 2	raw/green**	black	508g	stamped steel	52mm	100
15986	641300159861		raw/silver	black				

(*) Tutti i pesi sono intesi per coppia di pedali | Tous les poids indiqués sont par paire de pédales

(**) Fino ad esaurimento scorte | Jusqu'à épuisement des stocks

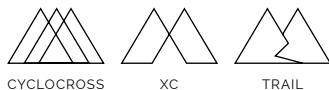

CYCLOCROSS

XC

TRAIL

CLIP-IN PEDALS

CANDY

11

CANDY 11



7

CANDY 7



3

CANDY 3



ARTICLE	UPC	MODEL	BODY COLOR	SPRING COLOR	WEIGHT*	WING MATERIAL	TRACTION PADS	PRICE (€)
15984	641300159847	candy 11	gold	gold	249g	titanium	integrated	500
16178	641300161789		black/electric blue	black				180
15981	641300159816	candy 7	black	black	320g	cast steel	integrated	180
15982	641300159823		red	red				180
16175	641300161758		black	black				150
16177	641300161772	candy 3	dark red**	red	340g	cast steel	included	150
16176	641300161765		slate blue	blue				150

(*) Tutti i pesi sono intesi per coppia di pedali | Tous les poids indiqués sont par paire de pédales

(**) Fino ad esaurimento scorte | Jusqu'à épuisement des stocks

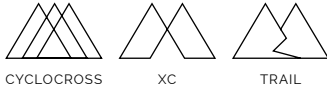

CLIP-IN PEDALS CANDY

2 CANDY 2



1 CANDY 1

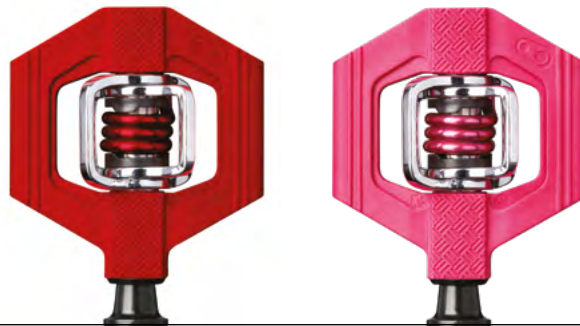

ARTICLE	UPC	MODEL	BODY COLOR	SPRING COLOR	WEIGHT*	WING MATERIAL	TRACTION PADS	PRICE (€)
16173	641300161734	candy 2	dark grey	black	355g	stamped steel	optional	100
16634	641300166340		red	black				100
16169	641300161697	candy 1	black	black	294g	stamped steel	not compatible	60
16171	641300161710		light blue	blue				60
16170	641300161703		red	red				60
16172	641300161727		pink	pink				60

(*) Tutti i pesi sono intesi per coppia di pedali | Tous les poids indiqués sont par paire de pédales



CYCLOCROSS

XC

TRAIL

CLIP-IN PEDALS EGGBEATER

11 EGGBEATER 11



3 EGGBEATER 3



2 EGGBEATER 2



1 EGGBEATER 1



ARTICLE	UPC	MODEL	BODY COLOR	SPRING COLOR	WEIGHT*	WING MATERIAL	TRACTION PADS	PRICE (€)
11495	641300114952	eggbeater 11	gold	gold	179g	titanium	1mm included	500
16098	641300160980	eggbeater 3	light blue	electric blue	280g	cast steel	1mm included	150
15319	641300153197		red	red				150
15859	641300158598		black	black				150
15317	641300153173	eggbeater 2	black	black	285g	stamped steel	optional	100
15985	641300159854		black	green				100
14792	641300147929	eggbeater 1	silver	red	290g	stamped steel	not compatible	60
14791	641300147912		silver	black				60

(*) Tutti i pesi sono intesi per coppia di pedali | Tous les poids indiqués sont par paire de pédales



HYBRID PEDALS DOUBLE SHOT

3

DOUBLE SHOT 3

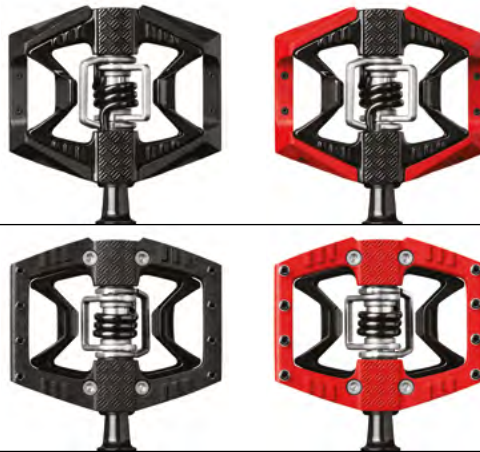

CLIP-IN SIDE

FLAT SIDE

2

DOUBLE SHOT 2



CLIP-IN SIDE

FLAT SIDE

1

DOUBLE SHOT 1

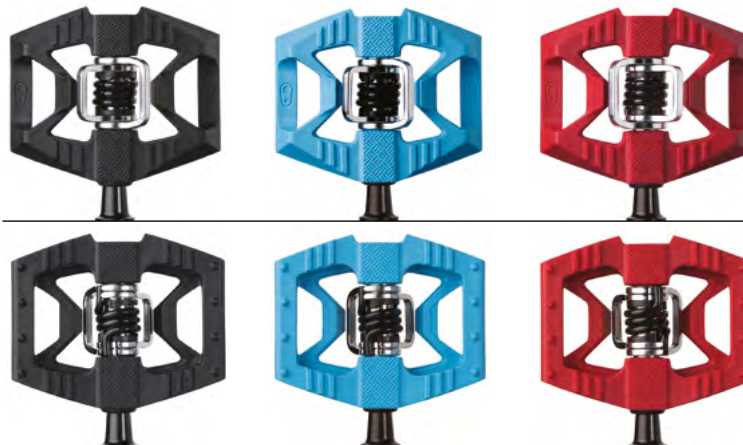

CLIP-IN SIDE

FLAT SIDE

ARTICLE	UPC	MODEL	BODY COLOR	SPRING COLOR	WEIGHT*	BODY MATERIAL	PINS	Q-FACTOR	PRICE (€)
16111	641300161116	double shot 3	black	black	403g	aluminum	8 adjustable	57mm	150
16110	641300161109		red/black	black					150
16006	641300160065	double shot 2	black/silver	blue	395g	aluminum	8 molded	57mm	100
16007	641300160072		orange/black	orange					100
16077	641300160775		blue/black	black					100
16179	641300161796	double shot 1	black	black	331g	composite	8 molded	57mm	60
16181	641300161819		blue	black					60
16180	641300161802		red	black					60

(*) Tutti i pesi sono intesi per coppia di pedali | Tous les poids indiqués sont par paire de pédales



FLAT PEDALS

FIND YOUR PERFECT SIZE

ABBIAMO ANALIZZATO I PROFILI DELLE SUOLE DELLE MIGLIORI MARCHE DI CALZATURE DA MOUNTAIN BIKE E ABBIAMO INDIVIDUATO DUE SUPERFICI DISTINTE PER OTTIMIZZARE L'INTERFACCIA SCARPA/PEDALE PER L'INTERA GAMMA DI MISURE DELLE CALZATURE.

NOUS AVONS PROCÉDÉ À UNE ÉTUDE DES PROFILS DES SEMELLES DES MEILLEURES MARQUES DE CHAUSSURES DE VTT ET À LA SUITE DE ÇA, MIS AU POINT DEUX SURFACES DISTINCTES POUR OPTIMISER L'INTERFACE CHAUSSURE/PÉDALE POUR TOUTE LA GAMME DE TAILLES DE CHAUSSURES.

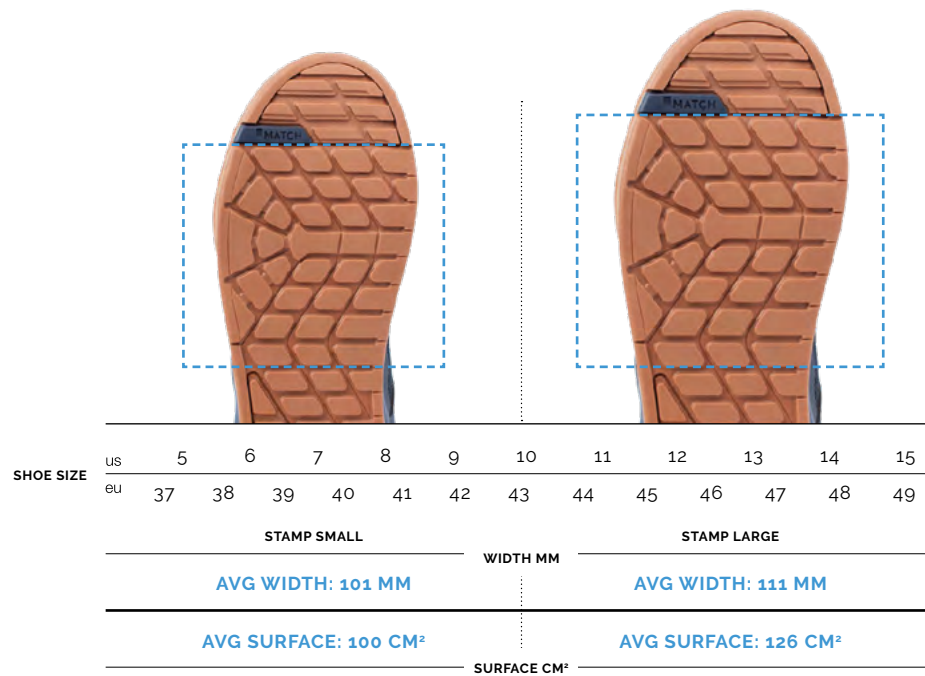

SUPERFICIE OTTIMALE | SURFACE OPTIMALE

- Basato sull'analisi delle misure delle scarpe e della superficie delle soles
 - Due misure, ciascuna con una superficie ottimizzata in base alla taglia
 - Aumento del grip, del supporto e del contatto con il pedale
 - Riduce il peso e l'area d'impatto con le rocce
-
- Basée sur l'analyse des dimensions des chaussures et la surface des semelles
 - Deux différentes tailles avec des surfaces optimales pour les diverses gammes de tailles de chaussures
 - Optimise l'adhérence, le support et l'interface avec le pédale
 - Réduit considérablement le poids et prévient des chocs avec le terrain

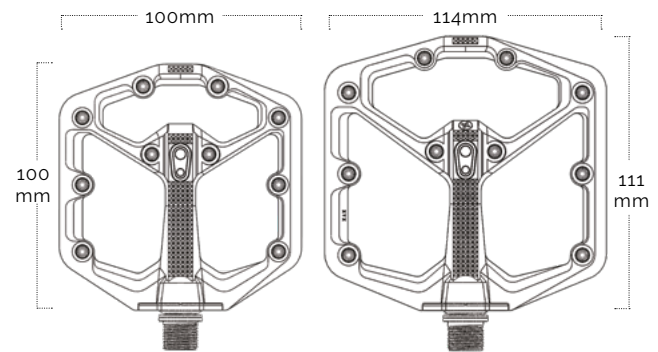

PROFILO MINIMAL/CONCAVITÀ MASSIMA | PROFIL MINIMAL/CONCAVITE MAXIMALE

- Profilo minimal, 11-13 mm
 - Un profilo più fino rispetto alla concorrenza
 - Riduce il peso e l'impatto con le rocce
 - La piattaforma concava garantisce una presa più salda del piede sul pedale
 - Una piattaforma più concava rispetto alla concorrenza
-
- Profil minimal, 11-13 mm
 - Profil plus mince que les produits de la concurrence
 - Réduit le poids et les chocs avec le terrain
 - Plate forme concave, positionnement du pied plus sûr
 - Concavité supérieure aux produits de la concurrence

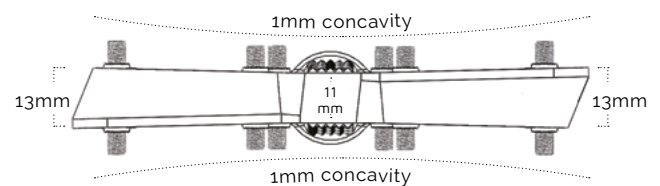



FLAT PEDALS
STAMP



11 STAMP 11



7 STAMP 7

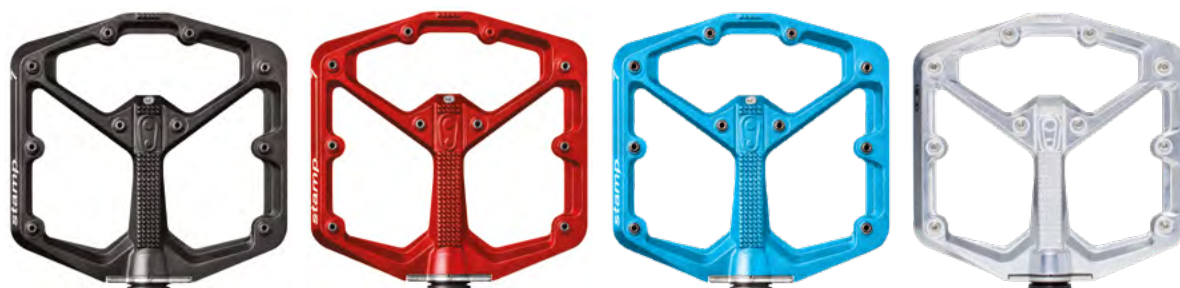

7 STAMP 7
SPLATTER EDITION



ARTICLE	UPC	MODEL	SIZE	BODY COLOR	WEIGHT*	BODY MATERIAL	THICKNESS	PRICE (€)
16165	641300161659	stamp 11 (large)	large	black/gold	325g	aluminum	11/13 mm	300
16166	641300161666	stamp 11 (small)	small	black/gold	299g	aluminum	11/13 mm	300
16002	641300160027	stamp 7 (large)	large	black	375g	aluminum	11/13 mm	180
16003	641300160034		large	red				180
16635	641300166357		large	electric blue				180
16746	641300167460		large	high polish silver				190
16004	641300160041	stamp 7 (small)	small	black	345g	aluminum	11/13 mm	180
16005	641300160058		small	red				180
16636	641300166364		small	electric blue				180
16747	641300167477		small	high polish silver				190
16702	641300167026	stamp 7 (large) splatter edition	large	lime green**	375g	aluminum	11/13 mm	180
16703	641300167033	stamp 7 (small) splatter edition	small	lime green**	345g	aluminum	11/13 mm	180
16705	641300167057		small	red**				180
16707	641300167071		small	blue**				180

(*) Tutti i pesi sono intesi per coppia di pedali | Tous les poids indiqués sont par paire de pédales

(**) Fino ad esaurimento scorte | Jusqu'à épuisement des stocks



FLAT PEDALS STAMP



3 STAMP 3



2 STAMP 2



1 STAMP 1



ARTICLE	UPC	MODEL	SIZE	BODY COLOR	WEIGHT*	BODY MATERIAL	THICKNESS	PRICE (€)
16366	641300163660	stamp 3 (large)	large	black magnesium	386g	magnesium	13.5/16.5 mm	140
16367	641300163677		large	grey magnesium				
16368	641300163684	stamp 3 (small)	small	black magnesium	351g	magnesium	13.5/16.5 mm	140
16369	641300163691		small	grey magnesium				
16362	641300163622	stamp 2 (large)	large	raw silver	494g	die cast aluminum	13.5/16.5 mm	100
16363	641300163639		large	black				
16364	641300163646	stamp 2 (small)	small	raw silver	439g	die cast aluminum	13.5/16.5 mm	100
16365	641300163653		small	black				
16267	641300162670	stamp 1 (large)	large	black	329g	composite	13mm	50
16268	641300162687		large	red				
16269	641300162694		large	blue				
16388	641300163882		large	orange				
16270	641300162700	stamp 1 (small)	small	black	299g	composite	13mm	50
16271	641300162717		small	red				
16272	641300162724		small	blue				
16392	641300163929		small	orange				

(*) Tutti i pesi sono intesi per coppia di pedali | Tous les poids indiqués sont par paire de pédales



STAMP 1 GEN 2 | KEY FEATURES

- Taglia specifica Small/Large per un'interfaccia ottimale tra scarpa e pedale
- Corpo in materiale composito rinforzato leggero, migliora la flessione e riduce il possibile incastramento del pedale nei colpi di roccia
- Piattaforma concava per una presa sicura (spessore di 13,5-15,5 mm)
- 10 pin sostituibili
- Cuscinetti e sistema di tenuta di alta qualità (gli stessi del modello Stamp 7)
- Cuscinetti igus LL-glide (interni ed esterni)
- Perno in acciaio cromato forgiato SCM 435
- Riparabile
- Garanzia di 5 anni

GRIP:

- Piattaforma concava per una presa sicura (spessore di 13,5-15,5 mm)
- 10 pin sostituibili per lato

DURATA:

- Nuova struttura per rinforzare il perno e ridurre i possibili incastramenti del pedale nei colpi di roccia
- Componenti interni premium del modello Stamp 7 per una migliore tenuta e durata

- Taille spécifique Small/Large pour une interface optimale entre la chaussure et la pédale
- Le corps en composite renforcé est léger, améliore la déflexion et réduit l'accrochage lors des chocs avec les pierres
- Plateforme concave pour un maintien du pied sûr (13,5-15,5 mm d'épaisseur)
- 10 picots de traction remplaçables
- Roulements et systèmes d'étanchéité premium (mêmes composants internes que les Stamp 7)
- Roulements igus LL-glide (intérieurs et extérieurs)
- Axe en acier chromoly forgé SCM 435
- Réparable
- Garantie 5 ans

ACCROCHE :

- Plateforme concave pour un maintien du pied sûr (13,5-15,5 mm d'épaisseur)
- 10 picots de traction remplaçables par côté

DURABILITÉ :

- Nouvelle forme du corps pour renforcer l'axe et réduire l'accrochage lors des chocs avec les rochers
- Composants internes premium des Stamp 7 pour une meilleure étanchéité et une plus grande durabilité



FLAT PEDALS STAMP 1 GEN 2

NEW



1 STAMP 1 GEN 2

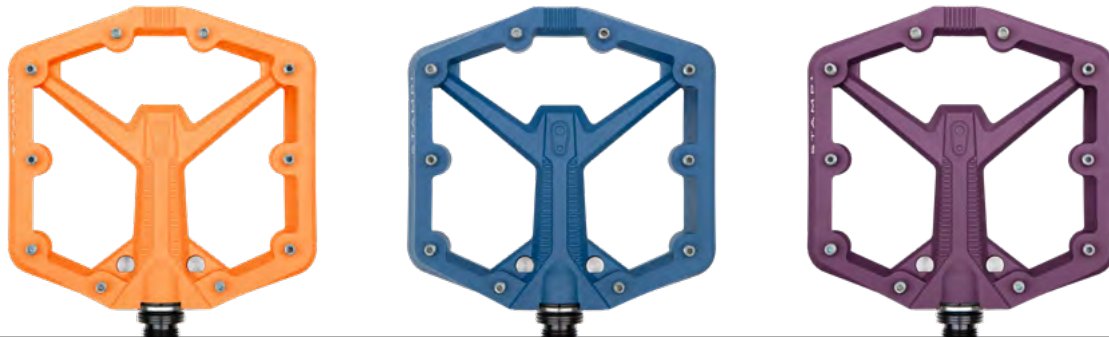
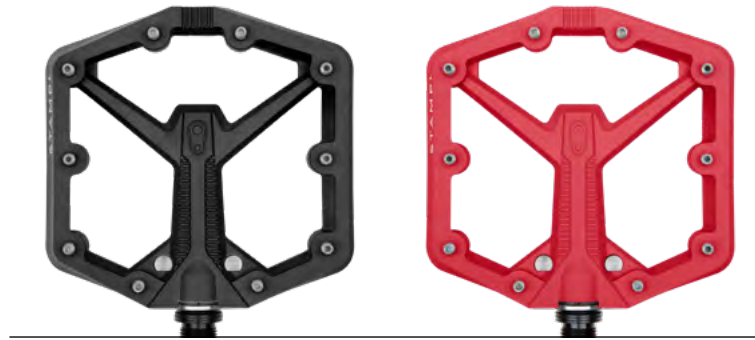

ARTICLE	UPC	NEW	MODEL	SIZE	BODY COLOR	WEIGHT*	BODY MATERIAL	THICKNESS	PRICE (€)
16809	641300168092	NEW	stamp 1 - GEN 2 (large)	large	black	348g	reinforced composite	13.5/15.5mm	60
16811	641300168115	NEW		large	red				60
16813	641300168139	NEW		large	orange				60
16815	641300168153	NEW		large	navy blue				60
16817	641300168177	NEW		large	purple				60
16810	641300168108	NEW	stamp 1 - GEN 2 (small)	small	black	299g	reinforced composite	13.5/15.5mm	60
16812	641300168122	NEW		small	red				60
16814	641300168146	NEW		small	orange				60
16816	641300168160	NEW		small	navy blue				60
16818	641300168184	NEW		small	purple				60

(*) Tutti i pesi sono intesi per coppia di pedali | Tous les poids indiqués sont par paire de pédales

PEDALS ACCESSORIES

CLEAT COLLECTION

STANDARD RELEASE 6° FLOAT CLEAT



GOLD

RELEASE: 15° FLOAT: 6°

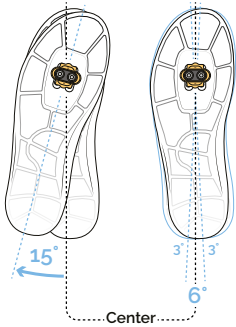

STANDARD RELEASE 0° FLOAT CLEAT



SILVER

RELEASE: 15° FLOAT: 0°

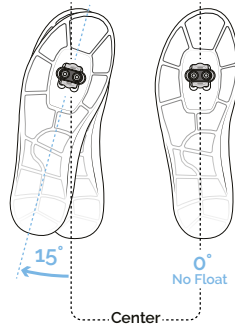

EASY RELEASE 6° FLOAT CLEAT



ROSE

RELEASE: 10° FLOAT: 6°

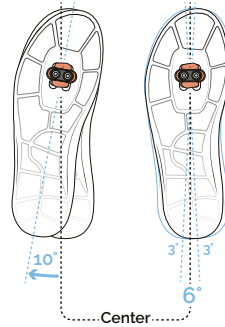

EASY RELEASE 0° FLOAT CLEAT



BRONZE

RELEASE: 10° FLOAT: 0°

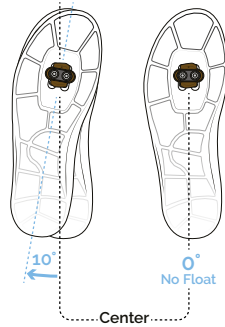

CLEAT POP KIT (INCLUDES 16 PAIRS OF CLEATS)



ARTICLE	UPC	MODEL	PRICE (€)
10060	641300600127	cleat standard release 6 degree	27
15338	641300153388	cleat standard release 0 degree	27
16275	641300162755	cleat easy release 6 degree	27
16276	641300162762	cleat easy release 0 degree	27
16351	641300163516	cleat kit 16 units with fitting tool and display FRENCH	-
16354	641300163547	cleat kit 16 units with fitting tool and display ITALIAN	-



PEDALS ACCESSORIES

CLEAT AND PEDAL ACCESSORIES



MATCH SHOE SHIM

METAL SHOE SHIELDS

3 HOLE ROAD CLEAT

CANDY 7/11 TRACTION PADS

CANDY 2/3 TRACTION PADS 2017 - 2018

CANDY 2/3/11 TRACTION PADS 2010 - 2016

MALLET E/DH TRACTION PADS

EGGBEATER 1mm TRACTION PAD

REFRESH KIT COLLECTION



LONG SPINDLE KIT

TITANIUM SPINDLE KIT

REFRESH KIT

REFRESH KIT EGGBEATER 11 / CANDY 11

REFRESH KIT STAMP 7 / 11

REFRESH KIT DOUBLE SHOT 2 / 3

10MM PIN KIT

8MM PIN KIT

ARTICLE	UPC	COLLECTION	MODEL	PRICE (€)
16685	641300166852	cleat and pedal accessories	match shoe shim	5
10000	641300670007		metal shoes shields/pair	10
15289	641300152893		3 hole cleat kit	30
16057	641300160577		candy 7/11 traction pads	15
16217	641300162175		candy 2/3 traction pads (model 2017)	10
13282	641300132826		candy 2/3/11 traction pads (model 2010-2016)	10
16058	641300160584		mallet e/dh traction pads	15
16509	641300165091		eggbeater 1mm traction pad	10
16067	641300160676	refresh kit collection	long spindle kit	50
16068	641300160683		titanium spindle kit	180
16051	641300160515		refresh kit 2010-present	29
16229	641300162298		refresh kit eggbeater / candy 11	29
16273	641300162731		refresh kit stamp 7/11	25
16274	641300162748		refresh kit double shot 2/3	30
13890	641300138903		flats 10mm pin kit	12
13891	641300138910		flats 8mm pin kit	12



FOOTWEAR

THE CRANKBROTHERS SHOE COLLECTION

LA NUOVA LINEA DI SCARPE E' STATA PROGETTATA CON UN SOLO OBIETTIVO: MIGLIORARE L'ESPERIENZA IN BICI DI OGNI RIDER. ASSECONDANDO LE RICHIESTE PIU' COMUNI RICERCATE SULLE CALZATURE ESISTENTI, QUESTE NUOVE SCARPE SONO STATE DISEGNATE PER OFFRIRE IL PERFETTO BILANCIAMENTO TRA UN'INTERFACCIA OTTIMALE SCARPA-PEDALE CON I REQUISITI RICHIESTI QUANDO SI SCENDE DI BICI.

LA NOUVELLE GAMME DE CHAUSSURES A ÉTÉ CONÇUE AVEC UN SEUL OBJECTIF - CRÉER LA CHAUSSURE VTT LA PLUS ABOUTIE POUR TRAIL ET GRAVITY. PAR RAPPORT AUX MULTIPLES PROBLÈMES COURAMMENT RENCONTRES AVEC LES CHAUSSURES EXISTANTES, ELLES ONT ÉTÉ CONÇUES AFIN D'OFFRIR L'ÉQUILIBRE PARFAIT D'INTERFACE CHAUSSURE-PÉDALE OPTIMISÉE AVEC DES CARACTÉRISTIQUES POUR LA PRATIQUE OFFROAD.



MATCH SYSTEM



PER ABBINARE IL PEDALE CON LA SCARPA POUR ACCOUPLER LA PÉDALE À LA CHAUSSURE

MATCH È UN APPROCCIO DI DESIGN INTEGRATO CHE CONSIDERA IL PEDALE E LA SCARPA
COME UN SISTEMA UNICO CHE ASSICURA L'INTERFACCIA OTTIMALE.

MATCH EST UNE APPROCHE DE CONCEPTION INTÉGRÉE QUI CONSIDÈRE LA PÉDALE ET LA CHAUSSURE
COMME UN SYSTÈME UNIFIÉ POUR FOURNIR L'INTERFACE OPTIMALE.

MATCH SHIM CHART



SPD



CRANKBROTHERS



CLEAT ONLY

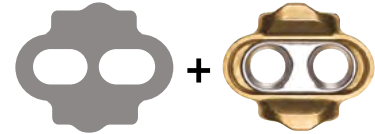

SHIM + CLEAT

OTTIMIZZATO PER OGNI SISTEMA DI AGGANCO DELLE MTB
OPTIMISÉ POUR TOUT SYSTÈME DE PÉDALES AUTOMATIQUES DE VTT

INGAGGIO OTTIMIZZATO PER SISTEMI DI AGGANCO CRANKBROTHERS
 INGAGGIO DUREVOLE CON I PEDALI CRANKBROTHERS

OPTIMISÉ POUR L'ENCLENCHEMENT DES PÉDALES CRANKBROTHERS ENCLENCHEMENT DURABLE
 AVEC LES PÉDALES CRANKBROTHERS

SHIM THICKNESS CHART:		PEDALS			
GREY: 1.5mm BLACK: 1mm BLACK: 1mm					
		MALLET DH	MALLET E	MALLET TRAIL	CANDY
SHOES					X
	MALLET	PRE-INSTALLED	PRE-INSTALLED	USE BLACK SHIM INCLUDED WITH PEDALS / USE #16917 (AVAILABLE SEPARATELY)	SHIM NOT RECOMMENDED
					X
	MALLET E	PRE-INSTALLED	PRE-INSTALLED	USE BLACK SHIM INCLUDED WITH PEDALS / USE #16917 (AVAILABLE SEPARATELY)	SHIM NOT RECOMMENDED
MALLET TRAIL	INCLUDED IN SHOE PACKAGING	INCLUDED IN SHOE PACKAGING	PRE-INSTALLED	PRE-INSTALLED	
	X	X			
CANDY XC	SHIM NOT RECOMMENDED	SHIM NOT RECOMMENDED	USE BLACK SHIM INCLUDED WITH PEDALS / USE #16917 (AVAILABLE SEPARATELY)	USE BLACK SHIM INCLUDED WITH PEDALS / USE #16917 (AVAILABLE SEPARATELY)	



MATCH BOX



ACCESSO E USCITA FACILI
ENCLÈNCHÈMENT ET DÉENCLÈNCHÈMENT FACILES

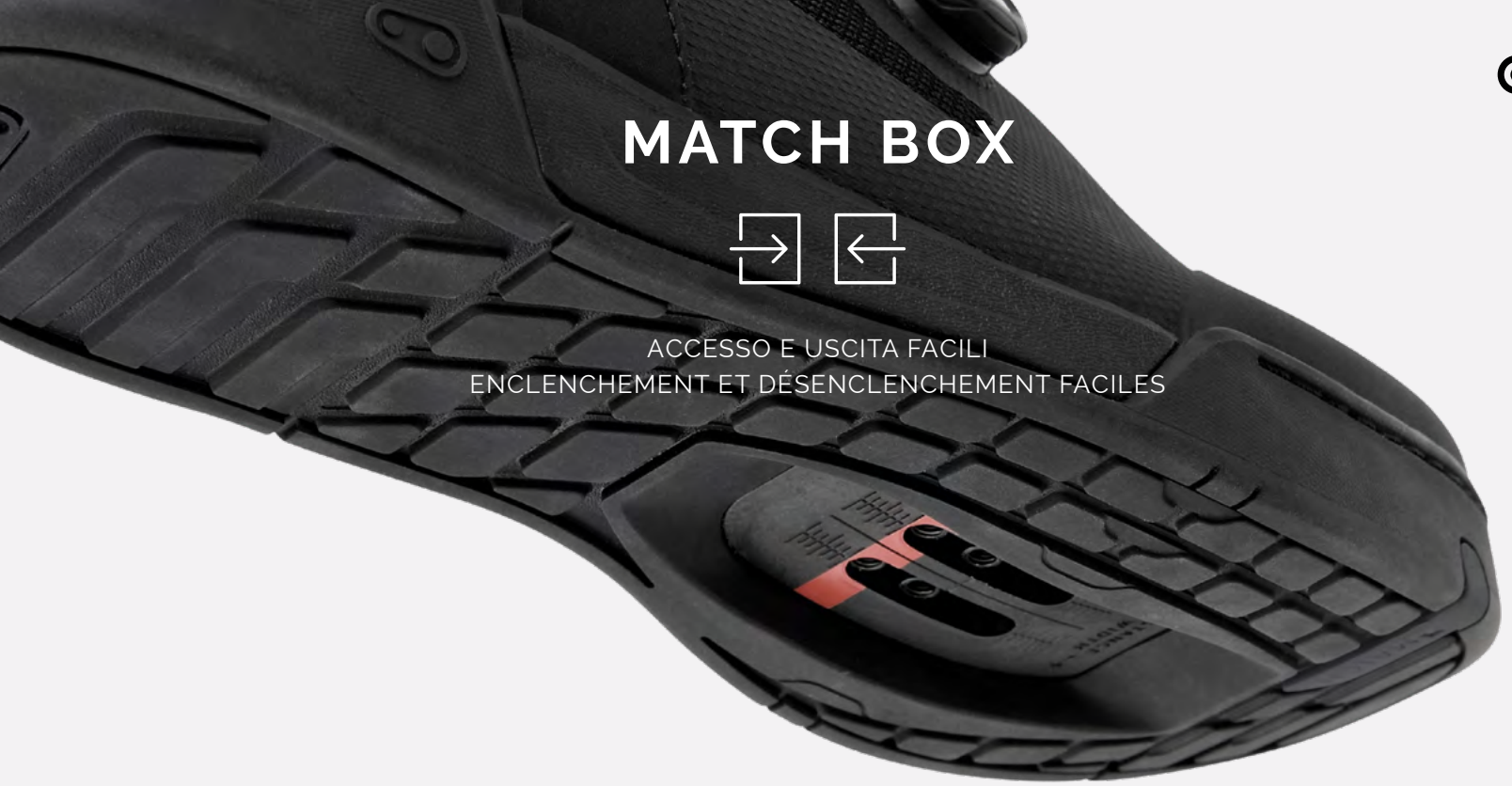

PRONTI DA USARE | PRÊT À ROULER



ESPERIENZA D'ACQUISTO MIGLIORATA
TACCHETTA PREINSTALLATA IN POSIZIONE NEUTRALE SU TUTTE LE SCARPE CLIP-IN
AD ECCEZIONE DEL MODELLO CANDY

EXPÉRIENCE D'ACHAT AMÉLIORÉE
LA CALE EST PRÉ-INSTALLÉE EN POSITION NEUTRE SUR TOUTES LES CHAUSSURES CLIP-IN,
À L'EXCEPTION DU MODÈLE CANDY.

TRAIL SHOES RANGE

CARATTERISTICHE DELLA TOMAIA | CARACTERISTIQUES DE L'EMPEIGNE BOA SYSTEM E STRAP



CLIP-IN OUTSOLE

MATCH OUTSOLE

- Disegno del battistrada progettato per offrire trazione anche mentre si cammina
- Tacchetti sulla punta e sul tallone orientati in modo angolato e distanziato per garantire trazione durante le escursioni su terreni ripidi in salita o discesa
- Punta inclinata per una camminata migliore
- Struttura rigida in nylon rinforzato da fibra per un efficiente trasferimento di potenza
- Rivestimento in gomma della parte anteriore per una protezione extra della punta
- Motif de la bande de roulement conçu pour l'adhérence en dehors du vélo
- Les ergots directionnels angulaires et espacés au niveau des orteils et du talon offrent une bonne adhérence pour les randonnées sur terrains escarpés
- Bout en forme de rampe pour une marche facilité
- Tige rigide en nylon renforcé de fibres pour le transfert de puissance
- Caoutchouc enveloppé à l'avant pour une protection supplémentaire des orteils

MATCH COMPOUND

- Composto in gomma mc1 a media aderenza che consente un facile inserimento e sgancio del pedale
- Resistenza migliorata all'usura e agli strappi
- Tacchetti arrotondati per diminuire l'abrasione
- Le composé de caoutchouc mc1 à friction moyenne facilite l'entrée et la sortie de la pédale
- Résistance accrue à l'usure et à la déchirure
- Cosses arrondies pour une meilleure résistance à l'abrasion





CARATTERISTICHE DELLA TOMAIA | CARACTERISTIQUES DE L'EMPEIGNE LACE UP



FLAT OUTSOLE



MATCH OUTSOLE

- I tasselli profondi, posizionati in modo uniforme, sono progettati per garantire una presa sicura sui pin
- I tasselli della punta e del tallone sono inclinati e spaziosi in modo direzionale per offrire trazione durante la salita o la discesa su terreni ripidi
- Il disegno del battistrada è progettato per garantire trazione mentre si cammina
- La punta inclinata permette una camminata migliore
- Intersuola in Eva per smorzare le vibrazioni
- Rivestimento in gomma nella parte anteriore per una protezione extra delle dita dei piedi
- Les ergots profonds et régulièrement placés sont conçus pour sécuriser les picots
- Les ergots directionnels et espacés au niveau des orteils et du talon offrent l'adhérence pour les randonnées en terrain escarpé
- La bande de roulement est conçue pour la traction en dehors du vélo
- Le bout de la chaussure est arrondi pour faciliter la marche
- Semelle intermédiaire Eva pour amortir les vibrations
- Avant enveloppé en caoutchouc pour une protection supplémentaire des orteils

MATCH COMPOUND

- La mescola è ottimizzata per una presa solida e una maggiore durata
- Ha un elevato grip per aderire al meglio al corpo del pedale e una bassa capacità di rimbalzo per smorzare le vibrazioni
- I tasselli sono arrotondati per resistere all'abrasione
- Composé optimisé pour l'adhérence et la durabilité
- Possède un fort coefficient de friction pour adhérer au corps de la pédale et de faibles propriétés de rebond pour amortir les vibrations
- Les ergots sont arrondis pour résister à l'abrasion

CLIP-IN SHOES
MALLET TRAIL BOA

NEW



MALLET TRAIL LACE

NEW



ARTICLE	NEW	MODEL	STYLE	COLOR	OUSOLE	CLOSURE	SIZE	WEIGHT	PRICE (€)
MTB41080A	NEW	mallet trail boa	clip-in	black/gold	gum	boa + strap	37-49	410g (single - size 42)	220
MTL41010A	NEW			black/black	gum				170
MTL42095A	NEW	mallet trail lace	clip-in	white/purple	purple	lace	37-49	385g (single - size 42)	170
MTL44040A	NEW			blue/blue	gum				170

Tutti i modelli sono disponibili nelle taglie piene | Tous les modèles sont disponibles en tailles pleines



FLAT SHOES
STAMP TRAIL BOA

NEW



STAMP TRAIL LACE

NEW



ARTICLE	NEW	MODEL	STYLE	COLOR	OUSOLE	CLOSURE	SIZE	WEIGHT	PRICE (€)
TRB41080A	NEW	stamp trail boa	flat	black/gold	gum	boa + strap	37-49	320g (single - size 42)	200
TRL41010A	NEW			black/black	gum				150
TRL42095A	NEW	stamp trail lace	flat	white/purple	purple	lace	35-49	295g (single - size 42)	150
TRL44040A	NEW			blue/blue	gum				150

Tutti i modelli sono disponibili nelle taglie piene | Tous les modèles sont disponibles en tailles pleines

MALLET, MALLET E, STAMP RANGE

CARATTERISTICHE DELLA TOMAIA | CARACTERISTIQUES DE L'EMPEIGNE
LACE UP



MATERIALI PREMIUM MATÉRIAUX DE QUALITÉ SUPÉRIEURE

TRASPIRABILITÀ/RESPIRABILITÉ

Materiali traforati e inserti ventilanti in mesh garantiscono massima traspirabilità.
Les matériaux perforés et les ouvertures en mesh ventilé assurent la respirabilité.

PROTEZIONE/PROTECTION

Punta realizzata in materiali rinforzati per protezione dagli impatti.
Les matériaux renforcés au niveau des orteils offrent une protection contre les impacts.

COMFORT/CONFORT

Linguetta e fodera tallone imbottite per massimo comfort durante tutta la giornata.
La languette et les talons rembourrés offrent un confort tout au long de la journée
et un ajustement supérieur.



TRE TIPOLOGIE DI CHIUSURA TROIS OPTIONS DE FERMETURE

BOA® SYSTEM & STRAP

Un rotore microregolabile, un robusto e leggero laccio e passanti a bassa frizione per ottenere una calzata veloce, comoda e precisa. Disegnato per consentire regolazioni indipendentemente dalle condizioni, il BOA® ti garantirà il controllo immediato sul tuo riding semplicemente con una mano, per una regolazione al volo.

Une molette de micro-adjustement, un lacet solide et léger et des guides de lacet à faible friction permettent un ajustement rapide, sans effort et précis. Conçu pour permettre des modifications de réglages quelles que soient les conditions, BOA® garantit que vous aurez un contrôle instantané tout en roulant, par un simple réglage d'une seule main.



SPEED LACE & STRAP

Il sistema di chiusura con laccio rapido offre una regolazione facile, uno strap per una chiusura sicura e una tasca per alloggiare i lacci in sicurezza.

Le système de fermeture à lacets permet un ajustement rapide, une sangle procure une fermeture sécurisée et une poche afin de ranger les lacets en toute sécurité.



LACE UP

La classica chiusura a laccio offre una ritenzione dolce con lacci rotondi e una tasca per alloggiarli in sicurezza.

Le système de fermeture classique à lacets ronds procure un serrage en douceur. Une poche permet de les ranger en toute sécurité.



CLIP-IN SHOES
MALLET BOA



CLIP-IN SHOES
MALLET SPEEDLACE





CLIP-IN SHOES
MALLET LACE



PUMPFORPEACE EDITION



SPLATTER EDITION



SPLATTER EDITION

ARTICLE	MODEL	STYLE	COLOR	OUSOLE	CLOSURE	SIZE	WEIGHT	PRICE (€)
MAB01080A	mallet boa	clip-in	black/gold	black	boa + strap	37-49	429g (single - size 42)	200
MAS01020A	mallet speedlace	clip-in	black/white	black	speedlace + strap	37-48	428g (single - size 42)	170
MAL01030A	mallet lace	clip-in	black/red	black	lace	37-48	415g (single - size 42)	150
MAL13010A	mallet lace pumpforpeace edition	clip-in	red/black*	gum	lace	37-48	415g (single - size 42)	160
MAL17040S	mallet lace splatter edition	clip-in	grey/blue*	gum	lace	37-48	415g (single - size 42)	150
MAL15152S	mallet lace splatter edition	clip-in	petrol/lime*	gum	lace	37-48	415g (single - size 42)	150

Tutti i modelli sono disponibili nelle taglie piene | Tous les modèles sont disponibles en tailles pleines

(*) Fino ad esaurimento scorte | Jusqu'à épuisement des stocks

CLIP-IN SHOES
MALLET E BOA



CLIP-IN SHOES
MALLET E SPEEDLACE





CLIP-IN SHOES
MALLET E LACE



ARTICLE	MODEL	STYLE	COLOR	OUSOLE	CLOSURE	SIZE	WEIGHT	PRICE (€)
MEB01080A	mallet e boa	clip-in	black/gold*	black	boa + strap	37-48	439g (single - size 42)	200
MES05443A	mallet e speedlace	clip-in	green/blue*	gum	speedlace + strap	37-48	437g (single - size 42)	170
MEL01043A	mallet e lace	clip-in	black/blue*	black	lace	37-48	432g (single - size 42)	150

Tutti i modelli sono disponibili nelle taglie piene | Tous les modèles sont disponibles en tailles pleines

(*) Fino ad esaurimento scorte | Jusqu'à épuisement des stocks

FLAT SHOES
STAMP BOA



FLAT SHOES
STAMP SPEEDLACE





FLAT SHOES
STAMP LACE



PUMPFORPEACE EDITION



SPLATTER EDITION



SPLATTER EDITION

ARTICLE	MODEL	STYLE	COLOR	OUSOLE	CLOSURE	SIZE	WEIGHT	PRICE (€)
STB01080A	stamp boa	flat	black/gold	black	boa + strap	37-49	379g (single - size 42)	180
STS21020A			black/white	black				150
STS29546A	stamp speedlace	flat	purple/teal blue	gum	speedlace + strap	37-48	383g (single - size 42)	150
STS05435A			green/orange*	black				150
STS07030A			grey/red*	black				150
STL04281A			black/silver			35-48		130
STL02086A	stamp lace	flat	white/white	gum	lace	35-48	376g (single - size 42)	130
STL01081A			navy/silver			37-49		130
STL13010P	stamp lace pumpforpace edition	flat	red/black*	gum	lace	37-48	376g (single - size 42)	140
STL17040S	stamp lace splatter edition	flat	grey/blue*	gum	lace	37-48	376g (single - size 42)	130
STL15152S			petrol/lime*					130

Tutti i modelli sono disponibili nelle taglie piene | Tous les modèles sont disponibles en tailles pleines

(*) Fino ad esaurimento scorte | Jusqu'à épuisement des stocks

FLAT SHOES
STAMP STREET LACE



ARTICLE	MODEL	STYLE	COLOR	OUSOLE	CLOSURE	SIZE	WEIGHT	PRICE (€)
SSL11080F	stamp	flat	black/gold	gum	lace	35-48	570g (single - size 42)	130
SSL12080F	street lace		white/gold					130

Tutti i modelli sono disponibili nelle taglie piene | Tous les modèles sont disponibles en tailles pleines



CANDY GRAVEL / XC SHOE

CARATTERISTICHE DELLA TOMAIA | CARACTERISTIQUES DE L'EMPEIGNE

LACE UP



LASER-CUT MATERIALS
AND PERFORATED TONGUE
FOR BREATHABILITY

LACE CLOSURE SYSTEM,
WITH ELASTIC RETENTION LOOP
TO KEEP THINGS IN CHECK

PU FILM FOR ABRASION
RESISTANCE AND EASY
CLEANING

TPU TOE
PROTECTION

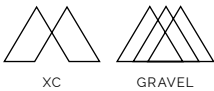

CLIP-IN OUTSOLE

MATCH OUTSOLE

- Suola in gomma e disegno del battistrada progettati per garantire trazione anche mentre si cammina
- Lungo canale centrale per un inserimento fluido del pedale e per facilitare la rimozione del fango
- Possibilità di scegliere la posizione ottimale delle tacchette grazie a una pista di 35 mm
- Zona antiscivolo nel caso in cui il pedale non venga agganciato
- La semelle extérieure en caoutchouc et la bande de roulement sont conçues pour la traction en dehors du vélo
- Long canal central pour un accès ininterrompu à la pédale et une évacuation de la boue
- Possibilité de choisir la position optimale de la cale grâce à un espace de cale étendu de 35 mm
- Zone antidérapante si vous ne vous engagez pas sur la pédale

MATCH COMPOUND

- Il composto di gomma mc1 a media aderenza consente un facile inserimento e sgancio del pedale
- Resistenza migliorata all'usura e alle sollecitazioni
- Tacchetti arrotondati per resistere all'abrasione
- Le composé de caoutchouc mc1 à friction moyenne facilite l'entrée et la sortie de la pédale.
- Résistance accrue à l'usure et à la déchirure
- Cosses arrondies pour résister à l'abrasion





CLIP-IN SHOES

CANDY GRAVEL / XC LACE

NEW



ARTICLE	NEW	MODEL	STYLE	COLOR	OUSOLE	CLOSURE	SIZE	WEIGHT	PRICE (€)
CGL41010A	NEW	candy gravel/xc lace	clip-in	black/black	gum	lace	37-49	340g (single - size 42)	160
CGL42070A	NEW			white/grey	grey				160

Tutti i modelli sono disponibili nelle taglie piene | Tous les modèles sont disponibles en tailles pleines

SOCKS
ICON MTB SOCKS



WHITE / PURPLE



WHITE / RED / BLACK



BLACK / GOLD / GREY



BLACK / RED / GREY



WHITE / BROWN / BLACK



BLUE / WHITE

ARTICLE	UPC	NEW	MODEL	COLOR	SIZE	PRICE (€)
81333	641300813336	NEW	icon mtb sock	white/purple	small/medium	19,90
81334	641300813343	NEW		white/purple	large/x-large	19,90
81254	641300812544	NEW		white/red/black	small/medium	15,90
81255	641300812551	NEW		white/red/black	large/x-large	15,90
81223	641300812230			black/gold/grey	small/medium	15,90
81224	641300812247			black/gold/grey	large/x-large	15,90
81232	641300812322			black/red/grey*	small/medium	15,90
81230	641300812308			white/brown/black	small/medium	15,90
81231	641300812315			white/brown/black	large/x-large	15,90
81228	641300812285			navy blue/white	small/medium	15,90
81229	641300812292			navy blue/white	large/x-large	15,90

(*) Fino ad esaurimento scorte | Jusqu'à épuisement des stocks



LACES

BOA REPLACEMENT KIT

NEW



SPEEDLACE

NEW



PINK



BLACK



RED



ORANGE



LIGHT BLUE



WHITE



SILVER

ARTICLE	UPC	NEW	MODEL	COLOR	SIZE	PRICE (€)
16751	641300167514	NEW	BOA Li2 replacement kit	black	TU	30,00
16638	641300166388		BOA L6 replacement kit	black	TU	22,00
16738	641300167385	NEW	speedlace	pink	TU	10,90
16639	641300166395			black	TU	10,90
16640	641300166401			red	TU	10,90
16641	641300166418			orange	TU	10,90
16642	641300166425			light blue	TU	10,90
16643	641300166432			white	TU	10,90
16644	641300166449			silver	TU	10,90

LACES
ROUNDED LACE

NEW



PINK



BLACK



RED



ORANGE



LIGHT BLUE



WHITE



SILVER

ARTICLE	UPC	NEW	MODEL	COLOR	SIZE	PRICE (€)
16736	641300167361	NEW	rounded lace	pink	small/medium	5,90
16737	641300167378	NEW			large/x-large	5,90
16645	641300166456			black	small/medium	5,90
16657	641300166579				large/x-large	5,90
16646	641300166463			red	small/medium	5,90
16658	641300166586				large/x-large	5,90
16647	641300166470			orange	small/medium	5,90
16659	641300166593				large/x-large	5,90
16648	641300166487			light blue	small/medium	5,90
16660	641300166609				large/x-large	5,90
16649	641300166494			white	small/medium	5,90
16661	641300166616				large/x-large	5,90
16650	641300166500			silver	small/medium	5,90
16662	641300166623				large/x-large	5,90



LACES
FLAT LACE

NEW



BLACK



WHITE



SAGE GREEN



SILVER



ORANGE



BLUE



PINK

ARTICLE	UPC	NEW	MODEL	COLOR	SIZE	PRICE (€)
16729	641300167293	NEW	flat lace	black	small/medium	5,90
16739	641300167392	NEW			large/x-large	5,90
16730	641300167309	NEW		white	small/medium	5,90
16740	641300167408	NEW			large/x-large	5,90
16731	641300167316	NEW		sage green	small/medium	5,90
16741	641300167415	NEW			large/x-large	5,90
16732	641300167323	NEW		silver	small/medium	5,90
16742	641300167422	NEW			large/x-large	5,90
16733	641300167330	NEW		orange	small/medium	5,90
16743	641300167439	NEW			large/x-large	5,90
16734	641300167347	NEW		blue	small/medium	5,90
16744	641300167446	NEW			large/x-large	5,90
16735	641300167354	NEW		pink	small/medium	5,90
16745	641300167453	NEW			large/x-large	5,90



WHEELS

SYNTHESIS

TUNED WHEEL
SYSTEM

LE RUOTE SYNTHESIS CARBON HANNO UNA GARANZIA A VITA.
DETTAGLI SU [CRANKBROTHERS.COM](https://www.crankbrothers.com)

LES ROUES SYNTHESIS CARBON OFFRENT UNE GARANTIE À VIE.
POUR PLUS D'INFORMATIONS ALLEZ SUR [CRANKBROTHERS.COM](https://www.crankbrothers.com)



ANTERIORE E POSTERIORE SPECIFICI | AVANT ET ARRIERE SPECIFIQUES

UN SISTEMA RUOTA PERSONALIZZATO PAIRE DE ROUES PERSONNALISEES

STRUTTURA RUOTA ANTERIORE

- Ridotto numero di raggi
- Tensione sui raggi inferiore
 - Raggi alleggeriti
 - Cerchio alleggerito
- Canale del cerchio più largo

STRUCTURE ROUE AVANT

- Nombre de rayons réduit
- Tension des rayons inférieure
 - Rayons allégés
 - Jante allégée
- Profil intérieur de la jante plus large

STRUTTURA RUOTA POSTERIORE

- Maggiore numero di raggi
- Tensione sui raggi maggiore
- Maggiore robustezza del raggio
 - Cerchio più resistente
- Canale del cerchio più stretto

STRUCTURE ROUE ARRIÈRE

- Nombre de rayons plus élevés
- Tension des rayons supérieure
 - Rayons renforcés
 - Jante plus résistante
- Profil intérieur de la jante plus étroit

CONTROLLO NELLE CURVE | MAITRISE EN COURBE

UNA RUOTA ANTERIORE MANEGGEVOLE ROUE AVANT PLUS MANIABLE



MANEGGEVOLEZZA OTTIMIZZATA

- Smorza le vibrazioni sui trail
- Riduce la stanchezza del biker
- Attutisce e assorbe gli impatti

CONDUITE PLUS MANIABLE

- Amortit les vibrations
- Réduit la fatigue du pilote
- Diminue et absorbe les chocs



TRAIETTORIE SICURE

- Migliora l'aderenza
- Migliora l'ingresso in curva in velocità
- Tiene la copertura attaccata al suolo

TRAJECTOIRES MAITRISEES

- Améliore l'adhérence
- Améliore la vitesse en courbe
- Maintient l'accroche du pneu au sol



CANALE DEL CERCHIO A LARGHEZZA MAGGIORATA

- Aumenta il volume d'aria della copertura per una migliore aderenza
- Il profilo arrotondato della copertura migliora le sterzate
- Supporta le coperture di grossa sezione sull'anteriore

PROFIL INTÉRIEUR DE LA JANTE PLUS LARGE

- Augmentation du volume d'air du pneu améliorant l'adhérence
- Le profil arrondi du pneu facilite le guidage en virage
- Supporte le montage de pneus de grosse section sur la roue avant

STABILITÀ E CONTROLLO IN VELOCITÀ | STABILITÉ ET CONTRÔLE À VITESSE ÉLEVÉE

UNA RUOTA POSTERIORE RIGIDA UNE ROUE ARRIERE RIGIDE

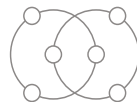

CARICHI DIREZIONALI / RADIALI TOLLERATI PERFETTAMENTE

- Reattività
- Mantiene velocità e momento di inerzia
 - Stabilità
- Tollera le compressioni
- Ancora il biker al centro di gravità

SUPPORTE PARFAITEMENT LES CHARGES DIRECTIONNELLES ET RADIALES

- Réactivité
- Vitesse maintenue et moment d'inertie
 - Stabilité
- Absorbe les pics de compression
- Maintient le centre de gravité du pilote



CANALE DEL CERCHIO PIÙ STRETTO

- Riduce le pizzicature
- Migliora la resistenza al rotolamento
- Tassellatura più pronunciata per l'aderenza

PROFIL INTÉRIEUR DE LA JANTE PLUS ÉTROIT

- Réduit la zone de contact
- Diminue la résistance au roulement
- Améliore l'adhérence du pneu

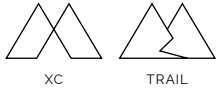

CARBON WHEELSETS

SYNTHESIS XCT 11

PRECISA IN VELOCITÀ | GUIDAGE PRECIS A HAUTE VITESSE

HUB

SYNTHESIS 11 (INDUSTRY NINE HYDRA HUB)

ENGAGEMENT

0.52" QUICK ENGAGEMENT / SIX PAWLS

SPOKES

SAPIM CX-RAY (FRONT)

SAPIM CX-RAY (REAR)



FRONT



REAR

COMPLIANT FRONT WHEEL

SPOKE COUNT: 28
INNER RIM WIDTH: 26.5

STIFF REAR WHEEL

SPOKE COUNT: 32
INNER RIM WIDTH: 24.5

OUTER RIM WIDTH

OUTER RIM WIDTH FRONT: 31.1 MM
REAR: 29.5 MM

ARTICLE	UPC	MODEL	DIAMETER	HUB	DRIVER BODY	FRONT AXLE	REAR AXLE	RIM	WEIGHT	PRICE (€)
16299	641300162991	synthesis xct 11	29"	boost i9	xd	110x15 mm	148x12 mm	carbon premium	1519g	2400
16464	641300164643		29"	boost i9	shimano micro spline	110x15 mm	148x12 mm	carbon premium	1764g	2400



CARBON WHEELSETS
SYNTHESIS E 11

CONTROLLO E STABILITÀ PER L'ENDURO | CONTRÔLE ET STABILITÉ EN PRATIQUE ENDURO

HUB
INDUSTRY NINE HYDRA HUB

ENGAGEMENT
0.52" QUICK ENGAGEMENT / SIX PAWLS

SPOKES
SAPIM CX-RAY (FRONT)
SAPIM CX-SPRINT (REAR)



FRONT



REAR

COMPLIANT FRONT WHEEL

SPOKE COUNT: 28
INNER RIM WIDTH: 31.5

STIFF REAR WHEEL

SPOKE COUNT: 32
INNER RIM WIDTH: 29.5

OUTER RIM WIDTH

OUTER RIM WIDTH FRONT: 37.5 MM
OUTER RIM WIDTH REAR: 36.5 MM

ARTICLE	UPC	MODEL	DIAMETER	HUB	DRIVER BODY	FRONT AXLE	REAR AXLE	RIM	WEIGHT	PRICE (€)
16448	641300164483	synthesis e 11	27.5"	boost i9	shimano micro spline	110x15 mm	148x12 mm	carbon premium	1760g	2400
16449	641300164490		27.5"	super boost 157 i9	xd	110x15 mm	157x12mm	carbon premium	1760g	2400
16454	641300164544		29"	boost i9	shimano micro spline	110x15 mm	148x12 mm	carbon premium	1825g	2400
16455	641300164551		29"	super boost 157 i9	xd	110x15 mm	157x12mm	carbon premium	1825g	2400
16446	641300164469		27.5"	boost i9	xd	110x15 mm	148x12 mm	carbon premium	1760g	2400
16452	641300164520		29"	boost i9	xd	110x15 mm	148x12 mm	carbon premium	1825g	2400



CARBON SINGLE WHEEL

SYNTHESIS GRAVEL CARBON

NEW

DOVE IL COMFORT INCONTRA LA PERFORMANCE | QUAND LE CONFORT RENCONTRE LA PERFORMANCE

HUB
SYNTHESIS RATCHET

ENGAGEMENT
10°

SPOKES
SAPIM D-LIGHT

SIZES
700 C / 650 B

WEIGHT
700 C: 1544g / 650 B: 1517G

TUBELESS READY



FRONT

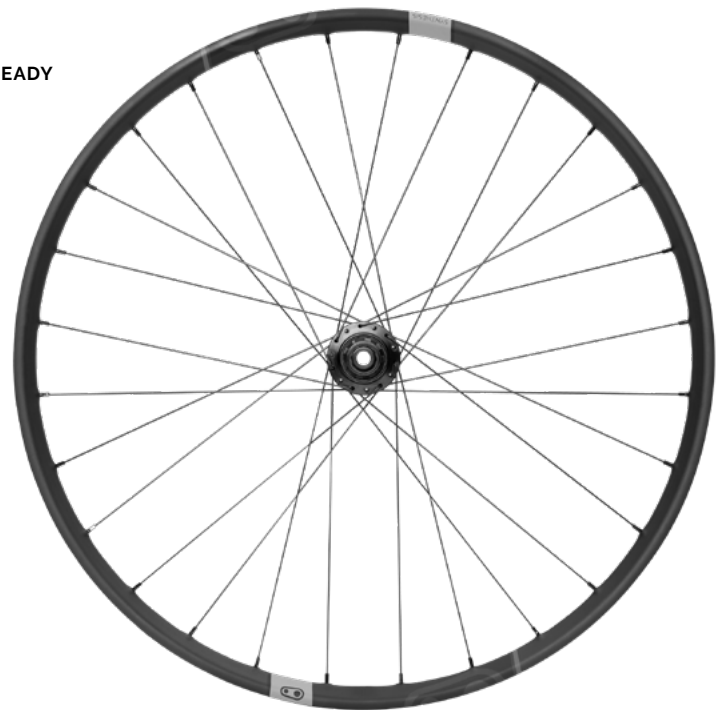

REAR

FRONT WHEEL

SPOKE COUNT: 28
INNER RIM WIDTH: 26.5

REAR WHEEL

SPOKE COUNT: 28
INNER RIM WIDTH: 26.5

ARTICLE	UPC	NEW	MODEL	DIAMETER	HUB	DRIVER BODY	FRONT AXLE	REAR AXLE	RIM	WEIGHT	PRICE (€)
16825	641300168252	NEW	synthesis gravel carbon	700c front	CB ratchet	-	12X100 mm	-	26.5mm	716g	600
16826	641300168269	NEW		700c rear	CB ratchet	XDR	-	142x12 mm	26.5mm	833g	900
16827	641300168276	NEW		700c rear	CB ratchet	HG	-	142x12 mm	26.5mm	836g	900
16828	641300168283	NEW		650b front	CB ratchet	-	12X100 mm	-	26.5mm	698g	600
16829	641300168290	NEW		650b rear	CB ratchet	XDR	-	142x12 mm	26.5mm	819g	900
16830	641300168306	NEW		650b rear	CB ratchet	HG	-	142x12 mm	26.5mm	826g	900



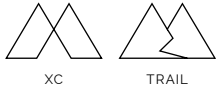

ALLOY SINGLE WHEEL SYNTHESIS XCT ALLOY

PRECISA IN VELOCITÀ | GUIDAGE PRECIS A HAUTE VITESSE

HUB
SYNTHESIS STANDARD HUB

ENGAGEMENT
4'

SPOKES
SAPIM D-LIGHT (FRONT)
SAPIM RACE (REAR)



FRONT



REAR

COMPLIANT FRONT WHEEL

SPOKE COUNT: 28 INNER RIM WIDTH: 26.5

STIFF REAR WHEEL

SPOKE COUNT: 32 INNER RIM WIDTH: 24.5

ARTICLE	UPC	MODEL	DIAMETER	DRIVER BODY	HUB	FRONT AXLE	REAR AXLE	RIM	WEIGHT	PRICE (€)
16418	641300164186	synthesis alloy xct	29" front	-	boost	110x15 mm	148x12 mm	aluminum	841g	240
16419	641300164193		29" rear	xd	boost	110x15 mm	148x12 mm	aluminum	998g	360
16421	641300164216		29" rear	shimano micro spline	boost	110x15 mm	148x12 mm	aluminum	998g	360



ALLOY SINGLE WHEEL

SYNTHESIS E ALLOY

CONTROLLO E STABILITÀ PER L'ENDURO | CONTRÔLE ET STABILITÉ EN PRATIQUE ENDURO

HUB
SYNTHESIS STANDARD HUB

ENGAGEMENT
4°
17°

SPOKES
SAPIM D-LIGHT (FRONT)
SAPIM RACE (REAR)



FRONT



REAR

COMPLIANT FRONT WHEEL

SPOKE COUNT: 28 INNER RIM WIDTH: 31.5

STIFF REAR WHEEL

SPOKE COUNT: 32 INNER RIM WIDTH: 29.5

ARTICLE	UPC	MODEL	DIAMETER	DRIVER BODY	HUB	FRONT AXLE	REAR AXLE	RIM	WEIGHT	PRICE (€)
16406	641300164063	synthesis alloy enduro	27.5" front	-	boost	110x15 mm	148x12 mm	aluminum	877g	240
16407	641300164070		27.5" rear	xd	boost	110x15 mm	148x12 mm	aluminum	1062g	360
16409	641300164094		27.5" rear	shimano micro spline	boost	110x15 mm	148x12 mm	aluminum	1062g	360
16410	641300164100		29" front	-	boost	110x15 mm	148x12 mm	aluminum	902g	240
16411	641300164117		29" rear	xd	boost	110x15 mm	148x12 mm	aluminum	1095g	360
16413	641300164131		29" rear	shimano micro spline	boost	110x15 mm	148x12 mm	aluminum	1095g	360



ELECTRIC

ALLOY SINGLE WHEEL SYNTHESIS E-BIKE ALLOY

COSTRUITA PER E-MTB | CONSTRUIT POUR E-MTB

HUB

SYNTHESIS STANDARD HUB

ENGAGEMENT

17'

SPOKES

S APIM E-LIGHT (FRONT)

S APIM STRONG (REAR)



FRONT



REAR

SIZES: 27.5 - 29

SIZE: 27.5+

COMPLIANT FRONT WHEEL

STIFF REAR WHEEL

COMPLIANT FRONT WHEEL

STIFF REAR WHEEL

SPOKE COUNT:
28

INNER RIM
WIDTH:
31.5

SPOKE COUNT:
32

INNER RIM
WIDTH:
31.5

SPOKE COUNT:
28

INNER RIM
WIDTH:
35.5

SPOKE COUNT:
32

INNER RIM
WIDTH:
35.5

ARTICLE	UPC	MODEL	DIAMETER	DRIVER BODY	HUB	FRONT AXLE	REAR AXLE	RIM	WEIGHT	PRICE (€)
16422	641300164223	synthesis alloy e-mtb	27.5" plus/front	-	boost	110x15 mm	148x12 mm	aluminum	928g	300
16423	641300164230		27.5" plus/rear	xd	boost	110x15 mm	148x12 mm	aluminum	1181g	400
16425	641300164254		27.5" plus/rear	shimano micro spline	boost	110x15 mm	148x12 mm	aluminum	1181g	400
16426	641300164261		29" front	-	boost	110x15 mm	148x12 mm	aluminum	980g	300
16427	641300164278		29" rear	xd	boost	110x15 mm	148x12 mm	aluminum	1238g	400
16429	641300164292		29" rear	shimano micro spline	boost	110x15 mm	148x12 mm	aluminum	1238g	400



ALLOY SINGLE WHEEL

SYNTHESIS GRAVEL ALLOY

NEW

DOVE IL COMFORT INCONTRA LA PERFORMANCE | QUAND LE CONFORT RENCONTRE LA PERFORMANCE

HUB
SYNTHESIS STANDARD

ENGAGEMENT
17°

SPOKES
SAPIM D-LIGHT

SIZES
700 C / 650 B

WEIGHT
700 C: 1917g / 650 B: 1769g

TUBELESS READY

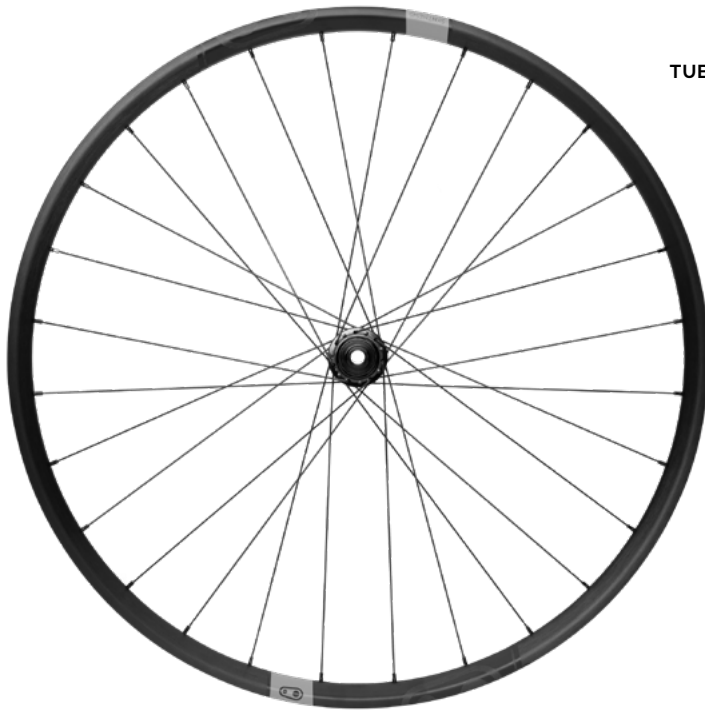

FRONT



REAR

FRONT WHEEL

SPOKE COUNT: 28
INNER RIM WIDTH: 26.5

REAR WHEEL

SPOKE COUNT: 28
INNER RIM WIDTH: 26.5

ARTICLE	UPC	NEW	MODEL	DIAMETER	HUB	DRIVER BODY	FRONT AXLE	REAR AXLE	RIM	WEIGHT	PRICE (€)
16831	641300168313	NEW		700c front	CB ratchet	-	12X100 mm	-	26.5mm	869g	240
16832	641300168320	NEW		700c rear	CB ratchet	XDR	-	142X12 mm	26.5mm	1050g	360
16833	641300168337	NEW	synthesis alloy gravel	700c rear	CB ratchet	HG	-	142X12 mm	26.5mm	1058g	360
16834	641300168344	NEW		650b front	CB ratchet	-	12X100 mm	-	26.5mm	792g	240
16835	641300168351	NEW		650b rear	CB ratchet	XDR	-	142X12 mm	26.5mm	977g	360
16836	641300168368	NEW		650b rear	CB ratchet	HG	-	142X12 mm	26.5mm	985g	360

PIÙ VELOCE PER UNA ACCELERAZIONE PIÙ RAPIDA PLUS RAPIDE POUR UNE PLUS FORTE ACCELERATION



BASSA INERZIA DI ROTAZIONE. Ruote dal design unico, la massa è distribuita più vicino al mozzo, così da garantire più velocità in accelerazione e decelerazione.

TUBELESS READY. Il cerchio hole-less è più forte e non ha bisogno del rim tape per il montaggio dei tubeless.

FAIBLE INERTIE DE ROTATION. Conception de roue unique, distribue la masse au plus prêt du moyeu augmentant la rapidité d'accélération et de décélération.

TUBELESS PRÊT. Pas de trous de jantes, augmentant ainsi la résistance et pas de fond de jante nécessaire pour le montage de pneus tubeless.

ROBUSTO E RIGIDO ROBUSTE ET PLUS RIGIDE

TECNOLOGIA RAGGI TWINPAIR. Progettata utilizzando la forma più resistente, il triangolo, per aumentare resistenza e rigidità.

MERAVIGLIOSAMENTE SEMPLICE. Raggi di un'unica lunghezza: facili da rimuovere e da sostituire senza dover togliere il copertone.

MONTAGE RAYONS "TWIN PAIR". Conçu en utilisant le montage rayons en triangle afin d'optimiser résistance et rigidité.

MERVEILLEUSEMENT SIMPLE. Une seule longueur de rayon facilitant le remplacement sans démonter le pneu.

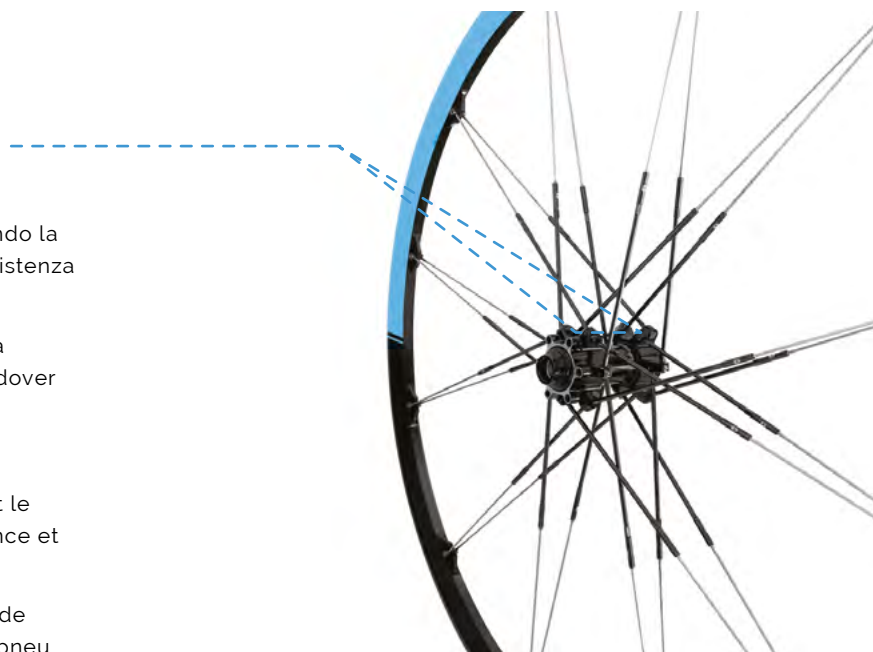

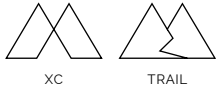

ALLOY WHEELSETS

COBALT

2 COBALT 2
ALUMINUM

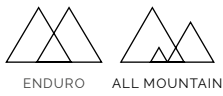
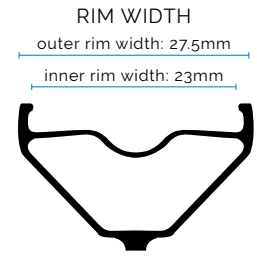

IODINE

2 IODINE 2
ALUMINUM

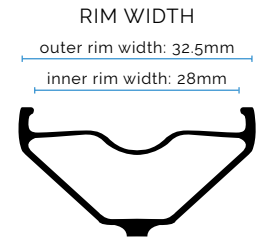

ZINC

3 ZINC 3
ALUMINUM

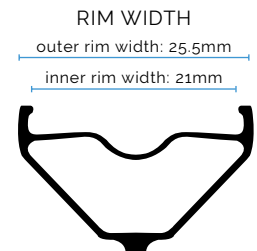

ARTICLE	UPC	MODEL	DIAMETER	HUB	DRIVER BODY	FRONT AXLE	REAR AXLE	COLOR	WEIGHT	PRICE (€)
16140	641300161406	cobalt 2	29"	standard	shimano hg	100x15 mm	142x12 mm	black/grey	1735g	600
16143	641300161437	iodine 2	29"	boost	-	110x15 mm	148x12 mm	black/grey	1900g	600
16145	641300161451		27.5"	boost	-	110x15 mm	148x12 mm	black/grey	1830g	600
16139	641300161390	zinc 3	29"	standard	shimano hg	100x15 mm	142x12 mm	black/white	1645g	800



GRIPS COBALT

COBALT
GRIPS

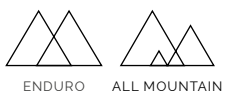

IODINE

IODINE
GRIP



ARTICLE	UPC	MODEL	COLOR	material	WIDTH	WEIGHT	PRICE (€)
15279	641300152794		silver				30
14918	641300149183	cobalt grips	gold	High density foam	130mm	67g	30
14919	641300149190		red				30
14920	641300149206	iodine grip	black	Krayton rubber	130mm	95g	30



WHEELSETS ACCESSORIES



XD DRIVER BODY
SYNTHESIS & ALLOY WHEELSETS



WHEEL END CAP KIT (FRONT)
COBALT / IODINE / ZINC
9mm



WHEEL END CAP + AXLE KIT (FRONT)
COBALT / IODINE / ZINC
100mm x 12mm



WHEEL END CAP KIT (FRONT)
COBALT / IODINE / ZINC
15mm



WHEEL END CAP KIT (REAR)
COBALT / IODINE (LEVEL 3 & 11)
135mm x 10mm



WHEEL END CAP KIT (REAR)
COBALT / IODINE (LEVEL 3 & 11)
142mm x 12mm

ARTICLE	UPC	COLLECTION	MODEL KIT	PRICE (€)
15538	641300155382	wheelsets accessories	wheel synthesis and alloy xd driver body for: level 2,3 e 11 (from range 2017)	100
99202	641300992024		wheel end cap kit for: cobalt / iodine / zinc > front 9mm	20
99203	641300992031		wheel end cap kit for: cobalt / iodine / zinc > front 15mm	20
99204	641300992048		wheel end cap kit for: cobalt / iodine level 3/11 > rear 135x10 mm	20
99205	641300992055		wheel end cap kit for: cobalt / iodine level 3/11 > rear 142x12 mm	20
99162	641300991621		wheel end cap + axle kit for: cobalt / iodine / zinc > front 100x12 mm	30



DROPPER SEATPOST

HIGHLINE DROPPER SEATPOST

IL NOSTRO REGGISSELLA TELESCOPICO CON PESO PIU' CONTENUTO,
GRAZIE AI SUOI MATERIALI PREMIUM CHE RISPARMIANO GRAMMI.

LA PLUS LÉGÈRE DE NOS TIGES DE SELLE RÉALISÉE À PARTIR DE MATÉRIAUX
DE HAUTE QUALITÉ POUR UN GAIN DE POIDS MAXIMUM.



DROPPER SEATPOST

HIGHLINE 11 DROPPER SEATPOST

GUARNIZIONI PREMIUM TRELLEBORG, ESCLUSIVI CUSCINETTI E CALOTTE IGUS, CAVO JAGWIRE & UNA CARTUCCIA IDRAULICA INDIPENDENTE CHE OFFRE QUALITÀ E AFFIDABILITÀ INDISCUSSE IN QUESTO SETTORE.

JOINT D'ÉTANCHÉITÉ PREMIUM TRELLEBORG, ROULEMENTS ET CLES EXCLUSIFS IGUS, TRANSMISSION JAGWIRE & ET UNE CARTOUCHE HYDRAULIQUE AUTONOME PROCURENT UNE QUALITÉ ET UNE FIABILITÉ DE POINTE.

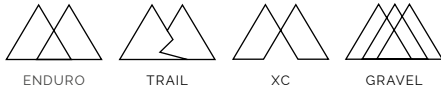

HIGHLINE 11
100mm
125mm
150mm
170mm

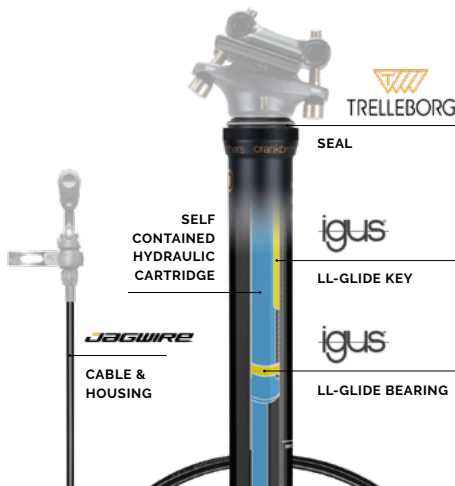

COMPONENTI PREMIUM

- cartuccia idraulica indipendente e proprietaria IFP sull'Highline 11, sviluppato da Crankbrothers per attuazioni estremamente fluide
- cuscinetti di scorrimento e calotte proprietarie Igus LL per ridurre ogni possibile gioco
- cavi e guaine Jagwire

COMPOSANTS PREMIUM

- cartouche hydraulique IFP autonome exclusive sur Highline 11 développée par CB pour un fonctionnement extrêmement doux
- roulements et clés exclusifs Igus LL-glide pour minimiser le jeu
- Câble et gaine Jagwire

QUICK-SADDLE INSTALLATION SYSTEM



CARATTERISTICHE DELLA TESTA

- testa in alluminio
- viti di montaggio in titanio
- morsetto a due viti per una facile installazione, regolazione in arretramento/avanzamento e inclinazione della sella
- 47 mm di stack minimo per un'escursione piena anche sulle bici più piccole

CARACTERISTIQUES DE LA TÊTE

- tête en aluminium
- visserie titane
- tête à dégagement rapide à 2 boulons pour faciliter le réglage de l'avancée ou le recul et l'inclinaison de la selle
- hauteur de la pile minimale de 47 mm procurant une course complète pour les vélos de petites tailles



LINEAR PULL CABLE

SISTEMA DI ATTUAZIONE

- il sistema di ingaggio lineare a connessione rapida garantisce un'installazione e un'instradamento facile dei cavi
- questa caratteristica consente un'azione più fluida e maggiore velocità di ritorno

ACTUATOR SYSTEM

- le mécanisme de traction linéaire à connexion rapide facilite l'installation et l'acheminement des cables.
- cette fonction permet une action plus souple et une vitesse de retour plus rapide

CARACTERISTIQUES

- disponibile in versione: 100mm/125mm/150mm/170mm + infiniti step intermedi di regolazione
- diametri: 30.9 & 31.6
- lunghezza porzione insertata: vedi tabella
- pesi: vedi tabella
- canotto in carbonio
- viti di montaggio in titanio
- 4 anni di garanzia

CARATTERISTICHE

- Disponible en version: 100mm/125mm/150mm/170mm avec des réglages de course multiples
- diamètres: 30.9 & 31.6
- longueurs d'insertion: voir tableau
- poids: voir tableau
- fourreau carbone
- visserie titane
- garantie de 4 ans

DROPPER SEATPOST

HIGHLINE 7 & 3 REGGISSELLA TELESCOPICO TIGE DE SELLE TÉLESCOPIQUE 7 & 3

GUARNIZIONI D'ALTA GAMMA TRELLEBORG, SCORRIMENTI E PARTI ESCLUSIVE IGUS, CABLAGGI JAGWIRE, CARTUCCIA IDRAULICA INDIPENDENTE E AFFIDABILE, PRODOTTA DA UN'AZIENDA LEADER.

JOINT D'ETANCHEITE PREMIUM TRELLEBORG, ROULEMENTS EXCLUSIFS IGUS, TRANSMISSION JAGWIRE, CARTOUCHE HYDRAULIQUE INDEPENDANTE, DE QUALITE ET FIABILITE PRODUITE PAR UNE FIRME A LA POINTE DE LA TECHNOLOGIE.



7

HIGHLINE 7
100mm
125mm
150mm
170mm
200mm

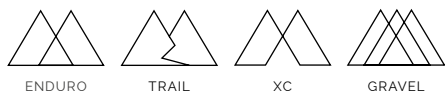

3

HIGHLINE 3
80mm
100mm
125mm
150mm
170mm
200mm





DROPPER SEATPOST

HIGHLINE XC/REGGISSELLA TELESCOPICO DA GRAVEL BIKE TIGE DE SELLE TÉLESCOPIQUE XC POUR VÉLO GRAVEL

UN REGGISSELLA TELESCOPICO CON SEZIONE RIDOTTA CHE OFFRE OPZIONI CONTENUTE DI ESCURSIONE ADATTE AL CROSS COUNTRY E AL GRAVEL BIKING.

UNE TIGE DE SELLE TÉLESCOPIQUE D'UN DIAMÈTRE RÉDUIT PARFAITEMENT ADAPTÉE POUR LA RANDONNÉE VTT ET GRAVEL.

HIGHLINE XC/GRAVEL Ø 27,2mm
60mm
80mm
100mm
125mm



HYDRAULIC IFP CARTRIDGE



QUICK-CONNECT LINEAR
PULL ACTUATOR



60mm MINIMUM STACK HEIGHT

CARATTERISTICHE

- disponibile in versione 60mm / 80mm / 100mm / 125mm
+ infiniti step intermedi di regolazione
- diametro: 27,2mm
- lunghezza della porzione insertata: 174mm corta & 264mm lunga / 264mm / 264mm / 264mm (dalla parte inferiore del collarino alla parte inferiore dell'attuatore)
- pesi: 369g & 410g / 434g / 459g / 467g
- il sistema di scorrimento lineare quick-connect facilita l'installazione e l'instradamento del cavo
- 60mm di stack minimo
- cartuccia idraulica IFP indipendente
- morsetto standard a due viti
- routing interno
- meccanismi interni premium
- cavo e guaina Jagwire®
- comando remoto venduto separatamente
- 4 anni di garanzia

CARACTERISTIQUES

- disponible en version 60mm / 80mm / 100mm / 125mm
avec des réglages de course multiples
- diamètre: 27,2mm
- longueurs d'insertion: 174mm au plus court et 264mm au plus long / 264mm / 264mm / 264mm (du bas du collier à la partie inférieure de l'actuateur)
- poids: 369g & 410g / 434g / 459g / 467g
- le mécanisme de traction linéaire à connexion rapide Quick-connect facilite la mise en place et le positionnement des câbles
- minimum 60mm de "stack"
- cartouche hydraulique IFP indépendante
- tête standard à deux vis
- routage interne
- mécanismes internes premium
- câble et gaine Jagwire®
- télécommande vendue séparément
- garantie de 4 ans

DROPPER SEATPOST



HIGHLINE 11							
ARTICLE	UPC	MODEL	TRAVEL	DIAMETER	LENGTH	WEIGHT*	PRICE (€)
16481	641300164810	highline 11* (No remote lever included)	100mm	30.9	367mm	398g	€ 400
16482	641300164827			31.6		418g	€ 400
16483	641300164834		125mm	30.9	417mm	429g	€ 400
16484	641300164841			31.6		449g	€ 400
16485	641300164858		150mm	30.9	467mm	465g	€ 400
16486	641300164865			31.6		486g	€ 400
16487	641300164872		170mm	30.9	507mm	488g	€ 400
16488	641300164889			31.6		509g	€ 400



HIGHLINE 7							
ARTICLE	UPC	MODEL	TRAVEL	DIAMETER	LENGTH	WEIGHT*	PRICE (€)
16378	641300163783	highline 7 (No remote lever included)	100mm	30.9	367mm	474g	300
16379	641300163790			31.6		490g	300
16380	641300163806		125mm	30.9	417mm	515g	300
16381	641300163813			31.6		525g	300
16382	641300163820		150mm	30.9	467mm	550g	300
16383	641300163837			31.6		572g	300
16384	641300163844		170mm	30.9	507mm	583g	300
16385	641300163851			31.6		604g	300
16621	641300166210	200mm	31.6	567mm	679g	300	

(*) Il peso include solo il reggisella. La guaina aggiunge tra i 20 e i 60 grammi in base alla lunghezza.

(*) Le poids comprend seulement la tige de selle. Le logement extérieur ajoute 25-60 g en fonction de la longueur.



DROPPER SEATPOST

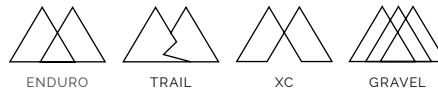

HIGHLINE 3							
ARTICLE	UPC	MODEL	TRAVEL	DIAMETER	LENGTH	WEIGHT*	PRICE (€)
16501	641300165015	highline 3 (No remote lever included)	80mm	30.9	418mm	540g	200
16502	641300165022			31.6		564g	200
16370	641300163707		100mm	30.9	370mm	484g	200
16371	641300163714			31.6		503g	200
16469	641300164698		34.9	603g	200		
16372	641300163721		125mm	30.9	421mm	525g	200
16373	641300163738			31.6		545g	200
16471	641300164711		34.9	645g	200		
16374	641300163745		150mm	30.9	469mm	565g	200
16375	641300163752			31.6		587g	200
16472	641300164728		34.9	699g	200		
16376	641300163769		170mm	30.9	509mm	585g	200
16377	641300163776			31.6		609g	200
16473	641300164735		34.9	735g	200		
16523	641300165237		200mm	31.6	569mm	686g	200

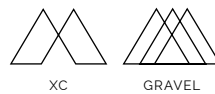

HIGHLINE XC/GRAVEL							
ARTICLE	UPC	MODEL	TRAVEL	DIAMETER	LENGTH	WEIGHT*	PRICE (€)
16489	641300164896	highline xc/gravel (No remote lever included)	60mm short	27.2	297mm	369g	250
16490	641300164902		60mm long	27.2	387mm	410g	250
16500	641300165008		80mm	27.2	407mm	434g	250
16468	641300164681		100mm	27.2	427mm	459g	250
16470	641300164704		125mm	27.2	452mm	467g	250

(*) Il peso include solo il reggisella. La guaina aggiunge tra i 20 e i 60 grammi in base alla lunghezza.

(*) Le poids comprend seulement la tige de selle. Le logement extérieur ajoute 25-60 g en fonction de la longueur.

HIGHLINE REMOTE KIT

IL CONTROLLO REMOTO PIÙ ERGONOMICO LA PLUS ERGONOMIQUE

IL CONTROLLO REMOTO DELL'HIGHLINE È CARATTERIZZATO DA UN SISTEMA DI REGOLAZIONE SFERICO, CON UNA CAPACITÀ DI ROTAZIONE QUASI COMPLETA E LA POSSIBILITÀ DI REGOLARE L'INCLINAZIONE PER UNA PERFETTA ERGONOMIA.

LA COMMANDE DE L'HIGHLINE SE CARACTÉRISE PAR UN SYSTÈME D'AJUSTEMENT SPHÉRIQUE UNIQUE EN SON GENRE. IDÉALE SUR LE PLAN ERGONOMIQUE, ELLE PERMET À CHAQUE PILOTE DE LA POSITIONNER SUR LE CINTRE À LA POSITION PARFAITE.



HIGHLINE EVO
FLATBAR DROPPER POST REMOTE KIT
MATCHMAKER



HIGHLINE EVO
FLATBAR DROPPER POST REMOTE KIT
22.2 CLAMP



HIGHLINE EVO
FLATBAR DROPPER POST REMOTE KIT
I-SPEC EV



HIGHLINE
FLATBAR DROPPER POST REMOTE KIT
22.2 CLAMP



HIGHLINE
DROPBAR DROPPER POST REMOTE KIT V2

ARTICLE	UPC	MODEL	PRICE (€)
16754	641300167545	highline EVO - flatbar dropper post remote kit 22.2 clamp	70
16755	641300167552	highline EVO - flatbar dropper post remote kit matchmaker	70
16756	641300167569	highline EVO - flatbar dropper post remote kit I-Spec EV	70
16066	641300160669	highline remote kit 22.2 clamp	60
16824	641300168245	highline dropbar remote kit V2	50



CIGAR TOOL

KIT COMPATTO DI RIPARAZIONE TUBELESS CON ADATTATORE PER LA CARTUCCIA DI CO2
KIT COMPACT DE REPARATION POUR TUBELESS COMPRENANT L'ADAPTATEUR CO2

PLUG KIT + CO2 HEAD

MOUNTING BRACKET

supporto porta borraccia per fissare il kit sul telaio

support porte bidon pour fixer le kit sur le cadre du vélo

Co2 HEAD

Il connettore Klic (solo per valvole presta) consente l'uso di cartucce di Co2

L'adaptateur de cartouche klic Co2 (presta uniquement) permet l'utilisation de la cartouche Co2

Cartuccia di Co2 venduta separatamente
Cartouche de Co2 vendue séparément



STORAGE CASE

Custodia in alluminio con tappo superiore filettato per l'inserimento della cartuccia di CO2

Boitier de rangement en aluminium avec bouchon supérieur fileté pour cartouche Co2

TIRE PLUG TOOL

L'utensile si avvita nel cappuccio della custodia, funzionando da maniglia

L'outil se visse dans le capuchon du boitier servant aussi de poignée.

CARATTERISTICHE

- utensile per sigillare lo pneumatico
- 5 pezzi
- adattatore cartuccia Co2
- custodia
- supporto di montaggio
- 5 anni di garanzia
- peso 55g

CARACTERISTIQUES

- Outil pour obturer le pneu
- Bouchons de pneu (5)
- Adaptateur de cartouche de Co2
- Casier de rangement
- Support de montage
- Garantie 5 ans
- Poids 55g

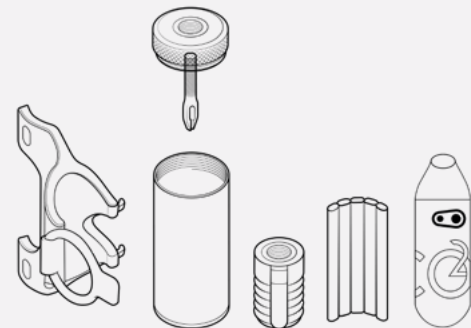

ARTICLE	UPC	MODEL	COLOR	WEIGHT	PRICE (€)
16570	641300165701	tool cigar	black/silver	55g	30
16637	641300166371	tire plug refill kit (10 pieces)	-	-	5

TOOLS

NEW

S.O.S TT17 TWIN TUBE KIT SOS TOOLS

- Chiavi esagonali da 2, 2.5, 3, 4, 5, 6, 8mm
 - Chiave a stella T25 Torx
 - Cacciavite piatto
 - Attrezzo per riparazione pneumatico + 2 plug
 - Cacciagomme
 - Attrezzo per catena
 - Chiavi per raggi 0, 1, 2
 - Attrezzo per valvola
 - Valvola per bombole CO2
 - Tubo per trasporto
 - Peso: 247g
 - Adatto anche per un anello di catena di ricambio + bombolette CO2 da 16/20g, vendute separatamente
- 2, 2.5, 3, 4, 5, 6, 8mm hexagonal
 - Outil torx T25
 - Tournevis plat
 - Outil pour reboucher les pneus + 2 bouchons
 - Démonte-pneu
 - Outil de chaîne
 - Clé à rayons 0, 1, 2
 - Outil de valve
 - Embout CO2
 - Tube de stockage
 - 247g
 - Contient un maillon de chaîne de rechange + 16/20g de CO2, vendus séparément



S.O.S BC18 BOTTLE CAGE KIT SOS TOOLS

- Portaborraccia con ingresso reversibile sinistro/destro
 - Chiavi esagonali da 2, 2.5, 3, 4, 5, 6, 8mm
 - Chiavi torx T10 e T25
 - Cacciavite piatto
 - Strumento per riparazione pneumatici + 4 plug
 - Cacciagomme
 - Strumento per catena
 - Chiavi per raggi 0, 1, 2
 - Strumento per valvola
 - Valvola per cartucce CO2
 - Peso: 247g
 - Adatto per contenere un collegamento catena di scorta + cartucce CO2 da 16/20/25g o la pompa Crankbrothers Klic HV (venduti separatamente)
 - Larghezza ottimizzata per una massima libertà di pedalata
- Entrée du bidon réversible gauche/droite conception de la cage
 - Outils 2, 2.5, 3, 4, 5, 6, 8mm hex
 - Outils T10, T25 torx
 - Tournevis plat
 - Outil pour mèches de pneus + 4x mèches
 - Démonte-pneu
 - Dérive chaîne
 - Clé à rayons 0, 1, 2
 - Extracteur de valve
 - Tête CO2
 - 247g
 - Contient un maillon de chaîne de rechange + 16/20/25g CO2 ou pompe Crankbrothers Klic HV, vendue séparément
 - Largeur optimisée pour un maximum de dégagement au pédalage



S.O.S BC2 BOTTLE CAGE + SOS TOOLS

- Design del portaborraccia con ingresso reversibile sinistro/destro
 - Attrezzo per riparazione pneumatico + 2 plug
 - Cacciagomme
 - Peso: 73g
- Entrée réversible du bidon gauche/droite conception de la cage
 - Outil pour reboucher les pneus + 2 bouchons
 - Démonte-pneu
 - 73g





TOOLS

NEW

S.O.S TS2 TUBE STASH + SOS TOOLS

- Trasporto di una camera d'aria/ materiale con una cinghia in velcro
- Attrezzo per riparazione pneumatico + 2 plug
- Cacciagomme
- Peso: 53g
- Rangement chambre à air et du matériel avec sangle auto-agrippante
- Outil pour reboucher les pneus + 2 bouchons
- Démonte-pneu
- 53g



S.O.S TS18 TUBE STASH KIT SOS TOOLS

- Spazio per una camera d'aria/ materiale con cinghia in velcro
- Chiavi esagonali da 2, 2.5, 3, 4, 5, 6, 8mm
- Chiavi a stella T10, T25 Torx
- Cacciavite piatto
- Attrezzo per riparazione pneumatico + 4 plug
- Cacciagomme
- Attrezzo per catena
- Chiavi per raggi 0, 1, 2
- Attrezzo per valvola
- Valvola per bombole CO2
- Peso: 229g
- Adatto per un anello di catena di ricambio + bombole CO2 da 16/20/25g o pompa Crankbrothers Klic HV, vendute separatamente
- Larghezza ottimizzata per la massima libertà di pedalata
- Rangement chambre à air et du matériel avec sangle auto-agrippante
- 2, 2.5, 3, 4, 5, 6, 8mm hexagonal
- Outils torx T10, T25
- Tournevis plat
- Outil pour reboucher les pneus + 4 bouchons
- Démonte-pneu
- Outil de chaîne
- Clés à rayons 0, 1, 2
- Outil de valve
- Embout CO2
- 229g
- Contient un maillon de chaîne de rechange + 16/20/25g CO2 ou pompe Crankbrothers Klic HV, vendue séparément
- Largeur optimisée pour un dégagement de pédalage maximal



ARTICLE	UPC	NEW	MODEL	PRICE (€)
16774	641300167743	NEW	tool S.O.S. TT17 twin tube tool kit	120
16776	641300167767	NEW	tool S.O.S. BC18 bottle cage kit	100
16775	641300167750	NEW	tool S.O.S. BC2 bottle cage +	40
16777	641300167774	NEW	tool S.O.S. TS2 tube stash +	30
16778	641300167781	NEW	tool S.O.S. TS18 tube stash tool kit	90

TOOLS

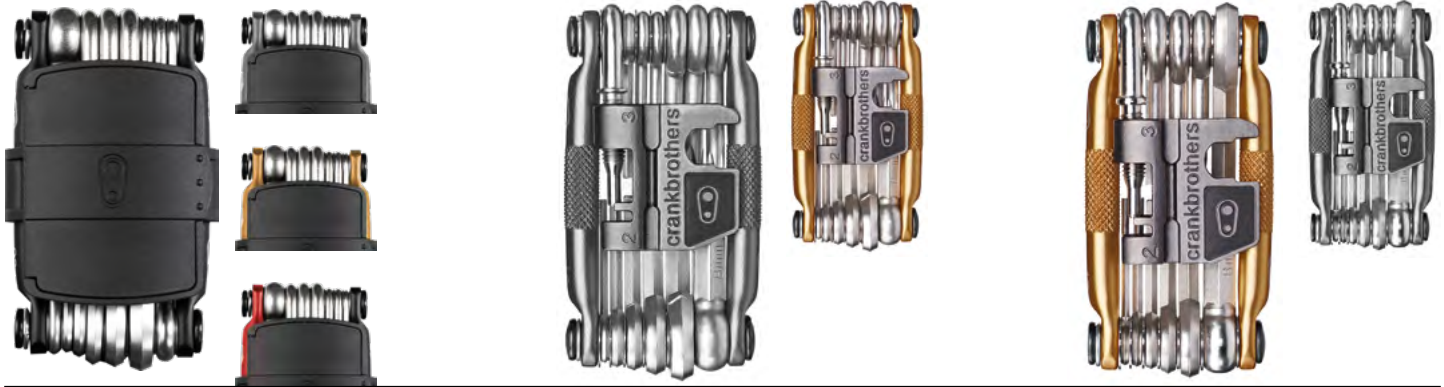

M20

M19

M17



M17 - SPLATTER EDITION

M13

M10

M5

ARTICLE	UPC	MODEL	COLOR	WEIGHT	PRICE (€)
16403	641300164032	multi 20	matte black	203g	40
16402	641300164025		nickel		40
16405	641300164056		gold		40
16404	641300164049		matte black/red		40
11465	641300352194	multi 19	nickel	175g	37
10758	641300351197		gold		37
10752	641300350176	multi 17	nickel	168g	30
10755	641300351173		gold		30
16679	641300166791		multi 17 splatter edition		red*
16681	641300166814		green*	168g	30
16682	641300166821		blue*	30	30
16399	641300163998	multi 13	matte black	164g	27
16398	641300163981		nickel		27
16401	641300164018		gold		27
16400	641300164001		matte black/red		27
10747	641300350107	multi 10	nickel	124g	20
10750	641300351104		gold		20
10743	641300350053	multi 5	nickel	85g	15
10745	641300351050		gold		15

(*) Fino ad esaurimento scorte | Jusqu'à épuisement des stocks



TOOLS



F16

F11

F15

F10+

TOOL BITS

	HEX 2	HEX 2.5	HEX 3	HEX 4	HEX 5	HEX 6	HEX 8	PHIL #1	PHIL #2	FLAT	TORX 10	TORX 25	OPEN WRENCH 8MM	OPEN WRENCH 10MM	ROTOR ALIGNMENT	CHAIN TOOL	SPOKE WRENCH	VALVE CORE TOOL	TIRE PLUG TECH	
M5 85g			●	●	●	●			●											
M10 150g	●	●	●	●	●	●	●		●	●		●								
M13 164g	●	●	●	●	●	●	●	●	●	●	●	●						●	●	
M17 168g	●	●	●	●	●	●	●		●	●		●	●	●		●	●			
M19 175g	●	●	●	●	●	●	●	●	●	●	●	●	●	●		●	●			
M20 203g	●	●	●	●	●	●	●	●	●	●	●	●	●		●	●	●	●	●	●
F10 116g	●	●	●	●	●	●	●		●	●		●								
F11 131g	●	●	●	●	●	●	●		●	●		●								●
F15 164g	●	●	●	●	●	●	●		●	●		●				●	●			
F16 179g	●	●	●	●	●	●	●		●	●		●				●	●			●

ARTICLE	UPC	MODEL	COLOR	WEIGHT	PRICE (€)
16753	641300167538	f16	black	179g	60
16092	641300160928	f15	black/silver	169g	50
16752	641300167521	f11	black	131g	50
16091	641300160911	f10+	black/silver	121g	40



PUMPS & CO₂

THE WORKSHOP ESSENTIAL



FLOOR PUMPS

POMPA A TERRA KLIC | POMPES A PIEDS KLIC

- Testa magnetica
- Manichetta integrata nel corpo della pompa
- Manometro veloce da installare
- Manichetta fermata magneticamente al corpo della pompa
- Treppiede per maggiore stabilità
- 160 psi / 11 bar
- Serbatoio removibile
- Il serbatoio può essere rimosso per montare facilmente tubeless
- Il serbatoio può essere trasportato facilmente
- Testa universale presta/schrader
- Manometro intuitivo

- Tête magnétique
- Embout logé dans le corps de la pompe
- Rapidité d'installation du manomètre
- Embout fixé magnétiquement sur le corps de la pompe
- Trépied assurant une stabilité parfaite
- 160 psi / 11 bar
- Réservoir amovible
- Le réservoir peut être chargé pour monter et gonfler les pneus tubeless
- Le réservoir est amovible pour transporter facilement séparément si désiré
- Tête universelle Presta/Schrader
- Manomètre



SERBATOIO REMOVIBILE

Installa e gonfia coperture tubeless con facilità.

RÉSERVOIR AMOVIBLE

Montage et gonflage des pneus tubeless aisé.



TUBO NASCOSTO

Viene riposta ordinatamente quando non utilizzata.

TUYAU FLEXIBLE INTÉGRÉ

Rangement pratique des éléments dans le corps de la pompe, après utilisation.



CONNESSIONE MAGNETICA VELOCE

Interfaccia facile per il beccuccio e per il serbatoio.

CONNECTION MAGNÉTIQUE ULTRA RAPIDE

Interface tuyau flexible/réservoir facile.

BECCUCCIO UNIVERSALE PER VALVOLE PRESTA / SCHRADER (SOLO CORPI VALVOLA PRESTA TUTTI FILETTATI)

TÊTE UNIVERSELLE POUR PRESTA / SCHRADER (CORPS DE VALVE PRESTA ENTièrement FILETÉS UNIQUEMENT)



ARTICLE	UPC	MODEL	COLOR	PSI / BAR	PRICE (€)
16197	641300161970	klic w/ digital gauge + canister	silver	160 psi / 11 bar	250
16198	641300161987	klic w/ analog gauge + canister	silver	160 psi / 11 bar	220

FLOOR PUMPS

POMPA A TERRA STERLING | POMPES A PIEDS STERLING

- Interruttore alta pressione/alto volume attivabile con il piede
 - Base in alluminio per stabilità e leggerezza
 - Corpo e base in alluminio resistenti alla corrosione
 - Testa intelligente: presta & schrader ready
 - Manometro bar/psi
-
- Activation par pied de l'interrupteur haute pression/haut volume
 - Base aluminium, légère et stable
 - Corps et base aluminium, robuste et résistant à la corrosion
 - Tête compatible Presta et Schrader
 - Manomètre bar/psi



POMPA A TERRA SAPPHIRE
POMPES A PIEDS SAPPHIRE



POMPA A TERRA GEM
POMPES A PIEDS GEM



ARTICLE	UPC	MODEL	COLOR	PSI / BAR	HEAD	BASE	PRICE (€)
16168	641300161680	sterling	silver	160 psi / 11 bar	universal presta / schrader	alloy	80
16303	641300163035	sapphire	black	160 psi / 11 bar	universal presta / schrader	steel	60
16218	641300162182		black				60
16205	641300162052	gem	red	160 psi / 11 bar	2 stage presta / schrader	steel	60
16206	641300162069		green				60



CO₂

CO₂ CARTRIDGE



ARTICLE	UPC	MODEL	WEIGHT	DESCRIPTION	PRICE (€)
16235	641300162359		co2 25g cartridge	20 units bulk pack	121
16232	641300162328	co2 cartridge	co2 25g cartridge	(2 units) w/ inflator	20
16230	64130016230		co2 16g cartridge	(2 units) w/ inflator	16

HAND PUMPS

POMPE A MANO KLIC | POMPE A MAIN KLIC

- Manichetta flessibile integrata
- Testa magnetica con collarino orientabile per evitare allo sporco di penetrare
- Manichetta magnetica per installare velocemente la testa
- Testa intelligente presta e schrader ready
- Maniglia pieghevole e bloccabile
- Manometro incorporato in alcuni modelli
- Adattatore CO2 integrato in alcuni modelli
- Adattore per il montaggio sul telaio compreso su tutti i modelli
- 5 Anni di garanzia

- Raccord de pompe flexible logé dans le corps (sur tous les modèles)
- Tête magnétique orientable évitant la pénétration de saletés
- Rapidité et facilité d'installation du raccord de pompe grâce à son extrémité magnétique
- Compatible Presta / Schrader
- Poignée de pliage et de verrouillage sur tous les modèles
- Manomètre incorporé sur certains modèles
- Adaptateur CO2 incorporé dans la poignée, sur certains modèles
- Toutes le pompes sont livrées avec support de fixation au cadre
- Garantie 5 ans



PRESTA / SCHRADER READY

Svita e inverte la testa per passare da Presta a Schrader.

PRESTA / SCHRADER READY

Dévisser la tête pour basculer entre Presta et Schrader.



MANOMETRO

Preciso e facile da leggere.

MANOMÈTRES

Jauge très précise et facile à lire.



TESTA MAGNETICA ORIENTABILE

Testa magnetica orientabile a 360 gradi per evitare allo sporco di penetrare. Manichetta magnetica per installare la testa velocemente.

TÊTE MAGNETIQUE ORIENTABLE

Tête magnétique orientable à 360° évitant la pénétration de saletés. Extrémité du raccord magnétique permettant un montage rapide et facile sur la tête.



MANICHETTA FLESSIBILE/MANIGLIA BLOCCABILE /ADATTATORE CO2

La maniglia pieghevole permette di estrarre la manichetta. La testa magnetica con collarino orientabile per evitare allo sporco di penetrare. Adattatore CO2 integrato in alcuni modelli.

RACCORD FLEXIBLE ET ADAPTATEUR CO2 INCORPORE DANS LA POIGNE

Déverrouillage de la poignée pliable pour extraire le raccord. Tête magnétique orientable évitant la pénétration de saletés. Adaptateur CO2 intégré sur certains modèles.



HAND PUMPS

KLIC HP

ROAD SPECIFIC HIGH PRESSURE: 120 PSI / 8.3 BAR



KLIC HV

MTB SPECIFIC HIGH VOLUME: 110 PSI / 7.6 BAR



POMPE A MANO GEM | POMPE A MAIN GEM

130+ PSI / 9+ BAR

- Pompa premium, con adattatore alta pressione/alto volume brevettato per un gonfiaggio facilitato.
- Testa intelligente che si adatta automaticamente alla valvola presta o schrader.
- Disponibile in due lunghezze, con o senza manometro.
- Pompes premium avec interrupteur haute pression/haut volume breveté, pour un gonflage facile.
- Embout compatible pour adaptation sur valve Presta ou Schrader.
- Disponible en deux longueurs, avec ou sans manomètre.



ARTICLE	UPC	MODEL	DESCRIPTION	COLOR	LENGTH	WEIGHT	PRICE (€)
16116	641300161161		klic hp gauge w/ co2		260mm	142g	60
16114	641300161147	klic hp	klic hp gauge	silver	260mm	132g	50
16112	641300161123		klic hp		260mm	102g	40
16117	641300161178		klic hv gauge w/ co2		260mm	145g	60
16115	641300161154	klic hv	klic hv gauge	silver	260mm	135g	50
16113	641300161130		klic hv		260mm	105g	40
14683	641300146830			red			25
14685	641300146854	gem S	-	green	176mm	131g	25
14681	641300146816			silver			25

Continental 
The Future in Motion



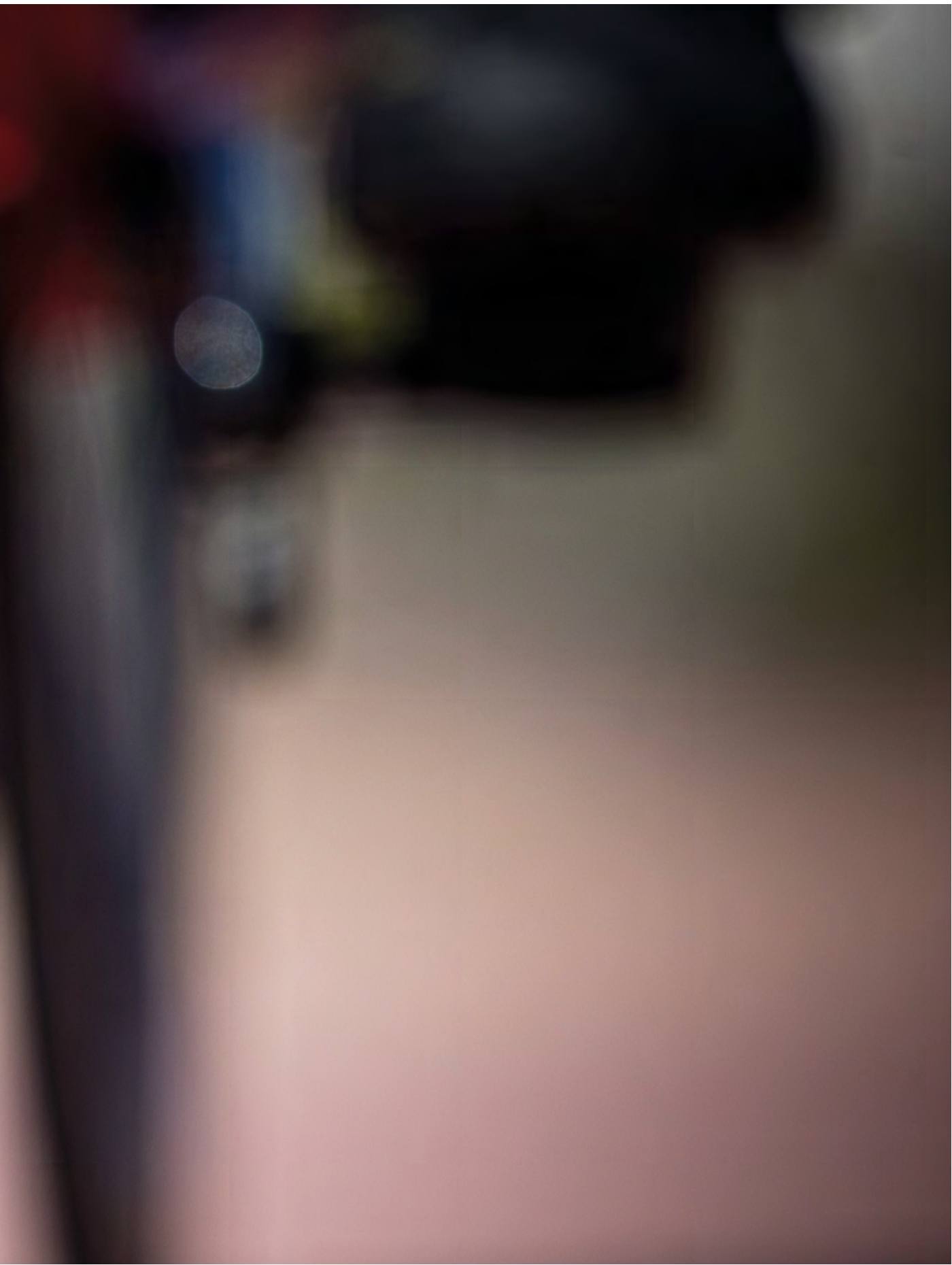

MADE IN GERMANY



PASSIONE E TECNOLOGIA

Produrre i migliori pneumatici è il nostro imperativo. Per questo i nostri designer ed ingegneri sono sempre impegnati a rendere i nostri prodotti più efficienti, ad esempio sviluppando o migliorando formulazioni per le nostre mescole. Queste innovazioni spesso non sono evidenti a prima vista, ma sono decisamente rimarchevoli. Pedala la differenza, pedala il "Made in Germany".

Continental, l'unico produttore di pneumatici da ciclismo in Germania. "Handmade in Germany" significa che gli pneumatici sono prodotti nel nostro stabilimento di Korbach, la maggior parte a mano e con un'alta proporzione di lavoro manuale, dal design della gomma al controllo di qualità finale. Per te questo significa offrire ai tuoi clienti pneumatici con tecnologia tedesca, così come accade dal 1871.

PASSION ET TECHNOLOGIE

Notre objectif: produire les meilleurs pneus au monde. C'est la raison pour laquelle nos designers et ingénieurs travaillent en permanence à l'amélioration de nos produits, développant par exemple régulièrement de nouveaux mélanges de gomme ou améliorant les formules existantes. Si ces changements ne sont pas toujours visibles au premier coup d'œil, vous les remarquerez à l'usage sans aucun doute! Sentez la différence, appréciez le fait main "Made in Germany".

Continental est le seul producteur allemand de pneus pour cyclistes en Allemagne. La mention "handmade in Germany" indique que les pneus sont produits dans notre usine de Korbach, principalement à la main et avec une forte proportion de travail manuel, du design du pneu jusqu'au contrôle qualité final. Pour vous, cela signifie que vous allez offrir à vos clients des pneus de technologie allemande - une tradition depuis 1871.



PASSIONE E PRECISIONE

Solo i materiali di altissima qualità sono usati per produrre i nostri tubolari. I singoli elementi sono combinati e uniti con precisione. I ciclisti più famosi al mondo mettono tutta la loro fiducia nel nostro lavoro. Che sia strada o pista, i tubolari prodotti da Continental hanno lasciato il loro segno nelle competizioni in giro per il mondo.

- Undici dei dodici pneumatici prodotti nel nostro stabilimento di Korbach sono fatti a mano
- La camera d'aria è cucita direttamente sulla carcassa con circa 400 punti
- Tecnologia tedesca che coinvolge tutta la struttura e la costruzione dello pneumatico
- Conformi al 100 % ai controlli di qualità

VANTAGGI

Leggero: peso inferiore di uno pneumatico copertoncino.

Veloce: alte velocità grazie alla bassa resistenza al rotolamento.

Adattabilità: può essere utilizzato con alte pressioni di esercizio.

Sicuro: nel caso di foratura durante l'utilizzo lo pneumatico non uscirà dalla gola del cerchio: perfetto per la competizione. Chiedilo ai professionisti!

PRÉCISION ET PASSION

Nous n'utilisons que des matières premières de qualité supérieure pour fabriquer nos boyaux. Les divers éléments sont ensuite assemblés entre eux avec le plus grand soin. Les meilleurs cyclistes nous font confiance: que ce soit sur route ou sur piste, les boyaux Continental ont laissé leur empreinte dans les compétitions à travers le monde.

- Onze des douze pneus que nous produisons dans notre usine de Korbach sont fabriqués à la main
- La chambre à air est cousue directement sur la carcasse par environ 400 points de couture
- Technologie Made in Germany
- Respect à 100 % des normes de contrôle qualité

AVANTAGES

Légèreté: Poids inférieur à un pneu pliable.

Rapide: Vitesse élevée grâce à une faible résistance au roulement.

Adaptabilité: Peut supporter une pression élevée.

Sûr: En cas de crevaison en roulant, le pneu ne déjante pas: parfait pour la compétition. Plébiscité par les coureurs professionnels!

ROAD





Grand Prix 5000 [Clincher]

È IL TUO MOMENTO! La nuova era nel ciclismo: il miglior allrounder del settore, portato ad un livello di prestazioni completamente nuovo!

C'EST VOTRE TEMPS! La nouvelle ère du cyclisme - Le meilleur acteur sur le terrain, permet d'atteindre le plus haut niveau de performance!



Lazer Grip, per renderti un tutt'uno con la strada. La scolpitura micropuntinata si estende fin sulle spalle dello pneumatico, per ottenere un'eccezionale tenuta in curva.

Lazer Grip, pour ne faire qu'un avec la route. La structure sculptée en micro pointe sur la partie haute des flancs procure une adhérence parfaite en courbe.



Tecnologia Active Comfort. Approccio rivoluzionario nel ciclismo. Incorporata nella costruzione dello pneumatico, la tecnologia Active Comfort smorza le vibrazioni e rende più confortevole la vostra guida.

Technologie Active Comfort. L'approche révolutionnaire du cyclisme. Intégrée à la construction du pneu, la technologie Active Comfort absorbe les vibrations et rend votre conduite plus souple.

ARTICLE	EAN	ETRTO	DIMENSION	COLOR/SIDEWALL	TECHNOLOGY	WEIGHT	BAR	MAX.BAR	PRICE (€)
Grand Prix 5000									
C0101624	4019238007824	25-622	28"1700x25 C	black/black skin foldable	Vectran B./LazerGrip/ACT	215g	6,50	8,50	74,99
C0101895	4019238056235	25-622	28"1700x25 C	black/transparent fold.	Vectran B./LazerGrip/ACT	225g	6,50	8,50	74,99
C0101947	4019238 064711	25-622	28"1700x25C	black/cream foldable	Vectran B./LazerGrip/ACT	260g	6,50	8,50	74,99
C0101625	4019238007848	28-622	28"1700x28 C	black/black skin foldable	Vectran B./LazerGrip/ACT	235g	6,50	8,00	74,99
C0101896	4019238056242	28-622	28"1700x28 C	black/transparent fold.	Vectran B./LazerGrip/ACT	235g	6,50	8,50	74,99
C0101948	4019238 064728	28-622	28"1700x28C	black/cream foldable	Vectran B./LazerGrip/ACT	290g	6,50	8,00	74,99
C0101813	4019238041972	30-622	28"1700x30 C	black/black skin foldable	Vectran B./LazerGrip/ACT	260g	6,00	7,00	74,99
C0101626	4019238007855	32-622	28"1700x32 C	black/black skin foldable	Vectran B./LazerGrip/ACT	290g	6,00	7,00	74,99



Grand Prix 5000 S Tubeless [Tubeless]

VERSIONE TUBELESS. Il nuovo Grand Prix 5000 S Tubeless Ready: più leggero, più veloce e con fianchi più resistenti. Il nuovo standard della tecnologia tubeless ready su strada. Più velocità, più comfort e una maggiore protezione dalle forature per le tue uscite in bici. Fatto per migliorare le tue prestazioni.

VERSION TUBELESS. Le nouveau Grand Prix 5000 S Tubeless Ready : Plus léger, plus rapide et avec des flancs plus résistants. La nouvelle norme en matière de technologie Tubeless Ready pour la route. Roulez plus vite, plus confortablement et avec une protection accrue contre les crevaisons. Conçu pour vous rendre meilleur.



Lazer Grip, per renderti un tutt'uno con la strada. La scolpitura micropuntinata si estende fin sulle spalle dello pneumatico, per ottenere un'eccezionale tenuta in curva.

Lazer Grip, pour ne faire qu'un avec la route. La structure sculptée en micro pointe sur la partie haute des flancs procure une adhérence parfaite en courbe.



Tecnologia Active Comfort. Approccio rivoluzionario nel ciclismo. Incorporata nella costruzione dello pneumatico, la tecnologia Active Comfort smorza le vibrazioni e rende più confortevole la vostra guida.

Tecnologie Active Comfort. L'approche révolutionnaire du cyclisme. Intégrée à la construction du pneu, la technologie Active Comfort absorbe les vibrations et rend votre conduite plus souple.



Tallone tubeless ready. Sviluppato specificamente, il tallone tubeless sigilla il cerchio grazie alla sua forma unica e fornisce un montaggio stabile nella gola.

Tubeless Ready Bead. Spécialement étudiée, la forme unique des talons du pneu permet un ajustement parfait et stable sur la gorge de la jante.

ARTICLE	EAN	ETRTO	DIMENSION	COLOR/SIDEWALL	TECHNOLOGY	WEIGHT	BAR	MAX.BAR	PRICE (€)
Grand Prix 5000 S Tubeless									
C0101866	4019238054439	25-622	28"1700x25C	black/black skin fold.	Vectran B./LazerGrip/ACT	245g	5,0	7,5	87,99
C0101873	4019238055559	25-622	28"1700x25C	black/transparent fold.	Vectran B./LazerGrip/ACT	295g	5,0	7,5	87,99
C0101867	4019238054422	28-622	28"1700x28C	black/black skin fold.	Vectran B./LazerGrip/ACT	270g	5,0	6,5	87,99
C0101874	4019238055580	28-622	28"1700x28C	black/transparent fold.	Vectran B./LazerGrip/ACT	315g	5,0	6,5	87,99
C0101869	4019238054408	32-622	28"1700x32C	black/black skin fold.	Vectran B./LazerGrip/ACT	320g	3,5	5,0	87,99
C0101876	4019238055641	32-622	28"1700x32C	black/transparent fold.	Vectran B./LazerGrip/ACT	375g	3,5	5,0	87,99



Grand Prix 5000 AllSeason TR

PER IL CHILOMETRO IN PIÙ. Il più resistente Grand Prix 5000: dà fiducia in tutte le condizioni meteorologiche e aumenta la tua sicurezza.

POUR L'EXTRA MILE. Le plus puissant Grand Prix 5000 : crée la confiance par tous les temps et renforce votre protection.



Lazer Grip, per renderti un tutt'uno con la strada. La scolpitura micropuntinata si estende fin sulle spalle dello pneumatico, per ottenere un'eccezionale tenuta in curva.

Lazer Grip, pour ne faire qu'un avec la route. La structure sculptée en micro pointe sur la partie haute des flancs procure une adhérence parfaite en courbe.



Tecnologia Active Comfort. Approccio rivoluzionario nel ciclismo. Incorporata nella costruzione dello pneumatico, la tecnologia Active Comfort smorza le vibrazioni e rende più confortevole la vostra guida.

Technologie Active Comfort. L'approche révolutionnaire du cyclisme. Intégrée à la construction du pneu, la technologie Active Comfort absorbe les vibrations et rend votre conduite plus souple.



Tallone tubeless ready. Sviluppato specificamente, il tallone tubeless sigilla il cerchio grazie alla sua forma unica e fornisce un montaggio stabile nella gola.

Tubeless Ready Bead. Spécialement étudiée, la forme unique des talons du pneu permet un ajustement parfait et stable sur la gorge de la jante.

ARTICLE	EAN	ETRTO	DIMENSION	COLOR/SIDEWALL	TECHNOLOGY	WEIGHT	BAR	MAX.BAR	PRICE (€)
Grand Prix 5000 AllSeason TR									
C0101910	4019238056754	25-622	28" 700x25 C	black/black reflex skin fold.	Vectran B./LazerGrip	250g	5,0	7,5	104,99
C0101911	4019238056815	28-622	28" 700x28 C	black/black reflex skin fold.	Vectran B./LazerGrip	280g	5,2	6,5	104,99
C0101912	4019238056914	32-622	28" 700x32 C	black/black reflex skin fold.	Vectran B./LazerGrip	325g	3,5	5,0	104,99
C0101913	4019238056990	35-622	28" 700x35 C	black/black reflex skin fold.	Vectran B./LazerGrip	325g	2,5	4,5	104,99
C0101901	4019238056716	25-622	28" 700x25 C	black/cream reflex skin fold.	Vectran B./LazerGrip	250g	5,1	7,5	99,99
C0101902	4019238056792	28-622	28" 700x28 C	black/cream reflex skin fold.	Vectran B./LazerGrip	280g	5,3	6,5	99,99
C0101903	4019238056884	32-622	28" 700x32 C	black/cream reflex skin fold.	Vectran B./LazerGrip	315g	3,5	5,1	99,99
C0101904	4019238056952	35-622	28" 700x35 C	black/cream reflex skin fold.	Vectran B./LazerGrip	315g	2,5	4,5	99,99



Grand Prix 4-Season

PRONTO PER OGNI STAGIONE. L'elevata protezione dalle forature e la lunga durata caratterizzano il Grand Prix 4-Season. Oltre che per durezza questo pneumatico si impone per un'ottima aderenza. Che si trovi in una competizione piuttosto che in un tour, chi lo usa beneficia della grande resistenza del tessuto DuraSkin della carcassa, un compagno affidabile per il ciclista assiduo.

ÉQUIPÉ POUR TOUTES LES SAISONS. Le Grand Prix 4-Season étonne par sa résistance aux contraintes extrêmes et ses performances kilométriques élevées. Il offre également une excellente adhérence sur le mouillé et en conditions hivernales à basse température. Sa double protection Vectran™ et son renfort de carcasse DuraSkin® vous met à l'abri des crevaisons et coupures. Un pneu excellent pour les grandes randos comme pour la compétition et pas uniquement en hiver!

Grand Prix

ALL-ROUNDER CONFORTEVOLE. Grand Prix è un classico all-rounder con un battistrada dal design moderno. È destinato alle biciclette da passeggio e da città. Offre una combinazione perfetta tra protezione dalle forature, comfort e scorrevolezza. Caratterizzato da una durata molto elevata, rende ogni tour un piacere puro. Uno strumento polivalente, con tante qualità.

POLYVALENCE ET CONFORT. Le Grand Prix est un classique synonyme de qualité et de performance. Il apporte une symbiose incontestable entre protection anti-crevaison, résistance à l'usure, performance et adhérence. Le profil moderne et le témoin d'usure complètent ses atouts. Un pneu très qualitatif qui apporte beaucoup de plaisir en randonnée.



ARTICLE	EAN	ETRTO	DIMENSION	COLOR/SIDEWALL	TECHNOLOGY	WEIGHT	BAR	MAX.BAR	PRICE (€)
Grand Prix 4-Season									
C0100175	4019238409116	25-622	700x25 C	black DuraSkin fold.	Double Vectran Breaker	230g	6,5	8,5	74,99
C0101105	4019238674620	28-622	700x28 C	black DuraSkin fold.	Double Vectran Breaker	295g	6,5	8,0	74,99
C0101095	4019238668131	32-622	700x32 C	black DuraSkin fold.	Double Vectran Breaker	340g	6,0	7,0	74,99
Grand Prix									
C0100506	4019238564617	23-622	700x23 C	black foldable	PolyX Breaker	225g	7,5	8,5	49,99
C0100637	4019238581409	25-622	700x25 C	black foldable	PolyX Breaker	230g	7,5	8,5	49,99
C0101109	4019238674590	28-622	700x28 C	black foldable	PolyX Breaker	275g	6,5	8,0	49,99



Grand Sport Race

ALL-ROUNDER NEL SEGMENTO PERFORMANCE. Lo pneumatico Grand Sport Race ti porta al massimo rendimento. La combinazione perfetta di elevata protezione dalle forature, alto comfort e scorrevolezza lo rendono ideale per le competizioni e i tour. Ulteriori punti a favore sono il massimo grip in curva e la lunga durata. È un all-rounder pronto per qualsiasi sfida, anche la più impegnativa.

LE MODÈLE POLYVALENT DU SEGMENT PERFORMANCE. Le Grand Sport Race pousse à la performance. C'est un pneu complet et équilibré avec une protection anticrevaion et suffisamment de PureGrip Compound sur la surface de roulement qui lui permettent d'avaler sans effort les nombreux kilomètres de courses et d'entraînement. Il offre une adhérence maximale en courbes et un roulement confortable: ce multi-talents est prêt à relever tous les défis, quels qu'ils soient.

Ultra Sport III

PNEUMATICI MODERNI PER CHI SI AVVICINA ALLE GARE IN BICICLETTA. Gomme adatte per il ciclismo in genere e per le competizioni. Un assortimento completo per allestire al meglio la tua bici con un eccellente rapporto qualità/prezzo. Disponibili in molte sezioni e colorazioni.

NOUVELLE GÉNÉRATION DE PNEU POUR QUI DÉCOUVRE LE VÉLO. Pneus pour toutes pratiques route et compétitions. Assortiment complet pour améliorer votre vélo avec un rapport qualité-prix exceptionnel. Disponible dans de nombreuses tailles et couleurs.



ARTICLE	EAN	ETRTO	DIMENSION	COLOR/SIDEWALL	TECHNOLOGY	WEIGHT	BAR	MAX.BAR	PRICE (€)
Grand Sport Race									
C0150001	4019238586565	23-622	700x23 C	black foldable	NyTech Breaker	230g	7,5	8,5	39,99
C0150027	4019238587319	25-622	700x25 C	black foldable	NyTech Breaker	270g	6,5	8,5	39,99
C0150118	4019238621105	28-622	700x28 C	black foldable	NyTech Breaker	330g	5,5	8,0	39,99
Ultra Sport III									
C0150449	4019238026641	23-622	700x23 C	black skin foldable	Performance	320g	7,5	8,5	29,99
C0150457	4019238026849	25-622	700x25 C	black skin foldable	Performance	270g	6,5	8,5	29,99
C0150466	4019238026917	28-622	700x28 C	black skin foldable	Performance	420g	5,5	8,0	29,99

TUBULAR





Competition

ALL-ROUNDER NELLA CORSA PROFESSIONISTICA. Competition è un all-rounder di utilizzo professionale all'altezza del livello World Tour. È un versatile tuttotfare, veloce ed agile, che emerge al termine delle maggiori competizioni al mondo grazie al carattere sempre combattivo. Spicca per la valida miscela sviluppata specificamente da Continental e per l'inserito di protezione dalle forature.

LE MODÈLE POLYVALENT DU MONDE DES PROS. Le Competition est un multi-talents qui répond à toute les exigences des ProTour et autres compétitions. Ce boyau s'adapte à toutes les conditions de route et apporte agilité et vitesse. Il fait preuve d'un caractère des plus combattifs. Le mélange de gomme performant développé par Continental combiné à une protection anti-crevaisson ultra efficace lui fait prendre le rôle d'un avant-gardiste.

Giro

COMPAGNO DI ALLENAMENTO PER PRINCIPIANTI. Il tubolare Giro spicca per la durata elevata e per l'eccellente rapporto prezzo/prestazione/durata. Ottime le sue proprietà di rotolamento e per la robustezza garantita anche dopo molti chilometri di allenamento. Questo pneumatico è il compagno perfetto nell'allenamento e nei tour di chi vuole avvicinarsi in modo serio al ciclismo.

LE PARTENAIRE D'ENTRAÎNEMENT POUR LES DÉBUTANTS. Le Giro fait sensation grâce à sa grande capacité de kilométrage et son excellent rapport qualité-prix. Il se distingue par ses excellentes propriétés de roulage et sa robustesse et il est toujours prêt même après de nombreux kilomètres d'entraînement. Ce boyau est le compagnon idéal pour les débutants, pour l'entraînement et en randonnées.



ARTICLE	EAN	ETRTO	DIMENSION	COLOR/SIDEWALL	TECHNOLOGY	WEIGHT	BAR	MAX.BAR	PRICE (€)
Competition									
C0196189	4019238549126	-	28"x25 mm	black	Vectran Breaker	280g	8,0	12,0	130,99
Giro									
C0196017	4019238107715	-	28"x22 mm	black/transparent	Performance	390g	8,0	10,0	39,99



Sprinter

A CACCIA DI VITTORIE. Lo Sprinter è caratterizzato da eccezionali proprietà di rotolamento grazie alla carcassa morbida. Offre il massimo nelle gare a circuito o nel triathlon. È la risposta giusta per chi chiede massima accelerazione e a questo aggiunge un peso ridotto e una manovrabilità equilibrata, grazie al suo profilo perfettamente slick.

LA CHASSE AUX POINTS. Le Sprinter se distingue par ses excellentes propriétés de roulement grâce à sa carcasse souple. Il joue ses atouts surtout dans le domaine des critériums. On peut se fier à ce boyau quand il est question d'accélération maximale. Ce boyau de compétition se distingue par son faible poids et sa conduite équilibrée.

Sprinter Gatorskin

UN CLASSICO PER LE GRANDI CLASSICHE. A suo agio sulle strade del Giro delle Fiandre, della Parigi-Roubaix o della Milano-Sanremo. È uno pneumatico che si caratterizza per durata, per resistenza anche su fondi dissestati e per l'elevata protezione dalle forature. Incamera grandi quantità d'aria, ad ulteriore garanzia di sicurezza, scorrevolezza e comfort, anche negli attraversamenti veloci sul pavé.

LE CHASSEUR CLASSIQUE PASSIONNÉ. Le Sprinter Gatorskin est chez lui sur les routes de Flandre, de Roubaix ou de San Remo. Ce boyau développé spécialement pour les courses classiques sait convaincre par sa grande résistance aux crevaisons et sa longévité kilométrique. Son volume important assure une sécurité supplémentaire et un roulement encore meilleur. Tout cela offre un grand confort sur la route même à pleine vitesse sur les pavés.



Safety System



Safety System



ARTICLE	EAN	ETRTO	DIMENSION	COLOR/SIDEWALL	TECHNOLOGY	WEIGHT	BAR	MAX.BAR	PRICE (€)
Sprinter									
C0196244	4019238674576	-	28"x25 mm	black	SafetySystem Breaker	295g	8,0	12,0	66,99
Sprinter Gatorskin									
C0196187	4019238549089	-	28"x25 mm	black	SafetySystem Breaker	300g	8,0	12,0	84,99



Vectran™ Breaker

Vectran™ viene prodotto dal polimero a cristalli liquidi Vectra. Si ottiene un filato termoplastico a fibre multiple. Questo tessuto in parte cristallino è più resistente al taglio rispetto all'aramide, è dotato di una resistenza alla trazione cinque volte superiore dell'acciaio ed è allo stesso tempo più leggero di un corrispondente filo di nylon. Vectran™ mantiene queste caratteristiche anche alle condizioni climatiche più ostili.

La référence en matière de protection anti-crevaisson. Vectran™ est un fil high-tech synthétique dont le modèle est pris dans la nature. Comme la soie d'araignée, Vectran™ est un polymère de cristaux liquide [LPC]. Vectran™ est tissé à partir du polymère à cristaux liquides Vectra et retravaillé en un réseau multifibres. La soie d'araignée et le composé Vectran™ possèdent une énorme résistance aux déchirures pour un poids très limité. Exactement les caractéristiques qui conviennent pour être utilisées en dispositif anti-crevaisson dans un pneu Continental. Vectran™ Breaker est plus léger, plus flexible et protège encore mieux des coupures qu'une protection anti-crevaisson en Nylon. La résistance au roulement n'est pas affectée par Vectran™ Breaker.

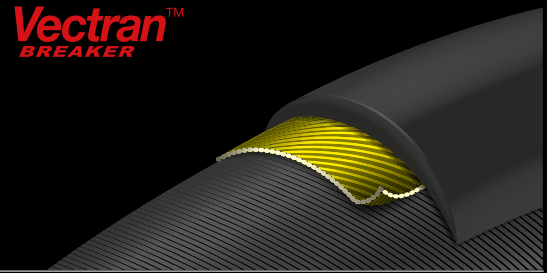

PolyX Breaker™

Resistente alla foratura. Con il PolyX Breaker® applichiamo il know-how acquisito in ambito automobilistico nel segmento motociclistico agli pneumatici per biciclette: sugli pneumatici per autovettura il poliestere viene utilizzato da anni, con grande successo ed esiti molto positivi. Estremamente resistente, la fibra di poliestere viene tessuta a maglie strette incrociate; in questo modo si raggiunge un'elevata densità del tessuto che rende il PolyX Breaker® non solo resistente alla perforazione da parte di corpi estranei ma anche particolarmente protettivo verso le forature.

Résistant aux perforations et aux coupures. Avec PolyX Breaker®, le savoir faire automobile est appliqué au domaine du vélo: le polyester est, depuis des années utilisé avec succès dans les pneus voitures et à fait ses preuves à de nombreuses reprises. Les fibres de polyester extrêmement résistantes sont étroitement et finement tissées en croix. De la sorte, on obtient un réseau très dense, qui rend le PolyX Breaker® non seulement résistant aux corps étrangers, mais également solide face aux perforations. Là aussi, la résistance au roulement n'est pas non plus affectée par PolyX Breaker®.

PolyX Breaker™

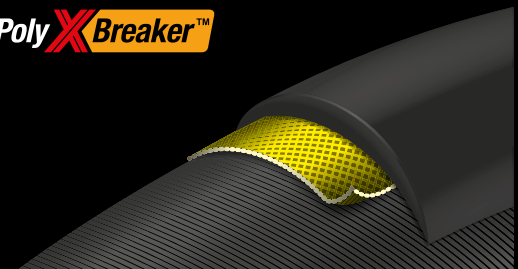

DuraSkin®

DuraSkin®. Gli pneumatici dotati di protezione delle pareti DuraSkin® devono poter affrontare qualsiasi situazione. Vengono utilizzati in condizioni estreme. Sulle biciclette dei messenger gli pneumatici strisciano sui bordi dei marciapiedi, sulle biciclette da viaggio attraversano continenti senza usurarsi, mentre nelle gare ciclistiche devono superare le prove più ardue, come ad esempio quelle della Parigi-Roubaix. Il tessuto di poliammide di alta qualità protegge efficacemente il fianco dello pneumatico e lo rende idoneo a qualsiasi situazione estrema. Questi pneumatici sono contraddistinti da tutti gli altri dal fianco di colore marrone.

Prêt pour rouler dans les pires conditions. Les pneus équipés de la protection DuraSkin® sur les flancs sont prêts pour avoir la vie dure. Ils peuvent être utilisés dans les conditions les plus extrêmes. Les pneus des vélos de coursiers frottent sur les bords de trottoirs, durant les randonnées ils sillonnent les continents sans s'user, pendant des courses ils doivent être d'une solidité à toute épreuve, comme lors du Paris-Roubaix. Le tissage en polyamide de très haute qualité protège efficacement les flancs du pneu et prémunissent le pneu contre tous les aléas. Ces pneus se distinguent du tout-venant par leurs flancs marron.

DuraSkin®

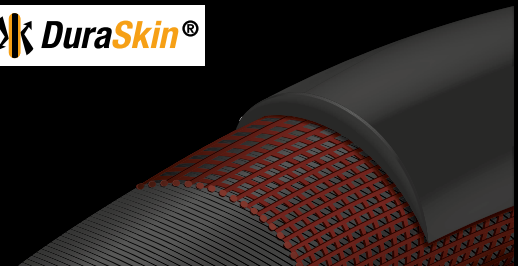

NyTech Breaker

Una tecnologia antiforatura strutturata con fibre di nylon protettive. È simile al Kevlar ma con una bassa resistenza al rotolamento e con un peso ridotto.

Une technologie de protection anti crevaissons faite de fibres de nylon - protégeant comme le Kevlar, mais avec une faible résistance au roulement, sans en augmenter le poids.

NyTech BREAKER

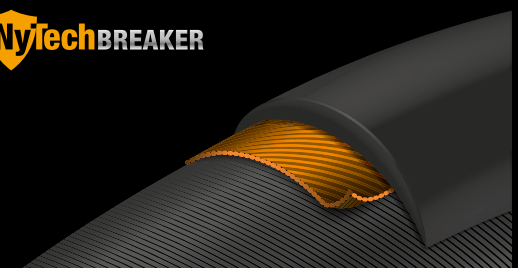

Safety System

Resistente alle forature e ai tagli, ma allo stesso tempo leggero e flessibile, lo pneumatico si adatta meglio al fondo stradale. Assicura caratteristiche di guida molto votate al comfort.

Résistant aux perforations et aux coupures tout en restant léger et souple, le pneu s'adapte mieux au terrain pour une tenue de route des plus agréables.

Safety  System

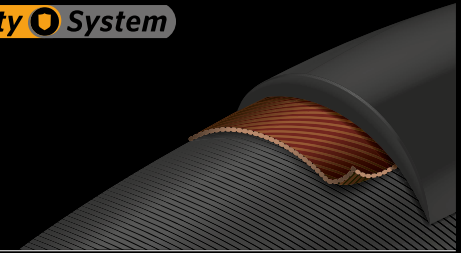

BlackChili Compound

La miscela per copertura unica nel suo genere, prodotta solo in Germania, che rivoluzionerà gli pneumatici per biciclette! Con la BlackChili Compound il compromesso tra maggior grip e bassa resistenza al rotolamento è stato portato ai massimi livelli in assoluto. I tanti primati ottenuti nei test certificano vantaggi misurabili e registrabili sia in laboratorio che sulla strada. I polimeri di nuova generazione, il particolato carbonioso frutto di nanotecnologie e gli agenti di carica garantiscono una performance davvero unica. Rappresenta il non plus ultra nei relativi ambiti di utilizzo: dalle coperture delle MTB da downhill agli pneumatici per bici da cronometro. BlackChili Compound migliora la resistenza al rotolamento del 26 per cento e offre allo stesso tempo un grip superiore di circa il 30 per cento rispetto alle mescole di silice attivato. Inoltre, gli pneumatici realizzati con il BlackChili Compound offrono una resa chilometrica superiore e, diversamente da mescole multiple, una performance costante dal primo all'ultimo chilometro.

A korbach, en Allemagne, où se trouve le siège de notre département recherche et développement pour les pneus de vélos Continental, cela fait longtemps que nos ingénieurs se creusent la tête sur un problème fondamental concernant la structure d'un pneu. En effet, les qualités de roulement du mélange de caoutchouc d'un pneu sont définies, de façon déterminante, par l'interaction de trois facteurs: le frottement statique [adhérence], la résistance au roulement et la longévité. Le dilemme est le suivant: si on améliore l'un de ces facteurs, au moins un autre de ces facteurs va par contre se dégrader. Un pneu ayant une adhérence maximale s'use plus rapidement et roule moins vite. Inversement, si on confectionne un pneu qui est plus rapide ou qui dure plus longtemps, alors son adhérence diminue. Avec la technologie de pointe d'aujourd'hui, à savoir la gomme à silice activée, on avait déjà atteint un bon compromis. Mais nos concepteurs voulaient obtenir plus. En suivant des chemins tout nouveaux, ils ont réussi en 2008 à mettre au point un mélange de gomme révolutionnaire: c'était le premier pas vers ce que l'on connaît sous le nom de Black Chili. Ce mélange de gomme totalement nouveau est basé sur les connaissances les plus récentes fournies par la recherche sur les polymères et les matières premières.



PureGrip Compound

La miscela PureGrip è derivata da una miscela di Silice attivata ed è un buon esempio di come noi integriamo continuamente i feedback dei clienti verso il settore della ricerca e sviluppo. Questa miscela tecnologica è perfettamente declinata della miscela BlackChili Compound. Il nome PureGrip fa esattamente ciò che dice: un grip e una durezza incredibilmente superiori sono le caratteristiche distintive di questo compound. Utilizziamo la PureGrip sui nostri articoli della linea Performance e sulla gamma mountain bike.

Fabriquée à partir d'un composé de silice activée, le mélange de gomme PureGrip est la parfaite illustration de la façon dont nous prenons en compte les retours de nos clients dans nos efforts de recherche et développement. Cette technologie est une alternative au mélange de gomme BlackChili. Son nom, "PureGrip", est on ne peut plus explicite: ce composant garantit une parfaite adhérence et une durabilité exceptionnelle. Nous utilisons PureGrip dans les produits de notre gamme Performance pour les vélos de route et VTT.



Tire Positioning System

La competenzaa dallo sport motociclistico, adattata specificamente alla bicicletta da competizione per assecondare i requisiti specifici della ruota anteriore e della posteriore. L'anteriore: agile e reattiva. Lo pneumatico più stretto assicura una riduzione della resistenza all'aria e migliora le caratteristiche di sterzata. La posteriore: confortevole e ammortizzante. Con la sua superficie di contatto al suolo leggermente più ampia lo pneumatico assicura una migliore trazione. La scorrevolezza viene migliorata grazie alla composizione ottimizzata della miscela, finalizzata alla resistenza al rotolamento. Il risultato è un sistema ruota anteriore e posteriore all'avanguardia, dove gli pneumatici sono stati attentamente accoppiati l'uno con l'altro.

Avec TirePositioning® System, on atteint les dernières limites de ce qui est techniquement possible aujourd'hui. Les motards le savent depuis longtemps: les qualités attendues du pneu avant son différentes de celles demandées au pneu arrière. Le pneu avant plus étroit diminue la résistance au vent et procure une plus grande maniabilité dans les virages. Un mélange pour bande de roulement à adhérence optimisée procure une meilleure adhérence, en particulier dans les virages sur route mouillée. Le pneu arrière plus large possède, grâce à une surface de contact plus grande, une meilleure traction et offre en même temps plus de confort. Grâce à un mélange qui diminue la résistance au roulement et à une surface de contact plus grande à l'arrière, l'abrasion se voit diminuée. Le résultat est notre système novateur pneu avant/pneu arrière pour la compétition: que l'on retrouve sur le kit GP Attack/Force. Nouveau: la technologie TPS également proposée en boyaux avec le Set Attack/Force Comp.



GRAVEL





Terra Speed

SCEGLI UNA STRADA DIVERSA, SCEGLI TERRA. Per la tua traccia fuori strada. Per più comfort. Per l'avventura. Che sia un giro lungo, o la scorciatoia per la strada di casa. La nuova serie gravel Terra di Continental ti porta proprio dove vuoi arrivare. Terra Speed è il modello più veloce della nostra gamma. Fatto per accompagnarti tra l'asfalto e la sabbia. Fatto per accompagnarti tra percorsi sconnessi o veloci. Scegli una strada diversa, scegli Terra.

CHOISISSEZ UNE AUTRE ROUTE, CHOISISSEZ TERRA. Pour vos parcours en dehors de la route. Pour plus de confort. Pour l'aventure. Que ce soit un long trajet, ou le raccourci vers la maison. Le nouveau pneu Gravel Terra de Continental vous emmène là où vous souhaitez aller. Terra Speed est le modèle le plus rapide de notre gamme. Fait pour vous accompagner entre l'asphalte et le sable. Fait pour vous accompagner sur les itinéraires accidentés ou rapides. Choisissez un autre chemin, choisissez Terra.

Terra Trail

SCEGLI UNA STRADA DIVERSA, SCEGLI TERRA. Per la tua traccia fuori strada. Per più comfort. Per l'avventura. Che sia un giro lungo, o la scorciatoia per la strada di casa. La nuova serie gravel Terra di Continental ti porta proprio dove vuoi arrivare. Il modello Terra Trail è il più nobile della nostra gamma. Fatto per accompagnarti tra percorsi sconnessi o veloci. Scegli una strada diversa, scegli Terra.

CHOISISSEZ UNE AUTRE ROUTE, CHOISISSEZ TERRA. Pour vos parcours en dehors de la route. Pour plus de confort. Pour l'aventure. Que ce soit un long trajet, ou le raccourci vers la maison. Le nouveau pneu Gravel Terra de Continental vous emmène là où vous souhaitez aller. Le modèle Terra Trail est le plus noble de notre gamme. Fait pour vous accompagner sur les itinéraires accidentés ou rapides. Choisissez un autre chemin, choisissez Terra.



ARTICLE	EAN	ETRTO	DIMENSION	COLOR/SIDEWALL	TECHNOLOGY	WEIGHT	BAR	MAX.BAR	PRICE (€)
Terra Speed									
C0101720	4019238029772	35-584	650x35 B 27.5x1.35	black/cream skin fold.	ProTecton	350g	3,0	5,0	69,99
C0101718	4019238029611	40-584	650x40 B 27.5x1.50	black/cream skin fold.	ProTecton	420g	3,0	5,0	69,99
C0101700	4019238026955	35-622	700x35 C 28x1.35	black/cream skin fold.	ProTecton	360g	3,0	5,0	69,99
C0101702	4019238027020	40-622	700x40 C 28x1.50	black/cream skin fold.	ProTecton	440g	3,0	5,0	69,99
C0101837	4019238052053	40-622	700x40 C 28x1.50	black/transp. skin fold.	ProTecton	440g	3,0	5,0	69,99
C0102007	4019238083439	45-622	700x45 C 28x1.70	black/transp. skin fold.	ProTecton	490g	3,0	5,0	69,99
C0101719	4019238029796	35-584	650x35 B 27.5x1.35	black/black foldable	ProTecton	390g	3,0	5,0	69,99
C0101693	4019238027013	35-622	700x35 C 28x1.35	black/black foldable	ProTecton	410g	3,0	5,0	69,99
C0101717	4019238029635	40-584	650x40 B 27.5x1.50	black/black foldable	ProTecton	420g	3,0	5,0	69,99
C0101694	4019238027099	40-622	700x40 C 28x1.50	black/black foldable	ProTecton	440g	3,0	5,0	69,99
Terra Trail									
C0101716	4019238029659	40-584	650x40 B 27.5x1.50	black/cream skin fold.	ProTecton	440g	3,0	5,0	69,99
C0101701	4019238027044	40-622	700x40 C 28x1.50	black/cream skin fold.	ProTecton	440g	3,0	5,0	69,99
C0101836	4019238052060	40-622	700x40 C 28x1.50	black/transp. skin fold.	ProTecton	440g	3,0	5,0	69,99
C0101715	4019238029673	40-584	650x40 B 27.5x1.50	black/black skin fold.	ProTecton	440g	3,0	5,0	69,99
C0101697	4019238027075	40-622	700x40 C 28x1.50	black/black skin fold.	ProTecton	460g	3,0	5,0	69,99
C0150509	4019238038507	47-584	650x47 B 27.5x1.75	black/black skin fold.	ShieldWall Syst.	520g	2,5	4,5	39,99
C0150508	4019238038538	47-584	650x47 B 27.5x1.75	black/cream skin fold.	ShieldWall Syst.	510g	2,5	4,5	39,99
C0150503	4019238038460	35-622	700x35 C 28x1.35	black/black skin fold.	ShieldWall Syst.	425g	3,0	5,0	39,99
C0150505	4019238038491	35-622	700x35 C 28x1.35	black/cream skin fold.	ShieldWall Syst.	445g	3,0	5,0	39,99
C0150507	4019238038545	40-622	700x40 C 28x1.50	black/black skin fold.	ShieldWall Syst.	495g	3,0	5,0	39,99
C0150673	4019238064506	40-622	700x40 C 28x1.50	black/brown skin fold.	ShieldWall Syst.	440g	3,0	5,0	39,99
C0150675	4019238064476	45-622	700x45 C 28x1.70	black/black skin fold.	ShieldWall Syst.	500g	2,5	4,5	39,99

MOUNTAIN BIKE





Umido
Terrain Mixte



Kryptotal Fr

LA SCELTA PER TERRENI E CONDIZIONI MISTI. Progettato per abbinarsi perfettamente al Kryptotal Re e ottimizzato per manovrabilità e agilità della ruota anteriore. Ideale per terreni misti e per l'impiego Trail, Enduro o DH Gravity.

CONÇU POUR LES TERRAINS ET CONDITIONS MIXTES. Conçu pour fonctionner avec le Kryptotal Re et optimiser la maniableté et l'agilité de la roue avant. Idéal sur les terrains mixtes en trail, enduro et descente.

Kryptotal Re

LA SCELTA PER TERRENI E CONDIZIONI MISTI. Ottimizzato per la ruota posteriore, questo pneumatico offre massima versatilità ed equilibrio tra aderenza, trazione in frenata e resistenza al rotolamento. Nato per eccellere sui terreni misti, è la scelta ideale per raidare al limite nella tua disciplina preferita: Trail, Enduro o DH Gravity.

CONÇU POUR LES TERRAINS ET CONDITIONS MIXTES. Conçu pour la roue arrière, ce pneu polyvalent est le parfait équilibre entre stabilité, motricité et résistance au roulement. Idéal pour repousser vos limites en trail, enduro ou en descente.



ARTICLE	EAN	ETRTO	DIMENSION	COLOR/SIDEWALL	TECHNOLOGY	WEIGHT	BAR	MAX.BARPRICE (€)
Kryptotal-F 2.4								
C0101957	4019238070491	60-622	29" 29x2.40	black/black fold. skin	Downhill/Super Soft Comp.	1290g	2,5 3,5	99,00
C0150694	4019238074116	60-584	27.5" 27.5x2.40	black/black fold. skin	Enduro/Soft Comp.	1080g	2,5 3,5	85,00
C0150696	4019238074079	60-622	29" 29x2.40	black/black fold. skin	Enduro/Soft Comp.	1125g	2,5 3,5	85,00
C0150695	4019238074093	60-584	27.5" 27.5x2.40	black/black fold. skin	Trail/Endurance Comp.	1000g	2,5 3,5	73,00
C0150697	4019238074055	60-622	29" 29x2.40	black/black fold. skin	Trail/Endurance Comp.	1040g	2,5 3,5	73,00
Kryptotal-R 2.4								
C0101991	4019238080780	60-584	27.5" 27.5x2.40	black/black fold. skin	Downhill/Soft Comp.	1220g	2,5 3,5	95,00
C0101992	4019238080773	60-622	29" 29x2.40	black/black fold. skin	Downhill/Soft Comp.	1290g	2,5 3,5	95,00
C0101993	4019238080766	60-584	27.5" 27.5x2.40	black/black fold. skin	Enduro/Soft Comp.	1080g	2,5 3,5	85,00
C0150634	4019238063127	60-622	29" 29x2.40	black/black fold. skin	Enduro/Soft Comp.	1125g	2,5 3,5	85,00
C0150637	4019238063059	60-584	27.5" 27.5x2.40	black/black fold. skin	Trail/Endurance Comp.	1000g	2,5 3,5	73,00
C0150638	4019238063042	60-622	29" 29x2.40	black/black fold. skin	Trail/Endurance Comp.	1040g	2,5 3,5	73,00
Kryptotal-R 2.6								
C0150635	4019238063097	65-584	27.5" 27.5x2.60	black/black fold. skin	Enduro/Soft Comp.	1220g	2,0 3,0	89,00
C0150636	4019238063080	65-622	29" 29x2.60	black/black fold. skin	Enduro/Soft Comp.	1275g	2,0 3,0	89,00
C0150639	4019238063011	65-584	27.5" 27.5x2.60	black/black fold. skin	Trail/Endurance Comp.	1100g	2,0 3,0	81,00
C0150640	4019238063004	65-622	29" 29x2.60	black/black fold. skin	Trail/Endurance Comp.	1200g	2,0 3,0	81,00



Bagnato
Terrain Meuble



Argotal

LA SCELTA PER TERRENI MORBIDI. Ideale per terreni smossi, questo pneumatico offre massima stabilità in curva e maggiore aderenza laterale. Il disegno aperto del battistrada aumenta la capacità autopulente, l'ideale per spingere al massimo tra sterrati e polvere.

CONÇU POUR LES TERRAINS MEUBLES. Pneu idéal pour les terrains meubles, avec une adhérence latérale accrue pour une bonne stabilité dans les virages. La bande de roulement ouverte permet un auto-nettoyage afin que vous puissiez repousser vos limites de conduite sur terrains la poussiéreux et meubles.

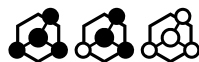

ARTICLE	EAN	ETRT0	DIMENSION	COLOR/SIDEWALL	TECHNOLOGY	WEIGHT	BAR	MAX.BAR	PRICE (€)
Argotal 2.4									
C0150684	4019238068016	60-584	27.5" 27.5x2.40	black/black fold. skin	Enduro/Soft Comp.	1080g	2,5	3,5	85,00
C0150686	4019238068078	60-622	29" 29x2.40	black/black fold. skin	Enduro/Soft Comp.	1160g	2,5	3,5	85,00
C0150689	4019238067972	60-584	27.5" 27.5x2.40	black/black fold. skin	Trail/Endurance Comp.	1000g	2,5	3,5	73,00
C0150691	4019238068030	60-622	29" 29x2.40	black/black fold. skin	Trail/Endurance Comp.	1040g	2,5	3,5	73,00
Argotal 2.6									
C0150685	4019238067910	65-584	27.5" 27.5x2.60	black/black fold. skin	Enduro/Soft Comp.	1220g	2,0	3,0	89,00
C0150688	4019238067958	65-622	29" 29x2.60	black/black fold. skin	Enduro/Soft Comp.	1275g	2,0	3,0	89,00
C0150690	4019238067897	65-584	27.5" 27.5x2.60	black/black fold. skin	Trail/Endurance Comp.	1100g	2,0	3,0	81,00
C0150692	4019238067934	65-622	29" 29x2.60	black/black fold. skin	Trail/Endurance Comp.	1200g	2,0	3,0	81,00



Asciutto
Terrain Dur



Xynotal

LA SCELTA PER TERRENI COMPATTI E CONDIZIONI DI ASCIUTTO. Perfetto per superfici dure e rocciose. Bassa resistenza al rotolamento e bordi di contatto studiati per migliorare la trazione e la frenata. Ideale per le uscite gravity veloci, quando serve maggiore grip e maggiore sicurezza.

CONÇU POUR LES TERRAINS DURS ET LES CONDITIONS SÈCHES. Parfait pour les surfaces dures et rocailleuses. Profiter d'un roulage rapide et d'un freinage puissant en toute confiance grâce à une adhérence continue lorsque vous en avez le plus besoin.

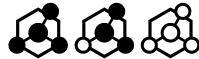

ARTICLE	EAN	ETRTO	DIMENSION	COLOR/SIDEWALL	TECHNOLOGY	WEIGHT	BAR	MAX.BAR	PRICE (€)
Xynotal 2.4									
C0150646	4019238063257	60-584	27.5" 27.5x2.40	black/black fold. skin	Trail/Endurance Comp.	1000g	2,5	3,5	73,00
C0150647	4019238063240	60-622	29" 29x2.40	black/black fold. skin	Trail/Endurance Comp.	1040g	2,5	3,5	73,00

4 NAMES, 5 PATTERNS, 1

The all new G

CAS

TERRAIN

HARD PACK

MIXED

LOOSE

MUD

TRAIL

27.5" X 2.4 29" X 2.4

XY **XY**

XYNOTAL XYNOTAL

27.5" X 2.4 Fr 29" X 2.4 Fr

KR **KR**

KRYPTOTAL KRYPTOTAL

27.5" X 2.4 Re 27.5" X 2.6 Re

KR **KR**

KRYPTOTAL KRYPTOTAL

29" X 2.4 Re 29" X 2.6 Re

KR **KR**

KRYPTOTAL KRYPTOTAL

27.5" X 2.4 27.5" X 2.6

AR **AR**

ARGOTAL ARGOTAL

29" X 2.4 29" X 2.6

AR **AR**

ARGOTAL ARGOTAL

ENDURO

27.5" X 2.4

XY

XYNOTAL

29" X 2.4

XY

XYNOTAL

27.5" X 2.4 Fr

KR

KRYPTOTAL

29" X 2.4 Fr

KR

KRYPTOTAL

27.5" X 2.4 Re

KR

KRYPTOTAL

27.5" X 2.6 Re

KR

KRYPTOTAL

27.5" X 2.4

AR

ARGOTAL

27.5" X 2.6

AR

ARGOTAL

TERRAIN



HARDPACK



MIXED



LOOSE



MUD

COMPOUND



SUPER SOFT



SOFT



ENDURANCE

INFINITE POSSIBILITIES

Gravity Range

ING

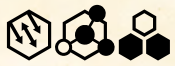

**DOWNHILL
SOFT**

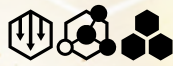

**DOWNHILL
SUPER SOFT**

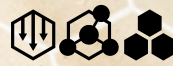

27.5" X 2.4

29" X 2.4

27.5" X 2.4

29" X 2.4

XY
XYNOTAL

XY
XYNOTAL

XY
XYNOTAL

XY
XYNOTAL

27.5" X 2.4

Fr

29" X 2.4

Fr

KR
KRYPTOTAL

KR
KRYPTOTAL

29" X 2.4

Re

29" X 2.6

Re

KR
KRYPTOTAL

KR
KRYPTOTAL

27.5" X 2.4

Re

29" X 2.4

Re

KR
KRYPTOTAL

KR
KRYPTOTAL

27.5" X 2.4

Re

29" X 2.4

Re

KR
KRYPTOTAL

KR
KRYPTOTAL

29" X 2.4

29" X 2.6

27.5" X 2.4

29" X 2.4

27.5" X 2.4

29" X 2.4

AR
ARGOTAL

AR
ARGOTAL

AR
ARGOTAL

AR
ARGOTAL

AR
ARGOTAL

AR
ARGOTAL

27.5" X 2.4

29" X 2.4

HY
HYDROTAL

HY
HYDROTAL

RIDING



DOWNHILL



ENDURO



TRAIL

CASING



DOWNHILL



ENDURO



TRAIL



Cross King

UN ALL-ROUNDER PRIMO DELLA CLASSE, COLLAUDATO ANCHE NELLE COMPETIZIONI.

- pneumatico versatile per la gara e il trail, stabile in curva e comodo
- buona aderenza, declinato con varie tecnologie
- pneumatico scorrevole, il suo battistrada si adatta a qualsiasi terreno

UN MODÈLE POLYVALENT DE PREMIÈRE CLASSE QUI A ÉGALEMENT FAIT SES PREUVES EN COMPÉTITION.

- pneu versatile, aussi à l'aise en compétition que sur piste, très adhérent dans les virages et confortable
- bonne adhérence, avec plusieurs technologies disponibles
- roulement souple qui s'adapte à tous types de terrain grâce à une bande de roulement spéciale



ARTICLE	EAN	ETRTO	DIMENSION	COLOR/SIDEWALL	TECHNOLOGY	WEIGHT	BAR	MAX.BAR	PRICE (€)
Cross-King 2.2 ProTecton									
C0101483	4019238798036	55-559	26x2.2	black skin foldable	ProTecton	590g	3,0	4,0	67,90
C0101465	4019238798050	55-584	27.5x2.2	black skin foldable	ProTecton	620g	3,0	4,0	67,90
C0101965	4019238071474	55-584	27.5x2.2	black/transp. fold.	ProTecton	630g	3,0	4,0	67,90
C0101471	4019238798043	55-622	29x2.2	black skin foldable	ProTecton	660g	3,0	4,0	67,90
C0101966	4019238071467	55-622	29x2.2	black/transp. fold.	ProTecton	670g	3,0	4,0	67,90
Cross King 2.2 ShieldWall									
C0150303	4019238797480	55-559	26x2.2	black skin foldable	ShieldWall System	700g	3,0	4,0	36,90
C0150291	4019238797503	55-584	27.5x2.2	black skin foldable	ShieldWall System	740g	3,0	4,0	36,90
C0150295	4019238797497	55-622	29x2.2	black skin foldable	ShieldWall System	790g	3,0	4,0	36,90
Cross King 2.3 ProTecton									
C0101463	4019238798364	58-584	27.5x2.3	black foldable	ProTecton	730g	2,8	3,8	67,90
C0101475	4019238798418	58-622	29x2.3	black foldable	ProTecton	770g	2,8	3,8	67,90
Cross King 2.3 ShieldWall									
C0150302	4019238798319	58-559	26x2.3	black foldable	ShieldWall System	730g	2,8	3,8	36,90
C0150290	4019238798296	58-584	27.5x2.3	black foldable	ShieldWall System	780g	2,8	3,8	36,90
C0150297	4019238798326	58-622	29x2.3	black foldable	ShieldWall System	830g	2,8	3,8	36,90
Cross King 2.6 ShieldWall									
C0150337	4019238003581	65-584	27.5x2.60	black skin foldable	ShieldWall System	920g	2,0	3,0	40,99
C0150502	4019238037258	65-622	29x2.60	black skin foldable	ShieldWall System	995g	2,0	3,0	40,99
Cross-King 2.6 ProTecton									
C0101384	4019238773606	65-584	27.5x2.6	black foldable	ProTecton	810g	2,0	3,0	89,99
Cross-King 2.8 ShieldWall									
C0150336	4019238003611	70-584	27.5x2.80	black skin foldable	ShieldWall System	1040	1,8	2,8	40,99



Mountain King

SICURO A SPASSO TRA LA NATURA. Il Mountain King dà il meglio di sé sulle biciclette da all mountain. La scolpita direzionale e antisdrucchiante lo rendono un ideale pneumatico anteriore, visto che i tasselli centrali mordono, mentre quelli laterali aderiscono ed offrono un buon grip su qualsiasi terreno. È il compagno perfetto per le uscite sportive.

TRAVERSER LES TERRAINS EN TOUTE SÉCURITÉ. Le Mountain King révèle ses qualités en All Mountain. Grâce à la géométrie ouverte et à bonne adhérence de son profil, c'est le pneu avant idéal. Le mordant de ses crampons médians et l'adhérence de ses crampons latéraux lui donne un très bon grip sur tous les terrains. Ce pneu est le compagnon idéal pour les virées sportives.



ARTICLE	EAN	ETRT0	DIMENSION	COLOR/SIDEWALL	TECHNOLOGY	WEIGHT	BAR	MAX.BAR	PRICE (€)
Mountain King 2.3 ProTecton									
C0101461	4019238798371	58-584	27.5x2.3	black skin foldable	ProTecton	730g	2,8	3,8	69,90
C0101469	4019238798432	58-622	29x2.3	black skin foldable	ProTecton	770g	2,8	3,8	69,90
Mountain King III 2.3 ShieldWall									
C0150301	4019238798333	58-559	26x2.3	black skin foldable	ShieldWall System	730g	2,8	3,8	36,99
C0150289	4019238798302	58-584	27.5x2.3	black skin foldable	ShieldWall System	770g	2,8	3,8	36,99
C0150294	4019238798340	58-622	29x2.3	black skin foldable	ShieldWall System	820g	2,8	3,8	36,99
Mountain King 2.6/2.8 ShieldWall									
C0150335	4019238003598	65-584	27.5x2.6	black skin foldable	ShieldWall System	935g	2,0	3,0	40,99
C0150334	4019238003628	70-584	27.5x2.8	black skin foldable	ShieldWall System	1020g	1,8	2,8	40,99
Mountain King 2.6 ProTecton									
C0101583	4019238003543	65-584	27.5x2.6	black foldable	ProTecton	810g	2,0	3,0	79,90



Race King

UN CLASSICO PER GLI AGONISTI. Il Race King è un classico tipo da competizione. È gettonatissimo nelle gare di cross-country o nelle marathon e si addice sia alle front che alle full suspended. Spicca per la bassa resistenza al rotolamento, ha una carcassa voluminosa e un'ottima capacità di smorzare i colpi. Il battistrada garantisce i requisiti più utili per il biker assiduo.

LE PREMIER CHOIX DES COUREURS. Le Race King est le type même du classique de compétition. Ce pneu est utilisé dans les courses de cross country ou les marathons et est également adapté aux hardtails et aux races fulls. Il sait convaincre par sa faible résistance au roulement, sa carcasse volumineuse et son excellent amortis. Son profil offre les meilleures conditions aux cyclistes assidus.



ARTICLE	EAN	ETRTO	DIMENSION	COLOR/SIDEWALL	TECHNOLOGY	WEIGHT	BAR	MAX.BAR	PRICE (€)
Race King 2.0 ShieldWall									
C0150309	4019238797527	50-584	27.5x2.0	black foldable	ShieldWall System	630g	3,5	4,5	36,90
C0150307	4019238797534	50-622	29x2.0	black foldable	ShieldWall System	660g	3,5	4,5	36,90
Race King 2.2 ProTaction									
C0101486	4019238798111	55-559	26x2.2	black skin foldable	ProTaction	560g	3,0	4,0	67,90
C0101467	4019238798135	55-584	27.5x2.2	black skin foldable	ProTaction	590g	3,0	4,0	67,90
C0101962	4019238071504	55-584	27.5x2.2	black/transp. fold.	ProTaction	590g	3,0	4,0	67,90
C0101473	4019238798128	55-622	29x2.2	black skin foldable	ProTaction	620g	3,0	4,0	67,90
C0101963	4019238071498	55-622	29x2.2	black/transp. fold.	ProTaction	630g	3,0	4,0	67,90
Race King 2.2 ShieldWall									
C0150304	4019238797541	55-559	26x2.2	black skin foldable	ShieldWall System	660g	3,0	4,0	36,99
C0150292	4019238797565	55-584	27.5x2.2	black skin foldable	ShieldWall System	700g	3,0	4,0	36,99
C0150296	4019238797558	55-622	29x2.2	black skin foldable	ShieldWall System	740g	3,0	4,0	36,99



Tubeless Ready

Il nostro pneumatico Tubeless Ready [TR] può essere usato con camera d'aria o liquido sigillante. Pneumatico e cerchio sono disegnati in modo che quando sono usati assieme si sigillano facilmente. Per motivi di sicurezza usiamo solo ruote progettate per essere Tubeless Ready. Gli pneumatici TR hanno un ulteriore design alleggerito. I loro fianchi sono meno permeabili all'aria e sono sigillati con uno speciale sigillante, per esempio il Conti RevoSealant.

Les pneus Tubeless Ready peuvent être utilisés au choix avec ou sans chambre à air. Pour être utilisé sans chambre à air, le pneu doit être étanchéifié avec un liquide préventif. Le talon révolutionnaire Tubeless Ready permet un montage simple du pneu sur la jante. Tous les pneus VTT Continental des gammes ProTecton et Performance sont Tubeless Ready. Pour un résultat d'étanchéité parfaite, nous recommandons l'utilisation du préventif Continental RevoSealant.



Adatto alle E-Bikes / Adapté aux E-Bikes

Per il nostro pneumatico per e-Bike ereditiamo gli oltre cento anni di esperienza con gli pneumatici per ciclomotori e moto. Tutti i nostri pneumatici da città/trekking hanno una velocità standard di almeno 25 km/h. Gli pneumatici siglati "e50" sono certificati anche per S-Pedelecs. La loro struttura di alta qualità assicura elevata protezione contro le forature, bassa resistenza al rotolamento e aggiunge un'alta durezza, grazie alla porzione motrice con struttura maggiorata.

Pour mettre au point notre pneu E-Bike nous avons tiré profit de notre expérience de plus de 100 ans dans le domaine du pneu cyclomoteur et moto. Tous nos pneus pour vélos de ville et trekking ont été conçus en fonction d'une vitesse minimum de 25 km/h. Ces pneus portant l'indication e50 sont également certifiés pour S-Pedelecs. Avec leur structure de haute qualité, la protection contre les crevaisons est élevée et la résistance au roulement faible préservant ainsi le pneu d'une usure prématurée créée par la force d'entraînement supplémentaire.



Continental



ProTecton

PER LA STRADA PIÙ DIFFICILE. Le nuove carcasse Continental ProTecton sono state ulteriormente migliorate: la fettuccia anti-foratura è stata applicata in modo uniforme su tutto l'arco di circonferenza dello pneumatico, così da renderlo particolarmente resistente alle lesioni e alle perforazioni di corpi estranei. Rispetto ai già apprezzati predecessori in DuraSkin® le carcasse ProTecton pesano il 25 per cento in meno e offrono il 30 per cento di protezione in più dalle forature. Migliorate sono anche la resistenza al rotolamento e le capacità di assorbire i colpi, che completano le qualità assolute della tecnologia "made in Germany" di questi prodotti. Versatili e universali, le carcasse ProTecton convincono anche grazie alla mescola BlackChili Compound e al design accattivante dei fianchi. Il nuovo tallone Revolution permette di utilizzarle come coperture tubeless ready; in questo caso per ottenere la migliore efficienza è consigliato l'utilizzo del nuovo sigillante Continental RevoSealant.

LA MANIÈRE FORTE. Les nouvelles carcasses Continental ProTecton n'ont jamais eu aussi belle allure. La bande de protection supplémentaire contre la crevaison la rend particulièrement résistante et insensible aux lésions ou à la pénétration de corps étrangers. Bande de roulement et flancs sont protégés de la même manière. Elles sont pourtant plus légères de 25% et assurent une protection anti-crevaison supérieure de 30% par rapport à leurs prédécesseurs armés de DuraSkin®. Par ailleurs, elles améliorent une fois de plus la résistance au roulement et l'amortissement. La nouvelle technologie "made in Germany" leur permet même de résister aux "trails" les plus durs du monde. Et elles ont encore un atout en poche: d'usage universel, elles séduisent de surcroît par le BlackChili Compound et le design attrayant des flancs. Le nouveau talon Revolution Tubeless Ready facilite l'utilisation en pneu Tubeless Ready. Pour des résultats idéaux de colmatage et de mise en oeuvre, nous recommandons d'utiliser le nouveau produit d'étanchéité Continental RevoSealant.



ShieldWall System

SISTEMA TUBELESS-READY E PROTEZIONE CONTRO LE FORATURE PER BIKER CON UN BUDGET LIMITATO. Il sistema ShieldWall unisce in modo ottimale alta protezione contro le forature, bassa resistenza al rotolamento e peso contenuto. Questo grazie a un ulteriore strato di protezione totale contro le forature, costituito da un tessuto con trama finemente intrecciata. Questo conferisce allo pneumatico elevata resistenza contro forature e lacerazioni. Nonostante il tessuto aggiuntivo, lo pneumatico ha ottime proprietà di smorzamento dei colpi e un alto grado di flessibilità per adattarsi perfettamente al terreno. Il rivoluzionario tallone tubeless ready permette un'installazione facile e semplice dello pneumatico. Per ottenere i migliori risultati nella sigillatura e nell'utilizzo si consiglia l'uso del sigillante Continental RevoSealant.

TUBELESS READY OFFRE LA PROTECTION CONTRE LA CREVAISON POUR LES CYCLISTES ATTENTIFS À LEUR BUDGET. Le ShieldWall system se caractérise par la combinaison optimale d'une haute protection contre les crevaisons et d'une faible résistance au roulement, avec un faible poids. Ceci est rendu possible grâce à une couche supplémentaire de protection en tissu finement tressé. Cela donne au pneu une grande résistance aux crevaisons et aux coupures. Malgré sa couche supplémentaire, le pneu a une très bonne capacité d'amortissement et un degré élevé de souplesse pour s'adapter à tout type de terrain. Le révolutionnaire tubeless ready permet un montage du pneu simple et facile. Pour obtenir de meilleurs résultats en matière d'étanchéité et d'utilisation, nous recommandons l'utilisation du nouveau produit d'étanchéité Continental RevoSealant sealant.



Performance

QUALITÀ DI FIDUCIA. PureGrip è la tecnologia di mescola utilizzata esclusivamente sulle coperture destinate alle alte prestazioni. Il nome parla da solo e unisce un'aderenza superiore e grande durezza. Non lasciare mai nessun ciclista nei guai è stato uno dei principali obiettivi a cui si è puntato nel momento in cui questa nuova mescola è stata sviluppata e poi prodotta, presso il nuovo stabilimento Continental in Cina. La Performance è applicata su una robusta carcassa in nylon da 60 TPI (fili per pollice) in modo da consegnare una copertura affidabile, resistente e adatta a chiudere a tenuta lo pneumatico di tipo tubeless, senza camera d'aria, assieme al liquido sigillante Conti RevoSealant. Da parte loro, i talloni pieghevoli in morbida ma robusta aramide assicurano una tenuta salda sul cerchio. Gli pneumatici con mescola Performance sono qualitativamente allineati agli articoli similari prodotti dalla concorrenza asiatica, per questo offrono al bike dilettante ed ambizioso una conveniente alternativa siglata "Continental".

UNE QUALITÉ FIABLE. PureGrip est une technologie mixte issue de la dernière gamme de qualité performance. Son nom des plus éloquentes n'est pas sans évoquer accroche et longévité. Particulièrement solide et adhérent, le mélange de caoutchouc est l'allié idéal de tout cycliste, une caractéristique qui répond ainsi à l'un des objectifs principaux fixés pour le développement de ce produit de la nouvelle usine chinoise de Continental. Grâce à une robuste carcasse en nylon 60 TPI allié à du caoutchouc haute qualité, cette technologie permet une emprise excellente et un colmatage tubeless des pneus à l'aide du RevoSealant "Tubeless Ready" de Conti. La tenue sur la jante est garantie par une tringle souple en aramide. Grâce à ces matériaux de pointe, ces pneus peuvent se mesurer à leurs concurrents asiatiques tout en représentant pour les ambitieux amateurs de vélo une alternative peu onéreuse signée Continental.



URBAN TOUR





CONTACT Speed

UNO PNEUMATICO ALL'ALTEZZA DI OGNI SFIDA, CON LA VELOCITÀ COME PUNTO DI FORZA. Contact Speed è uno slick ad alta tenuta, con battistrada micropuntinato che si distingue particolarmente sull'asfalto. Grazie ad esso le city bike, le single speed e le fitness bike godranno al contempo del suo dinamismo e di un elevato grado di comfort. Oltre che per il particolare battistrada Contact Speed convince per il suo grip, per la sua scorrevolezza e la doppia protezione contro le forature.

ALLIE CONFORT ET VITESSE. Son avantage est la vitesse. Le slick antipatinage avec profil rugueux est particulièrement adapté à l'asphalte. Les vélos de ville, à pignon fixe et d'entraînement profitent de sa dynamique tout en fournissant un grand confort. Ce pneu est ainsi en mesure de relever tous les défis. En plus de son nouveau design Vulcanette, le CONTACT Speed se distingue par son grip, sa fluidité et sa double protection anti-crevaisson.



CONTACT Plus

LA COMBINAZIONE ULTIMA. Un pneumatico polivalente su qualsiasi tipo di strada o percorso che valorizza ogni bicicletta. Grazie all'aggiunta della protezione antiforatura, nessuno rimarrà indietro con una gomma a terra. Insieme alla camera d'aria Hermetic Plus, è un prodotto assolutamente senza preoccupazioni.

LA COMBINAISON ULTIME. Un pneu polyvalent pour tous types de routes ou de chemins qui améliore chaque vélo. Grâce à l'ajout d'une protection contre les crevaisons, personne ne sera laissé avec un pneu à plat. Associé à la chambre à air Hermetic Plus, c'est un produit totalement sans souci.



ARTICLE	EAN	ETRTO	DIMENSION	COLOR/SIDEWALL	TECHNOLOGY	WEIGHT	BAR	MAX.BAR PRICE (€)
CONTACT Speed								
C0101412	4019238774559	37-622	28x1 3/8x1 5/8	black wire skin	Double SafetySystemBreaker	500g	5,0 6,0	32,90
C0101416	4019238774504	42-622	700x42 C (40 C)	black wire skin	Double SafetySystemBreaker	590g	3,5 6,0	32,90
CONTACT Plus								
C0101002	4019238639964	47-559	26x1.75	black reflex wire skin	SafetyPlusBreaker	1040g	3,0 4,0	42,99
C0101004	4019238639940	32-622	28x1 1/4x1 3/4	black reflex wire skin	SafetyPlusBreaker	750g	5,0 6,0	42,99
C0101005	4019238639933	37-622	28x1 3/8x1 5/8	black reflex wire skin	SafetyPlusBreaker	980g	4,0 6,0	42,99
C0101006	4019238639926	42-622	28x1.6	black reflex wire skin	SafetyPlusBreaker	1050g	3,5 5,0	42,99



RIDE Tour

COMPAGNO AFFIDABILE PER IL CICLOTURISMO. Ride Tour è a proprio agio su ogni tipo di fondo, è un vero polivalente. La banda centrale del battistrada ha un design continuo, a garanzia di buone proprietà di rotolamento. Ulteriori punti di forza? L'ampia gamma di colori, di sezioni e la durata elevata.

UN COMPAGNON FIABLE EN RANDONNÉE. Le RIDE Tour est chez lui sur tous les terrains, c'est un véritable multitalent. Sa surface de roulement médiane continue assure de bonnes propriétés de roulement et offre en même temps suffisamment de traction ainsi qu'une grande sûreté dans les virages. Nos clients profitent de la vaste palette de tailles disponibles et de sa grande capacité de kilométrage.



ARTICLE	EAN	ETRTO	DIMENSION	COLOR/SIDEWALL	TECHNOLOGY	WEIGHT	BAR	MAX.BAR	PRICE (€)
RIDE Tour									
C0101148	4019238693553	47-559	26x1.75	black wire skin	Extra Puncture Belt	780g	3,0	4,0	21,99
C0101151	4019238693522	28-622	700x28C (700C)	black wire skin	Extra Puncture Belt	540g	5,0	5,5	21,99
C0101153	4019238693508	32-622	700x32C	black wire skin	Extra Puncture Belt	640g	5,0	5,5	21,99
C0101155	4019238693485	37-622	700x35C	black wire skin	Extra Puncture Belt	690g	4,0	5,0	21,99
C0101157	4019238693478	42-622	700x42C (40C)	black wire skin	Extra Puncture Belt	790g	3,5	4,5	21,99



SafetyPlus Breaker

LO SPECIALISTA TRA I BREAKER

Sviluppato specialmente per le e-bike fino a 50 km/h, combiniamo il nostro SafetySystem Breaker con una gomma ad alta flessibilità. Il risultato è un Breaker estremamente resistente ai tagli e alle perforazioni, con una resistenza al rotolamento sorprendentemente bassa, grazie alla sua elevata elasticità. Questo conserva l'energia e l'inerzia. L'accelerazione rapida così come l'alta velocità di esecuzione delle curve non sono un problema per il Breaker. È lo specialista per le e-bike veloci e per le bici a noleggio.

LE SPÉCIALISTE POUR LES E-BIKES

Pour les E-bikes, nous avons combiné le SafetySystem Breaker avec un matériau hautement élastique. Le résultat est une enveloppe extrêmement résistante aux coupures et aux crevaisons qui, grâce à sa grande élasticité, offre surtout une faible résistance au roulement, économisant la batterie et l'environnement. Il est également conforme aux exigences de plus grande vitesse des E-bikes, pouvant aller jusqu'à 50 km/h. Il est également adapté pour le couple d'accélération plus élevé des vélos électriques ainsi que les vitesses plus rapides dans les virages. Le pneu spécial pour les E-bikes rapides et les vélos de locations.

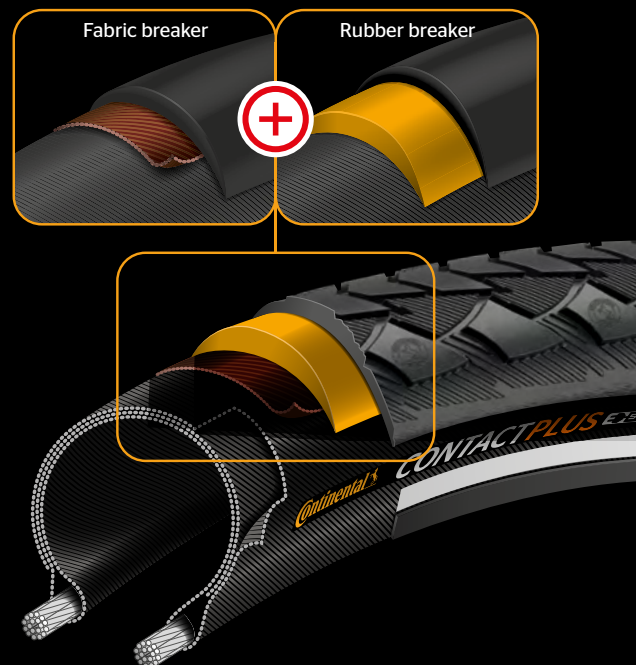

Fino al **30 % in più di maggiore protezione*** contro le perforazioni di sassi e pietre acuminata!

*Test comparativo di resistenza alla foratura (al taglio), Istituto di Zedlere 2016.
Per maggiori informazioni visita <http://www.continental-tires.com/bicycle/technology>

Jusqu'à **30% plus résistant** à l'intrusion de tessons et de silex*

*Test comparatif de résistance aux perforations (lame), Institut Zedler 2016.
Pour plus d'informations, visitez <http://www.continental-tires.com/bicycle/technology>

EXTRA PunctureBelt

Assieme ai fianchi in gomma rinforzata questa fettuccia costituisce un'elevata protezione contro forature e abrasioni. Disponibile in versione di pneumatico compatto con una forte propensione per la durezza.

Tous ceux qui recherchent un compagnon de tous les jours fiable choisiront un pneumatique avec EXTRA PunctureBELT. Ce dispositif de sécurité en caoutchouc robuste, combiné avec les flancs du pneu renforcés de caoutchouc, assure un haut niveau de protection contre les crevaisons et l'abrasion des flancs. Lorsque la longévité est l'objectif principal, il existe également une version pneu plein.

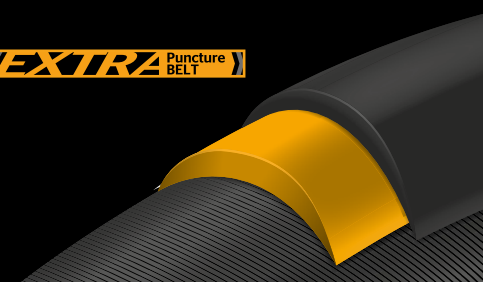

ACCESSORIES



I piccoli dettagli fanno la differenza. Che si tratti di montare lo pneumatico sul cerchio o di riparare una foratura, che sia in strada o nell'officina di casa, le tue coperture necessitano del migliore servizio e del miglior supporto. Nella prossima pagina troverai utili accessori che ti aiuteranno il più possibile a risolvere gli aspetti pratici del tuo sport senza problemi. Dalla giusta camera d'aria ai giusti cerchi passando per gli adeguati levagomme e per i sigillanti efficienti, noi abbiamo sempre qualcosa di utile per il tuo prossimo progetto.

Les petits détails font la différence. Qu'il s'agisse de monter le pneu sur la jante ou d'effectuer de petites réparations, au bord de la route comme à la maison, vous pouvez être sûr que vos pneus bénéficieront du meilleur service et d'une assistance adéquate. Dans la page suivante, vous trouverez des accessoires très utiles pour rendre les aspects techniques de la pratique sportive aussi agréables que possible. Vous cherchez un modèle spécifique, des jantes adaptées à votre vélo, un démonte-pneu pratique ou un produit anti-crevaisson efficace ? Nous avons ce qu'il vous faut!

ARTICLE	EAN	DESCRIPTION	ETRTO	DIMENSION	PRICE (€)
MTB Bicycle Tubes					
C0181631	4019238556711	MTB 26	47-559 > 62-559	S42	8,99
C0182311	4019238619591	MTB 27.5	47-584 > 62-584	S42	8,99
C0180015	4019238008067	MTB 27.5	65-584 > 70-584	S42	10,99
C0182181	4019238557084	MTB 28 / 29 inch	47-622 > 62-662	S42	8,99
C0182191	4019238557091	MTB 28 / 29 inch	47-622 > 62-662	S60	9,99
Tour Bicycle Tubes					
C0182031	4019238556940	Tour 28 all	32-622 > 47-622	S42	8,99
Cross Bicycle Tubes					
C0181941	4019238556872	Cross Tube 28	32-622 > 47-622	S42	8,99
C0181951	4019238556889	Cross Tube 28	32-622 > 47-622	S60	9,99
Race Bicycle Tubes					
C0181781	4019238556780	Race 28	20-622 > 25-630	S42	8,99
C0181791	4019238556797	Race 28	20-622 > 25-630	S60	9,99
C0180000	4024066568133	Race 28	20-622 > 25-630	S80	10,99
C0181821	4019238556803	Race 28 Light	20-622 > 25-630	S42	10,99
C0181831	4019238556810	Race 28 Light	20-622 > 25-630	S60	12,99
C0181871	4019238556827	Race 28 Light	20-622 > 25-630	S80	13,99
C0181881	4019238556834	Race 28 Supersonic	20-622 > 25-630	S42	19,50
C0181891	4019238556841	Race 28 Supersonic	20-622 > 25-630	S60	19,50
C0181921	4019238556858	Race 28 Wide	20-622 > 25-630	S42	8,99
C0181931	4019238556865	Race 28 Wide	20-622 > 25-630	S60	9,99



ARTICLE	EAN	DESCRIPTION	WEIGHT	PRICE (€)
Tubular kit				
C0149091	4019238105322	Rim cement for aluminium	tube 25g	5,50
C0149092	4019238105339	Rim cement for aluminium	can 350g	33,90
C0140016	4024066441405	Rim cement for carbon rims	tube 25g	5,50
C0140017	4024066441412	Rim cement for carbon rims	can 200g	24,90
Tube bag				
C0100388	4024066508061	Tube bag with Race 28 S42 tube and 2 tire lever race	160g	12,99
C0101026	4024066653112	Tube bag with MTB 29 tube S42 and 2 tire levers MTB	320g	12,99
Sealant				
C0140044	4019238558913	Continental RevoSealant	240ml	14,90
C0140050	4019238585278	Continental RevoSealant	1.000ml	38,90
Valve extension				
C0149690	4019238105353	Exchangeable presta valve insert (bag of 10 pcs)	10 pcs	10,00
C0140030	4024066549170	Valve extension for presta valve aluminium 30mm, 2pcs	30mm	14,90
C0140032	4024066549194	Valve extension for presta valve aluminium 40mm, 2pcs	40mm	14,90
C0140034	4024066549217	Valve extension for presta valve aluminium 60mm, 2pcs	60mm	15,90





OVERVIEW

ALL JOURNEYS RANGE



ON ATHLETIC
€ 89,90



ON MODERATE
€ 89,90



ON RELAXED
€ 89,90



NEW

ON OPEN ATHLETIC
€ 89,90



NEW

ON OPEN MODERATE
€ 89,90



NEW

ON OPEN RELAXED
€ 89,90



RESPIRO ATHLETIC
€ 79,90



RESPIRO MODERATE
€ 79,90



RESPIRO RELAXED
€ 79,90



LOOKIN ATHLETIC
€ 69,90



LOOKIN MODERATE
€ 69,90



LOOKIN RELAXED
€ 69,90



LOOKIN EVO ATHLETIC
€ 74,90



LOOKIN EVO MODERATE
€ 74,90



LOOKIN EVO RELAXED
€ 74,90

ADVENTURE TIME RANGE



VAIA ATHLETIC
€ 69,90



VAIA MODERATE
€ 69,90



VAIA RELAXED
€ 69,90



EXPLORA ATHLETIC
€ 69,90



EXPLORA MODERATE
€ 69,90



EXPLORA RELAXED
€ 69,90

URBAN LIFE RANGE



ELLIPSE ATHLETIC
€ 54,90



ELLIPSE MODERATE
€ 54,90



ELLIPSE RELAXED
€ 54,90



FREEWAY FIT ATHLETIC
€ 44,90



FREEWAY FIT MODERATE
€ 44,90



FREEWAY FIT RELAXED
€ 44,90



FLOAT ATHLETIC
€ 44,90



FLOAT MODERATE
€ 44,90



FLOAT RELAXED
€ 44,90

Selle Royal

URBAN LIFE RANGE



AVENUE ATHLETIC
€ 39,90



AVENUE MODERATE
€ 39,90



AVENUE RELAXED
€ 39,90



VIVO ATHLETIC
€ 29,90



DRIFTER STRENGTEX
RELAXED
€ 54,90



DRIFTER PLUS RELAXED
€ 54,90



ONDINA RELAXED
€ 34,90



HOLLAND RELAXED
€ 29,90



WITCH RELAXED
€ 19,90

KIDS SADDLES RANGE



FROGGY / BOY & GIRL
€ 19,90



CANDY / GIRL
€ 19,90



BEN / BOY
€ 19,90



HELLO / BOY & GIRL
€ 19,90

SADDLES BAGS



MEDIUM 1,2L
€ 19,90



LARGE 2,0L
€ 24,90



EXTRA LARGE 7,0L
€ 59,90

SEAT COVERS



ROYALGEL™ SMALL
€ 19,90



ROYALGEL™ LARGE
€ 19,90



SLOW FIT FOAM SMALL
€ 19,90



SLOW FIT FOAM LARGE
€ 19,90

SCIENTIA RANGE



SCIENTIA A1 ATHLETIC
SMALL
€ 89,90



SCIENTIA A2 ATHLETIC
MEDIUM
€ 89,90



SCIENTIA A3 ATHLETIC
LARGE
€ 89,90



SCIENTIA M1 MODERATE
SMALL
€ 89,90



SCIENTIA M2 MODERATE
MEDIUM
€ 89,90



SCIENTIA M3 MODERATE
LARGE
€ 89,90



SCIENTIA R1 RELAXED
SMALL
€ 89,90



SCIENTIA R2 RELAXED
MEDIUM
€ 89,90



SCIENTIA R3 RELAXED
LARGE
€ 89,90

REMED RANGE



REMED SPORT ATHLETIC
€ 26,90



REMED TREKKING MODERATE
€ 26,90



REMED CITY RELAXED
€ 26,90

ROAD SADDLES



VENTO ARGO 00
ADAPTIVE
140mm/150mm
€ 399



VENTO ARGO R1
ADAPTIVE
140mm/150mm
€ 299



VENTO ARGO R3
ADAPTIVE
140mm/150mm
€ 259



VENTO ARGO 00
140mm/150mm
€ 299



VENTO ARGO R1
140mm/150mm
€ 199



VENTO ARGO R3
140mm/150mm
€ 149



VENTO ARGO R5
140mm/150mm
€ 109



TEMPO ARGO R1
150mm/160mm
€ 199



TEMPO ARGO R3
150mm/160mm
€ 149



TEMPO ARGO R5
150mm/160mm
€ 109



VENTO ANTARES 00
140mm/150mm
€ 299



VENTO ANTARES R1
140mm/150mm
€ 199



VENTO ANTARES R3
140mm/150mm
€ 149



VENTO ANTARES R5
140mm/150mm
€ 109



TEMPO ALIANTE R1
145mm/155mm
€ 199



TEMPO ALIANTE R3
145mm/155mm
€ 149



TEMPO ALIANTE R5
145mm/155mm
€ 109



ARIONE 00
€ 299



ARIONE R1
126mm/140mm
€ 199



ARIONE R3
126mm/140mm
€ 149



ARIONE CLASSIC
€ 129



ARIONE R1 OPEN
132mm/142mm
€ 199



ARIONE R3 OPEN (Black)
132mm/142mm
€ 149



ARIONE R3 OPEN (White)
132mm/142mm
€ 149

TRIATHLON SADDLES



TRANSIRO AERIS LD R1
€ 199



TRANSIRO AERIS LD R3
€ 149



TRANSIRO AERIS LD R5
€ 109



TRANSIRO AERIS SD R1
€ 199



TRANSIRO AERIS SD R3
€ 149



TRANSIRO AERIS SD R5
€ 109

OFF-ROAD SADDLES



VENTO ARGO X1
140mm/150mm
€ 199



VENTO ARGO X3
140mm/150mm
€ 149



VENTO ARGO X5
140mm/150mm
€ 109



TERRA ARGO X1
140mm/150mm/160mm
€ 199



TERRA ARGO X3
140mm/150mm/160mm
€ 149



TERRA ARGO X5
140mm/150mm/160mm
€ 109



TERRA ALPACA X5
+ CARRIAGE KIT
€ 109



GRAVITA ALPACA X5
+ CARRIAGE KIT
€ 99



TERRA AIDON X1
145mm/160mm
€ 179



TERRA AIDON X3
145mm/160mm
€ 139



TERRA AIDON X5
145mm/160mm
€ 89

ROAD SHOES



VENTO INFINITO KNIT
CARBON 2
Black/Black
€ 380



VENTO INFINITO KNIT
CARBON 2
Coral/Black
€ 380



VENTO INFINITO
CARBON 2
Black/Black
€ 380



VENTO INFINITO
CARBON 2
White/Black
€ 380



VENTO INFINITO
CARBON 2
Grey/Coral**
€ 380



NEW

VENTO POWERSTRAP
AEROWEAVE CARBON
White/White
€ 350



NEW

VENTO POWERSTRAP
AEROWEAVE CARBON
Coral/Orange
€ 350



TEMPO DECOS CARBON
Aubergine
€ 290



TEMPO DECOS CARBON
Black/Black
€ 290



TEMPO DECOS CARBON
Iridescent Blue
€ 290



TEMPO DECOS CARBON
White/White
Available also in WIDE version
€ 290



VENTO OMNA
Black/Black
€ 165



VENTO OMNA
White/Black
Available also in WIDE version
€ 165



VENTO OMNA
Red/Black
€ 165



VENTO OMNA
Metallic Gun Metal/Black
€ 165



VENTO OMNA
Cherry/Black
€ 165



TEMPO OVERCURVE R4
White/Black
€ 219



TEMPO OVERCURVE R4
Navy/Black
€ 219



TEMPO OVERCURVE R4
Black/Black
Available also in WIDE version
€ 219



TEMPO OVERCURVE R4
Copper/Black Iridescent
€ 219



TEMPO OVERCURVE R4
Beetle/Black Iridescent
€ 219



TEMPO OVERCURVE R5
Black/Black**
€ 119



TEMPO OVERCURVE R5
White/Black**
€ 119



TEMPO OVERCURVE R5
Black/Pink Fluo**
€ 119



TEMPO OVERCURVE R5
Black/Yellow Fluo**
€ 119



TEMPO OVERCURVE R5
Metallic Gun Metal/Black**
€ 119



TEMPO POWERSTRAP R5
Black/Black
€ 139



TEMPO POWERSTRAP R5
White/Black
€ 139



TEMPO POWERSTRAP R5
Reflective Grey/Black
€ 149

ROAD SHOES



TEMPO ARTICA R5 GTX
Black/Black
€ 259



TEMPO ARTICA R5 GTX
White/Grey
€ 259

TRIATHLON SHOES



TRANSIRO HYDRA
AEROWEAVE CARBON
White/Silver
€ 290



TRANSIRO HYDRA
AEROWEAVE CARBON
White/Red-Blue
€ 290



TRANSIRO HYDRA
White/Black
€ 149



TRANSIRO HYDRA
White/Metallic Red
€ 149



TRANSIRO HYDRA
White/Metallic Blue
€ 149

OFF-ROAD SHOES



VENTO FEROX CARBON
Black/Black
€ 299



VENTO FEROX CARBON
Lilac/White
€ 299



NEW

VENTO PROXY
Black/Black
€ 229



NEW

VENTO PROXY
Coral/Purple
€ 229



NEW

VENTO PROXY
White/White
€ 229



TERRA ATLAS
Grey/Black
€ 159



TERRA ATLAS
Black/Black
€ 159



TERRA ATLAS
Army
€ 159



TERRA ATLAS
Pink Grape
€ 159



TERRA ATLAS
Black/Splash Purple
Limited edition
€ 159



TERRA ATLAS
Green/Splash Pink
Limited edition
€ 159



VENTO OVERCURVE X3
Black/Black**
€ 229



VENTO OVERCURVE X3
White/Black**
€ 229

(**) Fino ad esaurimento scorte | Jusqu'à épuisement des stocks

OFF-ROAD SHOES



TERRA POWERSTRAP X4
Mud/Caramel
€ 159



TERRA POWERSTRAP X4
Black/Black
€ 159



TERRA CLIMA X2
Black/Black
€ 250



TERRA ERGOLACE X2
Teal Blue/Black
€ 129



TERRA ERGOLACE X2
Olive/Caramel
€ 129



TERRA ERGOLACE X2
Black/Black
Available also in FLAT version
€ 129



GRAVITA TENSOR
Black/Black
Available also in FLAT version
€ 179



GRAVITA VERSOR
Grey/Mud
Available also in FLAT version
€ 139

GORE-TEX SHOES



TERRA ERGOLACE X2 GTX
Ice Grey/Black
€ 189



TERRA ERGOLACE X2 GTX
Anthracite/Black
€ 189



TERRA ARTICA X5 GTX
Black/Black
€ 259



TERRA ARTICA X5 GTX
Purple/Black
€ 259

VENTO MICROTEX TACKY BARTAPES (Thickness 2mm)



Black € 40,90 White € 40,90 Red € 40,90 Orange Fluo € 40,90 Pink Fluo € 40,90 Yellow Fluo € 40,90 Lilla Fluo € 40,90 Celeste € 40,90



Black/Celeste € 43,90 Black/White € 43,90 Black/Red € 43,90 Black/Grey € 43,90

VENTO SOLOCUSH TACKY BARTAPES (Thickness 2,7mm)



Black € 43,90 White € 43,90 Blue € 43,90 Green € 43,90 Red € 43,90 Pink € 43,90 Yellow € 43,90 Orange Fluo € 43,90



Pink Fluo € 43,90 Yellow Fluo € 43,90 Lilla Fluo € 43,90 Celeste € 43,90 Mint Green € 43,90 Light Grey € 43,90 Dark Grey € 43,90

TEMPO MICROTEX CLASSIC BARTAPES (Thickness 2mm)



Black € 23,90 White € 23,90 Blue € 23,90 Green € 23,90 Red € 23,90 Pink € 23,90 Yellow € 23,90 Orange € 23,90



Honey € 23,90 Silver € 23,90 Celeste € 23,90

TEMPO MICROTEX BOND CUSH BARTAPES (Thickness 3mm)



Black € 30,90 White € 30,90 Honey € 30,90

TEMPO MICROTEX BOND CUSH SOFT BARTAPE (Thickness 3mm)



Black € 30,90 Red € 30,90

TEMPO MICROTEX BOND CUSH TACKY BARTAPE - Les Classiques (Thickness 3mm)



Le Classiques - Limited Edition € 43,90

TERRA MICROTEX BOND CUSH TACKY BARTAPES (Thickness 3mm)



Black € 43,90 White € 43,90 Red € 43,90 Dark Blue € 43,90 Green/Blue € 43,90 Brown € 43,90 Light Grey € 43,90

(**) Fino ad esaurimento scorte | Jusqu'à épuisement des stocks



MALLET PEDALS



MALLET DH 11
Black/Gold
€ 350



MALLET DH RACE
Black/Black
€ 180



MALLET DH RACE
Red/Red
€ 180



MALLET E 11
Black/Gold
€ 350



MALLET E
Black/Black
€ 180



MALLET E
Electric Blue/Blue
€ 180



MALLET E LS
Blue/Black**
€ 180



MALLET E LS
Silver/Black**
€ 180



MALLET E LS
Lime Green/Black/Black**
Splatter edition
€ 180



MALLET E LS
Blue/Black/Black**
Splatter edition
€ 180



MALLET TRAIL
Black/Black
€ 180



MALLET TRAIL
Champagne/Black
€ 180



MALLET TRAIL
Purple/Black
€ 180



MALLET 3
Raw/Black/Blue
€ 150



MALLET 3
Raw/Red/Red**
€ 150



MALLET 2
Raw/Green/Black**
€ 100



MALLET 2
Raw/Silver/Black
€ 100



CANDY PEDALS



CANDY 11
Gold/Gold
€ 500



CANDY 7
Black/Electric Blue/Black
€ 180



CANDY 7
Black/Black
€ 180



CANDY 7
Red/Red
€ 180



CANDY 3
Black/Black
€ 150



CANDY 3
Dark Red/Red**
€ 150



CANDY 3
Slate Blue/Blue
€ 150



CANDY 2
Dark Grey/Black
€ 100



CANDY 2
Red/Black
€ 100



CANDY 1
Black/Black
€ 60



CANDY 1
Light Blue/Blue
€ 60



CANDY 1
Red/Red
€ 60



CANDY 1
Pink/Pink
€ 60



EGGBEATER PEDALS



EGGBEATER 11
Gold/Gold
€ 500



EGGBEATER 3
Light Blue/Electric Blue
€ 150



EGGBEATER 3
Red/Red
€ 150



EGGBEATER 3
Black/Black
€ 150



EGGBEATER 2
Black/Black
€ 100



EGGBEATER 2
Black/Green
€ 100



EGGBEATER 1
Silver/Red
€ 60



EGGBEATER 1
Silver/Black
€ 60

DOUBLE SHOT PEDALS



DOUBLE SHOT 3
Black/Black
€ 150



DOUBLE SHOT 3
Red/Black/Black
€ 150



DOUBLE SHOT 2
Black/Silver/Blue
€ 100



DOUBLE SHOT 2
Orange/Black/Orange
€ 100



DOUBLE SHOT 2
Blue/Black/Black
€ 100



DOUBLE SHOT 1
Black/Black
€ 60



DOUBLE SHOT 1
Blue/Black
€ 60



DOUBLE SHOT 1
Red/Black
€ 60



STAMP PEDALS



STAMP 11 - Small/Large
Black/Gold
€ 300



STAMP 7 - Small/Large
Black
€ 180



STAMP 7 - Small/Large
Red
€ 180



STAMP 7 - Small/Large
Electric Blue
€ 180



STAMP 7 - Small/Large
High Polish Silver
€ 190



STAMP 7 - Small/Large
Lime Green**
Splatter edition
€ 180



STAMP 7 - Small/Large
Red**
Splatter edition
€ 180



STAMP 7 - Small
Blue**
Splatter edition
€ 180



STAMP 3 - Small/Large
Black Magnesium
€ 140



STAMP 3 - Small/Large
Silver Magnesium
€ 140



STAMP 2 - Small/Large
Raw Silver
€ 100



STAMP 2 - Small/Large
Black
€ 100



STAMP 1 - Small/Large
Black
€ 50



STAMP 1 - Small/Large
Red
€ 50



STAMP 1 - Small/Large
Blue
€ 50



STAMP 1 - Small/Large
Orange
€ 50



NEW

STAMP 1 GEN 2
Small/Large
Black
€ 60



NEW

STAMP 1 GEN 2
Small/Large
Red
€ 60



NEW

STAMP 1 GEN 2
Small/Large
Orange
€ 60



NEW

STAMP 1 GEN 2
Small/Large
Navy Blue
€ 60



NEW

STAMP 1 GEN 2
Small/Large
Purple
€ 60

(**) Fino ad esaurimento scorte | Jusqu'à épuisement des stocks



MALLET TRAIL SHOES



NEW

MALLET TRAIL BOA
Black/Gold
€ 220



NEW

MALLET TRAIL LACE
Black/Black
€ 170



NEW

MALLET TRAIL LACE
White/Purple
€ 170



NEW

MALLET TRAIL LACE
Blue/Blue
€ 170

STAMP TRAIL SHOES



NEW

STAMP TRAIL BOA
Black/Gold
€ 200



NEW

STAMP TRAIL LACE
Black/Black
€ 150



NEW

STAMP TRAIL LACE
White/Purple
€ 150



NEW

STAMP TRAIL LACE
Blue/Blue
€ 150

MALLET SHOES



MALLET BOA
Black/Gold
€ 200



MALLET SPEEDLACE
Black/White
€ 170



MALLET LACE
Black/Red
€ 150



MALLET LACE
Red/Black**
PumpForPeace edition
€ 160



MALLET LACE
Grey/Blue**
Splatter edition
€ 150



MALLET LACE
Petrol/Lime**
Splatter edition
€ 150

MALLET E SHOES



MALLET E BOA
Black/Gold**
€ 200



MALLET E SPEEDLACE
Green/Blue**
€ 170



MALLET E LACE
Black/Blue**
€ 150



STAMP SHOES



STAMP BOA
Black/Gold
€ 180



STAMP SPEEDLACE
Black/White
€ 150



STAMP SPEEDLACE
Purple/Teal Blue
€ 150



STAMP SPEEDLACE
Green/Orange**
€ 150



STAMP SPEEDLACE
Grey/Red***
€ 150



STAMP LACE
Black/Silver
€ 130



STAMP LACE
White/White
€ 130



STAMP LACE
Navy/Silver
€ 130



STAMP LACE
Red/Black**
PumpForPeace edition
€ 140



STAMP LACE
Grey/Blue**
Splatter edition
€ 130



STAMP LACE
Petrol/Lime**
Splatter edition
€ 130

STAMP STREET SHOES



STAMP STREET LACE
Black/Gold
€ 130



STAMP STREET LACE
White/Gold
€ 130

CANDY GRAVEL/XC SHOES



CANDY GRAVEL / XC LACE
Black/Black
€ 160



CANDY GRAVEL / XC LACE
White/Grey
€ 160

(**) Fino ad esaurimento scorte | Jusqu'à épuisement des stocks



ALLOY WHEELS



SYNTHESIS XCT ALLOY
Alloy Single Wheel
€ 240 front / € 360 rear

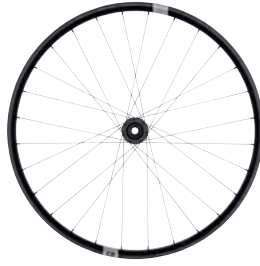

SYNTHESIS E ALLOY
Alloy Single Wheel
€ 240 front / € 360 rear



SYNTHESIS E-BIKE ALLOY
Alloy Single Wheel
€ 300 front / € 400 rear



NEW

SYNTHESIS GRAVEL
Alloy Single Wheel
€ 240 front / € 360 rear



COBALT 2
Alloy Wheelsets
€ 600



IODINE 2
Alloy Wheelsets
€ 600



ZINC 3
Alloy Wheelsets
€ 800

CARBON WHEELS



SYNTHESIS XCT 11
Carbon Wheelsets
€ 2.400



SYNTHESIS E 11
Carbon Wheelsets
€ 2.400



NEW

SYNTHESIS GRAVEL
Carbon Single Wheel
€ 600 front / € 900 rear

GRIPS



COBALT
Silver
€ 30



COBALT
Gold
€ 30



COBALT
Red
€ 30



IODINE
Black
€ 30



DROPPER SEATPOST



HIGHLINE 11
100/125/150/170 mm
€ 400



HIGHLINE 7
100/125/150/170/200 mm
€ 300



HIGHLINE 3
80/100/125/150/170/200 mm
€ 200



HIGHLINE XC/GRAVEL
60/80/100/125 mm
€ 250

A4 SALES AGENTS

FRANCE

REGION NORD

(Haut De France / Ile de France / Haute Normandie / Champagne Ardennes / Centre)

Max Vanovershelde

M +33 662121870

maxvano59@gmail.com

REGION OUEST

(Bretagne / Basse Normandie / Pays de Loire / Poitou Charentes)

Gilles Cosperec

M +33 668698366

gsports@hotmail.fr

REGION SUD OUEST

(Aquitaine / Midi Pyrennées / Languedoc Roussillon / Limousin)

Vincent Guezennec

M +33 0614981632

vincent.guezennec@outlook.fr

REGION SUD EST

(Provence Alpes Côte d'Azur / Corse / Rhône Alpes / Auvergne / Suisse)

Pierre Bajoux

M +33 699321434

pierrebajoux@gmail.com

REGION EST

(Alsace / Lorraine / Franche Comté / Bourgogne)

Patrick Ledys

M +33 607140471

p.ledys@alecar-sports.com

SALES AREA MANAGER

Terigi Synowiec

M +33 607708217

terigi.synowiec@selleroyalgroup.com

SUISSE ROMANDE

VAUD / VALAIS / NEUCHÂTEL / GENEVE / JURA / FRIBOURG

Pierre Bajoux

M +33 699321434

pierrebajoux@gmail.com

SALES AREA MANAGER

Terigi Synowiec

M +33 607708217

terigi.synowiec@selleroyalgroup.com

COPYRIGHT. Tous les contenus du présent catalogue, y compris les textes, documents, logos, images, graphiques, vidéos, leur propre disposition et adaptation à l'intérieur du site, sont protégés suivant les lois du Copyright© de Selle Royal Group S.p.A. et des autres droits de la propriété intellectuelle. La reproduction, altération, modification, publication et l'utilisation, même partielle de ces contenus, quel qu'en soit l'usage, soit commercial ou non, dans tout type de format et support, ne sont pas permis sans l'autorisation expresse écrite de Selle Royal Group S.p.A. Tous les droits sont réservés.

MARQUES. Toutes les marques et logos présents dans le catalogue sont la propriété exclusive de leurs détenteurs respectifs. Toute utilisation et/ou reproduction de ceux-ci pour n'importe quel but ou moyen sont strictement et sévèrement interdits et entraîneront des poursuites suivant les lois applicables en la matière.

LIMITES DE RESPONSABILITÉ. Les contenus et les informations présents dans le catalogue sont fournis "en l'état" et périodiquement mis à jour et contrôlés. En conséquence, ils pourraient s'avérer incomplets, imprécis ou mis à jour à tout moment, ou contenir des erreurs. Selle Royal Group S.p.A. décline toute responsabilité et toute garantie concernant l'exactitude, la mise à jour, erreurs et omissions des informations et des contenus présents dans le catalogue.



BUREAU COMMERCIAL/ADMINISTRATIF

Selle Royal Group S.p.A.
Via Vittorio Emanuele 119
36050 Pozzoleone (VI) Italy

CONTACTS

T +39 0444 461100
T +39 0444 461102
info@a4selection.com
www.a4selection.com

RÉCLAMATIONS ET RETOURS

info@a4selection.com
(per ricevere autorizzazione al reso e relative istruzioni)

SERVICE APRÈS VENTE CRANKBROTHERS

Pippo Wheels S.r.l.
Via S. Venier 15
36100 Vicenza (VI) Italy
T +39 0444 532052
crankbrothers@pippowheels.com

GARANTIE

Les articles présentés dans ce catalogue sont couverts par **2 ANNÉES** de garantie à compter de la date d'achat

Selle Royal

SELLEROYAL.COM

fi'zi:k

FIZIK.COM



crankbrothers

CRANKBROTHERS.COM

Continental 

CONTINENTAL-TIRES.COM

A4SELECTION.COM

