

# SELECTION

2024

**WORKBOOK 2024**

A SELECTION OF THE BEST CYCLING  
COMPONENTS AND ACCESSORIES

Selle Royal

fi'zi:k

  
crankbrothers

 Continental

**BR@KS**  
18 ENGLAND 66



## **WORKBOOK 2024**

<b>SELLE ROYAL</b>	<b>5</b>
<b>FIZIK</b>	<b>51</b>
<b>CRANKBROTHERS</b>	<b>151</b>
<b>CONTINENTAL</b>	<b>227</b>
<b>BROOKS ENGLAND</b>	<b>263</b>
<b>OVERVIEW</b>	<b>339</b>

# Selle Royal





**SELLE ROYAL**

## Product categories



### All Journeys Riding Everywhere

These best-in-class Selle Royal products are adaptable and perfect for those who don't want to compromise on excellence – both in the city or adventuring outdoors. With the All Journeys range, premium materials and innovative technologies result in the ultimate in comfort, striking design and durability.

Diese Spitzenprodukte von Selle Royal sind anpassungsfähig und perfekt für alle, die keine Kompromisse bei der Qualität eingehen wollen - sowohl in der Stadt als auch bei Abenteuern in der Natur. In der All Journeys Serie sorgen hochwertige Materialien und innovative Technologien für ultimativen Komfort, markantes Design und Langlebigkeit.



### Adventure Time Exploring Outdoors

A breath of fresh air for all excursions. No matter if you ride for fun, fitness or touring far away: this range of saddles gives its best to help you enjoy your free time on the bike. All these models are suitable for long rides and different types of terrain – so you can explore the wilds to your heart's content.

Frischer Wind auf allen Ausflügen. Egal, ob Sie zum Vergnügen, für die Fitness oder auf einer Fernreise unterwegs sind: Diese Sattelreihe gibt alles, damit Sie Ihre freie Zeit auf dem Rad genießen können. Alle Modelle eignen sich für lange Fahrten und unterschiedliche Bodenbeschaffenheiten - damit Sie die Natur nach Lust und Laune erkunden können.



### Urban Life Moving in the City

Ultimate comfort for cycling in the city. Any saddle belonging to this range will become your trusted companion for everyday life. From short rides to long commutes, from modern style to high reliability, select from many models according to your needs in the city.

Ultimativer Komfort für das Radfahren in der Stadt. Jeder Sattel aus diesem Sortiment wird zu Ihrem zuverlässigen Begleiter im Alltag. Von kurzen Fahrten bis zu langen Pendelstrecken, über einen modernem Stil bis zu hoher Zuverlässigkeit, wählen Sie aus vielen Modellen entsprechend Ihren Anforderungen in der Stadt.

# New packaging

New logo

Neues Logo

The saddle introduces itself

Der Sattel stellt sich hier vor

Product key benefits are clearly and concisely highlighted

Die wichtigsten Produkteigenschaften werden klar und übersichtlich hervorgehoben

The product range defines the saddle use to guide the consumer to the right saddle choice

Die Produktpalette definiert den Anwendungsbereich des Sattels um den Endverbraucher bei der Wahl des richtigen Sattels zu unterstützen



The riding position is clearer and easier to understand  
Die Sitzposition ist eindeutiger und leichter zu interpretieren

30-Day Comfort Guarantee highlighted on the front  
Die 30 Tage Komfort-Garantie wird auf der Vorderseite optisch hervorgehoben

New colours for new ranges  
Neue Farben für neue Kategorien

Package can be opened to include more product information

Die Verpackung kann geöffnet werden, um weitere Produktinformationen zu erhalten

Explanation of the saddle's key benefits and the reusable product features

Erläuterung der wesentlichen Merkmale des Sattels und der weiteren Produktmerkmale



New texts in 6 languages, with an easier and more engaging copy  
Überarbeitete Texte in 6 Sprachen, mit einer einfacheren und ansprechenderen Darstellung

Explanation of the riding position concept and the unisex approach

Erläuterung des Sitzkonzepts und des Unisex-Ansatzes

Indications of sustainability and recycling: packaging made from 100% recycled and recyclable paper

Hinweise auf Nachhaltigkeit und Recycling: Verpackung aus 100% recyceltem und recyclingfähigem Papier

Indication of Made in Italy

Hinweis auf Made in Italy

# Riding positions

Riding position is the crucial factor in choosing the optimal saddle. According to your riding style, the way your sit bones rest on the saddle varies substantially and this consequently affects the level of comfort. Selle Royal saddles are ergonomically designed to fit all ischial bones widths and satisfy the anatomical needs of both men and women, guaranteeing pressure relief in the most sensitive areas.

Select your correct riding position among **45° (Athletic)**, **60° (Moderate)** and **90° (Relaxed)** to enjoy your rides pain-free!

Die Fahrposition ist der entscheidende Faktor bei der Wahl des optimalen Sattels. Je nach Fahrstil variiert die Art und Weise, wie Ihre Sitzknochen auf dem Sattel aufliegen erheblich und beeinflusst somit den Komfort. Selle Royal Sättel sind ergonomisch auf die unterschiedlichen Sitzknochenabstände abgestimmt, um die anatomischen Anforderungen von Männern und Frauen zu erfüllen und so eine Druckentlastung der empfindlichsten Bereiche zu garantieren.

Wählen Sie Ihre richtige Sitzposition zwischen **45° (Athletic)**, **60° (Moderate)** und **90° (Relaxed)**, um Ihre Ausflüge schmerzfrei zu genießen!

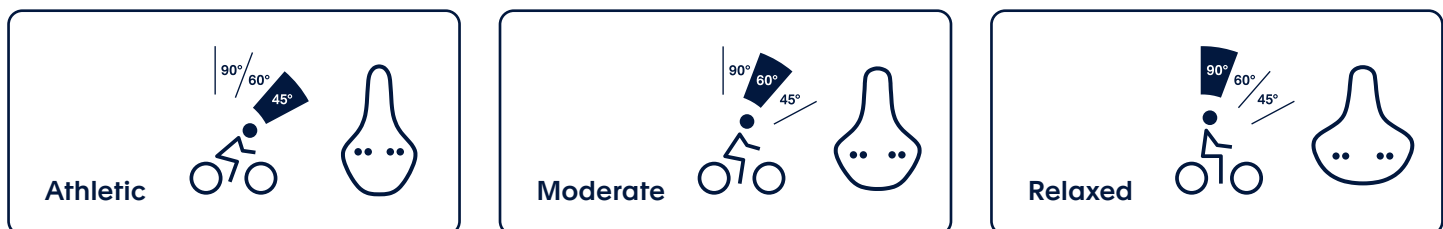

## 30 Day Comfort Guarantee

Selle Royal offers a 30-day Comfort Guarantee on all products.

The new packaging also clearly displays this information on the front: make sure you properly inform your customers about this benefit so they can take advantage!

Selle Royal bietet eine 30-Tage-Komfort-Garantie auf alle Produkte.

Auch auf der neuen Verpackung ist diese Information deutlich auf der Vorderseite zu lesen: Informieren Sie Ihre Kunden über diese Möglichkeit, sodass sie die Vorteile auch nutzen können!





# Product features

## Royal Comfort



### ROYALGEL™

Superior to any other padding material for its unique formulation, Royalgel™ provides the highest level of comfort. Durable and versatile, this technology absorbs pressure and distributes it across the saddle surface, ensuring the best support for even your longest rides.

Durch seine einzigartige Zusammensetzung übertrifft Royalgel™ jedes andere Polstermaterial und bietet höchsten Komfort: Langlebig und vielseitig, diese Technologie absorbiert den Druck und verteilt ihn über die Satteloberfläche und sorgt für die richtige Unterstützung, auch bei längeren Fahrten.

## Immediate Comfort



### SLOW FIT FOAM

Ideal for short and easy rides, Slow Fit Foam is an exclusive Selle Royal technology designed to fit the shape of your body. Its memory foam formulation with a slow, bounce-back effect provides immediate comfort and ensures a smooth feeling while riding.

Der Slow Fit Foam ist eine exklusive Technologie von Selle Royal, die sich der Körperform anpasst und ideal für kurze und entspannte Fahrten ist. Dank des Memory Schaums mit einem langsamen Rückfederungseffekt bietet er sofortigen Komfort und sorgt für ein ausgeglichenes Fahrgefühl.

## Firm Comfort



### FOAM MATRIX

Robust yet flexible for everyday rides. If you're looking for firm and solid support during your short and easy trips, a saddle with Foam Matrix padding is the answer.

Robust und doch flexibel für die täglichen Fahrten. Wenn Sie einen festen und soliden Halt bei Ihren kurzen und gemütlichen Fahrten suchen, sind Sie mit einem Sattel mit Foam Matrix-Polsterung gut beraten.

## Extreme Durability



### UNITECH

With padding and cover all in one piece, saddles with Unitech technology are designed to last, being highly resistant to abrasion as well as waterproof. This means that you don't need to worry about exposing your saddle to the elements, or the dangers of the city.

Mit Polster und Satteldecke aus einem Stück, sind Sättel mit Unitech-Technologie auf Langlebigkeit ausgelegt, da sie sowohl abriebfest als auch wasserdicht sind. Das bedeutet, dass Sie sich keine Sorgen machen müssen, wenn Ihr Sattel den Elementen oder den Tücken der Großstadt ausgesetzt ist.

## Waterproofness



### ROYAL VACUUM

Enjoy a dry ride with a water-resistant saddle. This patented Selle Royal technology allows the saddle to be 100% sealed and substantially waterproof, even when exposed to heavy, wet weather.

Diese von Selle Royal patentierte Technologie gewährleistet, dass der Sattel zu 100 % geschlossen und somit wasserdicht ist, selbst wenn er starkem Regen oder extrem nasser Witterung ausgesetzt ist.

## Fresh Seat



### COOL COVER

This special cover composition reflects sunlight to keep your saddle 25°C cooler than a standard black saddle – so you can leave your bike in the sun without thinking twice.

Der spezielle Oberflächenbezug reflektiert das Sonnenlicht, so dass Ihr Sattel 25°C kühler bleibt als ein schwarzer Standardsattel – so können Sie Ihr Fahrrad ohne Bedenken in der Sonne stehen lassen.

## Perineal Ventilation



### VENTILATION CHANNEL

Don't let overheating spoil your ride: the ventilation function allows for air to flow through your saddle via an anatomically designed cut-out, ensuring a non-sweaty, breezy feeling while cycling. Designed for cool rides and reduced pressure in the perineal area.

Lassen Sie sich Ihre Fahrt nicht durch eine übermäßige Wärmeentwicklung verderben: Die Belüftungsfunktion lässt die Luft über einen anatomisch geformten Ausschnitt durch den Sattel strömen und sorgt so für ein schweißfreies, luftiges Gefühl beim Radfahren. Entwickelt für angenehmes temperiertes Fahren und reduzierten Druck im Dammbereich.

## Perineal Relief



### ERGONOMIC HOLE

An ergonomic central cut-out designed to relieve pressure in the perineal area, making it ideal for the most sensitive riders. No pain, just gain on your rides!

Eine ergonomische Aussparung in der Mitte, die den Druck im Dammbereich reduziert und somit auch für die empfindlichsten Fahrer geeignet ist. Ohne Schmerzen, dafür mit mehr Spaß auf Ihren Fahrten!



### ERGONOMIC CHANNEL

This indent is designed to ergonomically follow the shape of the body, delivering pressure relief in the soft tissue areas and support in the ischiatic zone. No pain, just gain on your rides!

Diese Aussparung ist so konzipiert, dass sie ergonomisch der Form des Körpers folgt und eine Druckentlastung in den Weichteilbereichen und eine Unterstützung in der ischiatischen Zone bietet. Keine Schmerzen, dafür mehr Spaß auf Ihren Fahrten!

## High Resistance



### STRENGTEX

This is an ultra-resistant cover material made to accompany the tough life of any saddle. Thanks to its multi-layer structure, your Strengetex saddle doesn't fear punctures, cuts, tears, cracks or aging and it is thus perfect for the urban jungle.

Ein extrem widerstandsfähiges Deckmaterial, das das harte Leben eines jeden Sattels mitmacht. Dank des mehrschichtigen Aufbaus hat Ihr Strengetex-Bezug keine Angst vor Einstichen, Schnitten, Rissen oder Alterung und ist damit perfekt geeignet für den Großstadtdschungel.

## Shock Absorption



### FLEXITE SYSTEM

Maximised flexibility and shock absorption are provided by the unique indented construction of the shell, ensuring smooth rides across town or into the wild.

Maximale Flexibilität und Stoßdämpfung werden durch die einzigartige, vorgeformte Schalenkonstruktion gewährleistet und sorgen für reibungslose Fahrten in der Stadt oder der Natur.



### THERMOPLASTIC DAMPER

Working like an elastomer, the Thermoplastic Damper positioned at the rear of the saddle will smooth out bumpy rides, silently absorbing even the most severe shocks.

Der thermoplastische Dämpfer im hinteren Teil des Sattels wirkt wie ein Elastomer und fängt selbst starke Stöße geräuschlos ab.



### ELASTOMERS

You always watch out for unexpected obstacles, but if you do miss one, your saddle with elastomers will absorb even the most severe shocks without making a sound.

Sie achten immer auf unerwünschte Stolperfallen aber wenn Sie dann doch mal eine übersehen haben, fängt Ihr Sattel mit Elastomeren auch die stärksten Stöße ab und das völlig geräuschlos.



### CUPSPRINGS

You always watch out for unexpected obstacles, but if you do miss one, your saddle with cup springs will absorb even the most severe shocks without making a sound.

Sie haben immer ein Auge auf unerwartete Stolpersteine, aber wenn Sie doch mal einen übersehen, fängt Ihr Sattel mit Cup Spring auch die stärksten Stöße ab, ohne ein Geräusch zu machen.

## Safe Sides



### DOUBLE-COVER SIDE PROTECTION

Say no to scuffed saddle sides and lean your bike against anything in total freedom: the double-layer material applied to the sides of the saddle increases resistance against impacts and abrasions.

Sagen Sie "Nein" zu aufgescheuerten Sattelseiten und lehnen Sie Ihr Fahrrad völlig unbeschwert an: Das doppellagige Material, das an den Sattelflanken angebracht ist, erhöht die Widerstandsfähigkeit gegen Stöße und Abschürfungen.



### SCUFF GUARDS

Say no to scuffed saddle sides and lean your bike against anything in total freedom: the extra protective inserts applied to the sides of the saddle increase resistance against impacts and abrasions.

Sagen Sie "Nein" zu aufgescheuerten Sattelseiten und lehnen Sie Ihr Fahrrad völlig unbeschwert an: Die zusätzlichen Schutzeinlagen an den Seiten des Sattels erhöhen die Widerstandsfähigkeit gegen Stöße und Abschürfungen.

## Safety at Night



### REFLECTIVE FILM

Either riding in town or exploring the wilderness, it's paramount to always be seen by cars, bicycles and other vehicles. If, or rather when, your rear light fails you, for an extra dose of safety this reflective film will have your back.

Ob Sie in der Stadt fahren oder die Umgebung erkunden, wichtig ist, dass Sie immer von Autos, Radfahrern und anderen Verkehrsteilnehmern gesehen werden. Sollte Ihr Rücklicht Sie im Stich lassen, sorgt diese reflektierende Folie für zusätzliche Sicherheit.

## Spring Suspension



### DOUBLE SPRINGS

Striking look and excellent suspension, all in one: the standard springs have evolved to improve suspension performance while retaining that classic allure so you don't have to compromise on style – or bounce.

Auffälliger Look und exzellente Federung in einem: Die Standardfedern wurden weiterentwickelt, um die Federungsleistung zu verbessern und gleichzeitig den klassischen Charme beizubehalten, sodass Sie keine Kompromisse beim Stil - oder beim Federungskomfort - eingehen müssen.



### SPRINGS

Sometimes older is better: springs add great suspension and a touch of class to any bike.

Manchmal ist alt einfach besser: Federn verleihen jedem Fahrrad eine ausgezeichnete Dämpfung und gleichzeitig einen klassischen Touch.

## Clip & Go



### INTEGRATED CLIP SYSTEM

A must for your Selle Royal accessories: the Integrated Clip System positioned at the rear of your saddle will make the attachment of a Selle Royal saddle bag or other accessories an easy clip away.

Ein Muss für Ihr Selle Royal-Zubehör: Mit dem integrierten Clip-System, das an der Rückseite Ihres Sattels angebracht ist, können Sie eine Selle Royal-Satteltasche oder anderes Zubehör ganz einfach per Clip befestigen.



### MULTI-TOOL

Always be prepared for the unexpected. This multi-tool attaches to the rear of your Selle Royal saddle equipped with the Integrated Clip System (ICS) to always be on hand for quick adjustments and repairs on the road. Protected by an anti-shock rubber housing, this compact and secure package offers 9 tools for years of reliable use.

Dieses Multitool lässt sich an der Rückseite Ihres mit dem Integrated Clip System ausgestatteten Selle Royal Sattels befestigen und ist so für spontane Anpassungen und Reparaturen unterwegs immer griffbereit. Durch ein stoßfestes Gummigehäuse geschützt, beinhaltet dieses kompakte und zugleich robuste Gesamtpaket 9 Werkzeuge die Ihnen einen jahrelangen, zuverlässigen Nutzen garantieren.

## Support up to 150kg



### HEAVY-DUTY SUPPORT

Tested up to 150kg, a reliable and durable saddle which doesn't fear large weight.

Getestet bis 150kg, ein zuverlässiger und langlebiger Sattel, der auch größere Belastungen nicht fürchtet.

## E-Bike Specific



### E-FIT DESIGN

An innovative wave-shaped design to help you immediately find the correct position on your e-bike, its elevated rear section will prevent you from sliding backward to ensure maximum comfort for your back, while the uniquely flexible saddle sides add stability and facilitate pedalling.

Ein innovatives, wellenförmiges Design, das Ihnen hilft, sofort die richtige Position auf Ihrem E-Bike zu finden. Der erhöhte hintere Teil verhindert ein Zurückrutschen und sorgt für maximalen Komfort für Ihren Rücken, während die einzigartig flexiblen Sattelseiten für zusätzliche Stabilität sorgen und das Pedalieren erleichtern.

## Easy Handling



### E-GRIP

Get a full hold on your e-bike with this smart feature: an integrated, soft touch handle that makes manoeuvring easy.

Mit diesem cleveren Feature haben Sie Ihr E-Bike voll im Griff: ein integrierter Soft-Touch-Griff, der das Manövrieren erleichtert.

## Sustainable Choice



### ECO APPROACH

Selle Royal is reinforcing its commitment to reduce the environmental impact of its products. The base of this saddle is made using 100% recycled plastic, while maintaining the same level of flexibility and comfortable performance. The BIO-sourced cover consists of 50% organic materials, guaranteeing the same elasticity, abrasion resistance and comfort level whilst using only natural plasticizers.

Selle Royal verstärkt sein Engagement, den ökologischen Fußabdruck seiner Produkte zu reduzieren. Das Sattelgestell dieses Produkts besteht zu 100 % aus recyceltem Kunststoff, wobei das gleiche Maß an Flexibilität und Komfort beibehalten wird. Der Sattelbezug aus BIO-Produktion besteht zu 50 % aus organischen Materialien und gewährleistet die gleiche Elastizität, Abriebfestigkeit sowie den gewohnten Komfort, wobei ausschließlich natürliche Weichmacher verwendet werden.



All Journeys  
Riding Everywhere





**ON Athletic**  
Unisex

-  E-Fit Design
-  Royalgel™
-  E-Grip
-  Royal Vacuum
-  Integrated Clip System



**ON Moderate**  
Unisex

-  E-Fit Design
-  Royalgel™
-  E-Grip
-  Royal Vacuum
-  Integrated Clip System



**ON Relaxed**  
Unisex

-  E-Fit Design
-  Royalgel™
-  E-Grip
-  Royal Vacuum
-  Integrated Clip System



ARTICLE	EAN	NAME	RIDING POSITION	GENDER	SIZES	PRICE (€)
94C7UROA05X37	8021890570239	<b>On</b>	Athletic	Unisex	L 281mm / W 157mm / W 465g	89,90
94C8DROA05X37	8021890570260	<b>On</b>	Moderate	Unisex	L 268mm / W 190mm/ W 531g	89,90
94C9UROA05X37	8021890570291	<b>On</b>	Relaxed	Unisex	L 269mm / W 224mm / W 642g	89,90

**NEW**



**ON OPEN Athletic**  
Unisex

-  Royal Vacuum
-  E-Fit Design
-  E-Grip
-  Royalgel™
-  Ergonomic Hole
-  Integrated Clip System



**NEW**



**ON OPEN Moderate**  
Unisex

-  Royal Vacuum
-  E-Fit Design
-  E-Grip
-  Royalgel™
-  Ergonomic Hole
-  Integrated Clip System



**NEW**



**ON OPEN Relaxed**  
Unisex

-  Royal Vacuum
-  E-Fit Design
-  E-Grip
-  Royalgel™
-  Ergonomic Hole
-  Integrated Clip System



ARTICLE	EAN	NEW	NAME	RIDING POSITION	GENDER	SIZES	PRICE (€)
94F6UROA05X37	8021890592477	<b>NEW</b>	<b>On Open</b>	Athletic	Unisex	L 281mm / W 158mm / W 443g	89,90
94F7DROA05X37	8021890592491	<b>NEW</b>	<b>On Open</b>	Moderate	Unisex	L 269mm / W 190mm / W 499g	89,90
94F8UROA05X37	8021890592514	<b>NEW</b>	<b>On Open</b>	Relaxed	Unisex	L 270mm / W 224mm / W 629g	89,90

### Royalgel™

Superior to any other padding material for its unique formulation, Royalgel™ provides the highest level of comfort. Durable and versatile, this technology absorbs pressure and distributes it across the saddle surface, ensuring the best support for even your longest rides.

Durch seine einzigartige Zusammensetzung übertrifft Royalgel™ jedes andere Polstermaterial und bietet höchsten Komfort: Langlebig und vielseitig, diese Technologie absorbiert den Druck und verteilt ihn über die Satteloberfläche und sorgt für die richtige Unterstützung, auch bei längeren Fahrten.



### Royal Vacuum

Enjoy a dry ride with a water-resistant saddle. This patented Selle Royal technology allows the saddle to be 100% sealed and substantially waterproof, even when exposed to heavy, wet weather.

Diese von Selle Royal patentierte Technologie gewährleistet, dass der Sattel zu 100 % geschlossen und somit wasserdicht ist, selbst wenn er starkem Regen oder extrem nasser Witterung ausgesetzt ist.

### e-Fit Design

An innovative wave-shaped design to help you immediately find the correct position on your e-bike, its elevated rear section will prevent you from sliding backward to ensure maximum comfort for your back, while the uniquely flexible saddle sides add stability and facilitate pedalling.

Ein innovatives, wellenförmiges Design, das Ihnen hilft, sofort die richtige Position auf Ihrem E-Bike zu finden. Der erhöhte hintere Teil verhindert ein Zurückrutschen und sorgt für maximalen Komfort für Ihren Rücken, während die einzigartig flexiblen Sattelseiten für zusätzliche Stabilität sorgen und das Pedalieren erleichtern.



### Integrated Clip System

A must for your Selle Royal accessories: the Integrated Clip System positioned at the rear of your saddle will make the attachment of a Selle Royal saddle bag or other accessories an easy clip away.

Ein Muss für Ihr Selle Royal-Zubehör: Mit dem integrierten Clip-System, das an der Rückseite Ihres Sattels angebracht ist, können Sie eine Selle Royal-Satteltasche oder anderes Zubehör ganz einfach per Clip befestigen.

### Ergonomic Hole

An ergonomic central cut-out designed to relieve pressure in the perineal area, making it ideal for the most sensitive riders. No pain, just gain on your rides!

Eine ergonomische Aussparung in der Mitte, die den Druck im Dammbereich reduziert und somit auch für die empfindlichsten Fahrer geeignet ist. Ohne Schmerzen, dafür mit mehr Spaß auf Ihren Fahrten!



### e-Grip

Get a full hold on your e-bike with this smart feature: an integrated, soft touch handle that makes manoeuvring easy.

Mit diesem cleveren Feature haben Sie Ihr E-Bike voll im Griff: ein integrierter Soft-Touch-Griff, der das Manövrieren erleichtert.



**RESPIRO Athletic**  
Unisex

-  Royalgel™
-  Ventilation Channel
-  Cool Cover
-  Scuff Guards
-  Royal Vacuum
-  Integrated Clip System



**RESPIRO Moderate**  
Unisex

-  Royalgel™
-  Ventilation Channel
-  Cool Cover
-  Scuff Guards
-  Elastomers
-  Royal Vacuum
-  Integrated Clip System



**RESPIRO Relaxed**  
Unisex

-  Royalgel™
-  Ventilation Channel
-  Cool Cover
-  Scuff Guards
-  Elastomers
-  Royal Vacuum
-  Integrated Clip System



ARTICLE	EAN	NAME	RIDING POSITION	GENDER	SIZES	PRICE (€)
5130HRTB691L4	8021890575098	<b>Respiro</b>	Athletic	Unisex	L 279mm / W 159mm / W 429g	79,90
5131HETB291L4	8021890578969	<b>Respiro</b>	Moderate	Unisex	L 277mm / W 182mm / W 535g	79,90
5132DETB291L4	8021890575104	<b>Respiro</b>	Relaxed	Unisex	L 256mm / W 227mm / W 771g	79,90



**LOOKIN Athletic**  
Unisex

-  Royalgel™
-  Cool Cover
-  Scuff Guards
-  Royal Vacuum
-  Integrated Clip System



**LOOKIN Moderate**  
Unisex

-  Royalgel™
-  Cool Cover
-  Scuff Guards
-  Elastomers
-  Royal Vacuum
-  Integrated Clip System



**LOOKIN Relaxed**  
Unisex

-  Royalgel™
-  Cool Cover
-  Scuff Guards
-  Elastomers
-  Royal Vacuum
-  Integrated Clip System



ARTICLE	EAN	NAME	RIDING POSITION	GENDER	SIZES	PRICE (€)
5234HR3A39188	8021890575135	<b>Lookin</b>	Athletic	Unisex	L 279mm / W 160mm / W 440g	69,90
5235DE3A39188	8021890578990	<b>Lookin</b>	Moderate	Unisex	L 269mm / W 198mm / W 620g	69,90
5236DE3A59188	8021890575142	<b>Lookin</b>	Relaxed	Unisex	L 260mm / W 228mm / W 830g	69,90





**LOOKIN Evo Athletic**  
Unisex

- Eco Approach
- Royalgel™
- Flexyte System
- Royal Vacuum
- Integrated Clip System



**LOOKIN Evo Moderate**  
Unisex

- Eco Approach
- Royalgel™
- Flexyte System
- Royal Vacuum
- Integrated Clip System



**LOOKIN Evo Relaxed**  
Unisex

- Eco Approach
- Royalgel™
- Flexyte System
- Cupsprings
- Royal Vacuum
- Integrated Clip System



ARTICLE	EAN	NAME	RIDING POSITION	GENDER	SIZES	PRICE (€)
52E2UROA0B004	8021890579027	<b>Lookin Evo</b>	Athletic	Unisex	L 261mm / W 158mm / W 448g	74,90
52E3HROA0B004	8021890579034	<b>Lookin Evo</b>	Moderate	Unisex	L 271mm / W 186mm / W 500g	74,90
52E4UEOA0B004	8021890579041	<b>Lookin Evo</b>	Relaxed	Unisex	L 248mm / W 223mm / W 682g	74,90

# WE STARTED FROM THE

# BOTTOM



## Lookin Evo

100% recycled plastic base + 50% BIO-sourced cover =  
-24% CO<sub>2</sub> emissions



# Adventure Time

## Exploring Outdoors





**VAIA Athletic**  
Unisex

-  Royalgel™
-  Ergonomic Hole
-  Royal Vacuum
-  Integrated Clip System
-  Multi-Tool



**VAIA Moderate**  
Unisex

-  Royalgel™
-  Ergonomic Hole
-  Royal Vacuum
-  Integrated Clip System
-  Multi-Tool



**VAIA Relaxed**  
Unisex

-  Royalgel™
-  Ergonomic Hole
-  Thermoplastic Damper
-  Royal Vacuum
-  Integrated Clip System



ARTICLE	EAN	NAME	RIDING POSITION	GENDER	SIZES	PRICE (€)
84E5UR0A05X38	8021890593504	<b>Vaia</b>	Athletic	Unisex	L 271mm / W 151mm / W 382g	69,90
84E6HR0A05X38	8021890593511	<b>Vaia</b>	Moderate	Unisex	L 270mm / W 167mm / W 406g	69,90
84E7UE0A05X38	8021890593528	<b>Vaia</b>	Relaxed	Unisex	L 250mm / W 213mm / W 580g	69,90



### Multi-Tool Integrated

This multi-tool attaches to the rear of any Selle Royal saddle thanks to the Integrated Clip System (ICS). This comes already included in the Athletic and Moderate Vaia saddles to always be on hand for quick adjustments and repairs on the road. Protected by an anti-shock rubber housing, this compact and secure package offers 9 tools for years of reliable use.

Dieses Multi-Tool kann dank des Integrated Clip System (ICS) an der Rückseite eines jeden Selle Royal-Sattels befestigt werden. Dies ist bereits Bestandteil der Athletic und Moderate Vaia Sättel, so dass Sie es unterwegs immer zur Hand haben, um schnelle Anpassungen und Reparaturen vorzunehmen. Durch ein stoßfestes Gummigehäuse geschützt, bietet dieses kompakte und sichere Set 9 Werkzeuge für jahrelangen, zuverlässigen Gebrauch.

### Water Resistant

Royal Vacuum Light is a patented Selle Royal technology that allows the saddle to be 100% sealed and therefore water resistant. Also, it makes the saddle 20% lighter!

Die von Selle Royal patentierte Royal Vacuum Light Technologie sorgt dafür, dass der Sattel zu 100% versiegelt und somit wasserdicht ist. Zudem ist der Sattel dadurch 20% leichter!



### Ergonomic Hole

An ergonomic central cut-out designed to relieve pressure in the perineal area, making it ideal for the most sensitive riders. This cutout-saddle ergonomically follows the shape of the body, delivering superior pressure relief in the perineal area and support in the ischiatic zone.

Ein ergonomischer, zentral angeordneter Ausschnitt zur Druckentlastung im Dammbereich macht ihn ideal für besonders feinfühligere Fahrer. Dieser Cutout-Sattel entspricht ergonomisch der Form des Körpers und bietet eine hervorragende Druckentlastung im Dammbereich und Unterstützung in der Ischiaszone.

### Royalgel™

Thanks to its unique tridimensional gel structure, Royalgel™ guarantees the highest level of comfort, reducing pressure peaks by 40% compared to standard padding materials.

Royalgel™ garantiert ein Höchstmaß an Komfort, da es die Spitzenwerte bei der Druckeinwirkung dank der einmaligen dreidimensionalen Gelstruktur um bis zu 40% senkt.

### Thermoplastic Damper (only on Riding Position 90°) (nur bei 90° Fahrposition)

Working like an elastomer, this permanently non-deformable mono damper positioned at the rear of the saddle absorbs even the most severe and unexpected shocks for safe, silent and comfortable performance.

Ähnlich wie ein Elastomer absorbiert dieser nicht verformbare Mono-Dämpfer im hinteren Teil des Sattels selbst die stärksten und unerwartetsten Stöße für ein sicheres, leises und komfortables Fahrverhalten.



### Integrated Clip System

A patented clip system positioned at the rear of the saddle for easy attachment of a Selle Royal saddle bag or other accessory.

Ein patentierte Clip-System an der Rückseite des Sattels zur einfachen Befestigung einer Selle Royal-Satteltasche oder sonstigem Zubehör.



 Selle Royal

Selle Royal



**EXPLORA Athletic**  
Unisex



Royalgel™



Ergonomic Channel



Royal Vacuum



Integrated Clip System



**EXPLORA Moderate**  
Unisex



Royalgel™



Ergonomic Channel



Royal Vacuum



Integrated Clip System



**EXPLORA Relaxed**  
Unisex



Royalgel™



Ergonomic Channel



Thermoplastic Damper



Royal Vacuum



Integrated Clip System



ARTICLE	EAN	NAME	RIDING POSITION	GENDER	SIZES	PRICE (€)
54D1UR0A05X38	8021890569721	<b>Explora</b>	Athletic	Unisex	L 274mm / W 152mm / W 379g	69,90
54D2HR0A05X38	8021890569745	<b>Explora</b>	Moderate	Unisex	L 273mm / W 171mm / W 415g	69,90
54D3UE0A05X38	8021890569769	<b>Explora</b>	Relaxed	Unisex	L 253mm / W 218mm / W 598g	69,90











# Urban Life Moving in the City





**ELLIPSE Athletic**  
Unisex

-  Royalgel™
-  Ergonomic Hole
-  Double-Cover Side Protection
-  Royal Vacuum
-  Integrated Clip System



**ELLIPSE Moderate**  
Unisex

-  Royalgel™
-  Ergonomic Hole
-  Double-Cover Side Protection
-  Elastomers
-  Royal Vacuum
-  Integrated Clip System



**ELLIPSE Relaxed**  
Unisex

-  Royalgel™
-  Ergonomic Hole
-  Double-Cover Side Protection
-  Elastomers
-  Royal Vacuum
-  Integrated Clip System



ARTICLE	EAN	NAME	RIDING POSITION	GENDER	SIZES	PRICE (€)
81B5UR0A09320	8021890593474	<b>Ellipse</b>	Athletic	Unisex	L 265mm / W 163mm / W 406g	54,90
81B6HE0A09321	8021890593481	<b>Ellipse</b>	Moderate	Unisex	L 276mm / W 180mm / W 474g	54,90
81B7UE0A09321	8021890593498	<b>Ellipse</b>	Relaxed	Unisex	L 250mm / W 223mm / W 638g	54,90



### FREEWAY FIT Athletic Unisex



Slow Fit  
Foam



Royal  
Vacuum



Integrated  
Clip System



### FREEWAY FIT Moderate Unisex



Slow Fit  
Foam



Scuff  
Guards



Royal  
Vacuum



Integrated  
Clip System



### FREEWAY FIT Relaxed Unisex



Slow Fit  
Foam



Scuff  
Guards



Royal  
Vacuum



Integrated  
Clip System



ARTICLE	EAN	NAME	RIDING POSITION	GENDER	SIZES	PRICE (€)
8V99UROA38069	8021890575623	<b>Freeway Fit</b>	Athletic	Unisex	L 280mm / W 158mm / W 435g	44,90
8V97DROA38069	8021890578891	<b>Freeway Fit</b>	Moderate	Unisex	L 260mm / W 188mm / W 520g	44,90
8V98UROA38069	8021890575616	<b>Freeway Fit</b>	Relaxed	Unisex	L 257mm / W 210mm / W 550g	44,90



**FLOAT Athletic Unisex**

-  Slow Fit Foam
-  Ergonomic Hole
-  Royal Vacuum
-  Integrated Clip System



**FLOAT Moderate Unisex**

-  Slow Fit Foam
-  Ergonomic Hole
-  Elastomers
-  Royal Vacuum
-  Integrated Clip System



**FLOAT Relaxed Unisex**

-  Slow Fit Foam
-  Ergonomic Hole
-  Elastomers
-  Royal Vacuum
-  Integrated Clip System



ARTICLE	EAN	NAME	RIDING POSITION	GENDER	SIZES	PRICE (€)
8VC1UR0A38V14	8021890575593	<b>Float</b>	Athletic	Unisex	L 267mm / W 161mm / W 382g	44,90
8VC2DE0A38V14	8021890579003	<b>Float</b>	Moderate	Unisex	L 263mm / W 200mm / W 547g	44,90
8VC3UE0A38V14	8021890575609	<b>Float</b>	Relaxed	Unisex	L 251mm / W 228mm / W 628g	44,90



**AVENUE Athletic**  
Unisex



**AVENUE Moderate**  
Unisex



**AVENUE Relaxed**  
Unisex



ARTICLE	EAN	NAME	RIDING POSITION	GENDER	SIZES	PRICE (€)
8468HGOA28096	8021890575661	<b>Avenue</b>	Athletic	Unisex	L 265mm / W 158mm / W 462g	39,90
8466DGOA28096	8021890578907	<b>Avenue</b>	Moderate	Unisex	L 258mm / W 183mm / W 664g	39,90
8493DGOA28096	8021890575678	<b>Avenue</b>	Relaxed	Unisex	L 267mm / W 218mm / W 730g	39,90



**VIVO Athletic**  
Unisex



Foam Matrix



Reflective Film



Ergonomic Channel



**DRIFTER STRENGTEX**  
Relaxed / Unisex



Royalgel™



Strengetex



Double Springs



Royal Vacuum



**DRIFTER PLUS Relaxed**  
Unisex



Royalgel™



Double Springs



Royal Vacuum



ARTICLE	EAN	NAME	RIDING POSITION	GENDER	SIZES	PRICE (€)
1217DRNA37823	6957312803093	<b>Vivo</b>	Athletic	Unisex	L 249mm / W 160mm / 375g	29,90
5111UDTC95301	8021890575371	<b>Drifter Strengetex</b>	Relaxed	Unisex	L 270mm / W 245mm / W 1160g	54,90
5111UDTD08129	8021890575388	<b>Drifter Plus</b>	Relaxed	Unisex	L 270mm / W 245mm / W 1173g	54,90



**ONDINA Relaxed Unisex**



Royalgel™



Springs



Royal Vacuum



Integrated Clip System



**HOLLAND Relaxed Unisex**



Royalgel™



Springs



Royal Vacuum



Integrated Clip System



**WITCH Relaxed Unisex**



Foam Matrix



Springs



Royal Vacuum



ARTICLE	EAN	NAME	RIDING POSITION	GENDER	SIZES	PRICE (€)
8171US0A98129	8021890575630	<b>Ondina</b>	Relaxed	Unisex	L 253mm / W 214mm / W 690g	34,90
82615G2A18132	8021890575654	<b>Holland</b>	Relaxed	Unisex	L 247mm / W 219mm / W 690g	29,90
8013USTA18096	8021890581570	<b>Witch</b>	Relaxed	Unisex	L 260mm / W 243mm / W 651g	19,90





Kids saddles



# Kids Saddles

## FROGGY

Suggested for 12"-14"-16" kids bike  
 Passend für 12", 14" oder 16" Kinderräder



## CANDY

Suggested for 16"-20"-24" kids bike  
 Passend für 16", 20" oder 24" Kinderräder



## BEN

Suggested for 16"-20"-24" kids bike  
 Passend für 16", 20" oder 24" Kinderräder

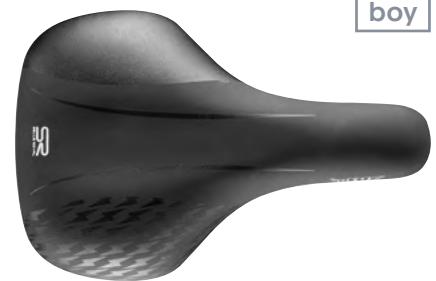

## HELLO

Suggested for 24" junior bike  
 Ein Sitz für 24" Kinderräder

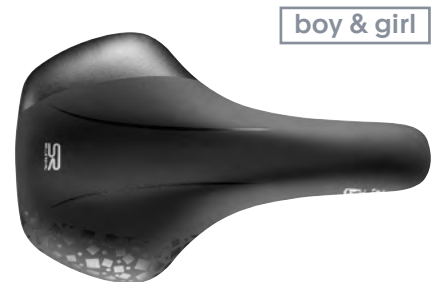

ARTICLE	EAN	NAME	RIDING POSITION	GENDER	SIZES	PRICE (€)
1702JCNA03807	6957312801310	<b>Froggy</b>	Kids 12"-16"	Boy & Girl	L 202mm / W 150mm / W 287g	19,90
1703DRNA03807	6957312801327	<b>Candy</b>	Kids 16"-24"	Girl	L 230mm / W 172mm / W 320g	19,90
1703HRNA03807	6957312801334	<b>Ben</b>	Kids 16"-24"	Boy	L 230mm / W 151mm / W 290g	19,90
1704JRNA03807	6957312801341	<b>Hello</b>	Junior 24"	Boy & Girl	L 250mm / W 151mm / W 325g	19,90

# Saddle bags

## Saddle Bag Medium - 1,2L

Integrated clip system compatible,  
allen key included, external light clip.

Kompatibel mit dem integrierten Clip-System,  
Inklusive Inbusschlüssel, externer Lichtclip.



## Saddle Bag Large - 2,0L

Integrated Clip System compatible,  
allen key included, waterproof,  
external light clip.

Kompatibel mit dem integrierten Clip-System,  
Inklusive Inbusschlüssel, wasserdicht,  
externer Lichtclip.



## Saddle Bag Extra Large - 7,0L

Integrated Clip System compatible,  
allen key included, waterproof,  
external light clip, shoulder strap included.

Kompatibel mit dem integrierten Clip-System,  
Inklusive Inbusschlüssel, wasserdicht,  
externer Lichtclip, inklusive Schultergurt.



ARTICLE	EAN	NAME	COVER	SIZES	PRICE (€)
BAGS300A00000	8021890494955	<b>Saddle Bag Medium 1,2L</b>	Polyester, PVC	L 210mm / W 95mm / H 115mm	19,90
BAGS400A00000	8021890494979	<b>Saddle Bag Large 2,0L</b>	Water resistant Polyester, PVC	L 330mm / W 190mm / H 95mm	24,90
BAGS500A00000	8021890574916	<b>Saddle Bag Extra Large 7,0L</b>	Water resistant Polyester, PVC	L 618mm / W 236mm / H 175mm	59,90

## Seat Covers

### Royalgel™ Seat Cover Small & Large - Unisex

Anatomical indent  
Visibile Royalgel™  
Anatomische Vertiefung  
Sichtbares Royalgel™



### Slow Fit Foam Seat Cover Small & Large - Unisex

Anatomical indent  
Slow Fit Foam  
Anatomische Einbuchtung  
Slow Fit Foam



ARTICLE	EAN	NAME	COLOR	SIZES	PRICE (€)
SCVM300A05800	6957312803116	<b>Royalgel™ Seat Cover Small</b>	Black/Orange	L 270mm / W 190mm / W 244g	19,90
SCVL300A05800	6957312803147	<b>Royalgel™ Seat Cover Large</b>	Black/Orange	L 248mm / W 221mm / W 254g	19,90
SCMM100A75800	6957312803109	<b>Slow Fit Foam Seat Cover Small</b>	Black	L 273mm / W 185mm / W 160g	19,90
SCML100A75800	6957312803130	<b>Slow Fit Foam Seat Cover Large</b>	Black	L 251mm / W 220mm / W 168g	19,90

# Accessories

**Packable Rain Cover  
Dispenser**



**Clamp  
Black / Silver**



ARTICLE	EAN	NAME	COLOR	SIZES/QUANTITY	PRICE (€)
SRSC000A00000	8021890574077	<b>Packable rain cover dispenser</b>	Black	L 107mm / W 120mm / H 258mm	11,90
V006000C00000	8021890472533	<b>Clamp</b>	Black	3 Components (single packaging)	3,00
V006000B90000	8021890472526	<b>Clamp</b>	Silver	3 Components (single packaging)	2,50
V006000C10000	8021890472540	<b>Clamp</b>	Silver	5 Components 38 D. (single packaging)	2,50
V006000B70000	8021890324665	<b>Clamp</b>	Black	3 Components + Locknut	2,00
V006000B60000	8021890324658	<b>Clamp</b>	Silver	3 Components + Locknut	2,00
V006000B80000	8021890324672	<b>Clamp</b>	Silver	5 Components 38 D.	2,00

## Spare parts

The Original Spare Parts by Selle Royal are saddles used for spare parts and are supplied in dedicated masterboxes. They are provided with a special descriptive hangtag.

Die Original Spare Parts by Selle Royal sind Austausch Sättel für spezielle Bedürfnisse unserer Kunden. Jeder Sattel wird in einer eigens für ihn gefertigten Box, mitsamt speziellem Hangtag geliefert.



**Mach Box Athletic**  
Unisex / 28 pcs



**Lancia Box Athletic**  
Unisex / 20 pcs



**Avenue Box Athletic**  
Unisex / 24 pcs



**Moody Box Moderate**  
Woman / 18 pcs



**Rio Unitech Moderate**  
Unisex / 15 pcs



**Holland Unitech Relaxed**  
Unisex / 10 pcs



ARTICLE	EAN	NAME	RIDING POSITION	GENDER	QUANTITY/BOX
SRTC000C70000	8021890459428	<b>Mach Box</b>	Athletic	Unisex	28 pcs
SRTC000C80000	8021890459435	<b>Lancia Box</b>	Athletic	Unisex	20 pcs
SRTC000C90000	8021890459442	<b>Avenue Box</b>	Athletic	Unisex	24 pcs
8072DROA18067	8021890443656	<b>Moody Box</b>	Moderate	Woman	18 pcs
302ODRMA12010	8021890498564	<b>Rio Unitech</b>	Moderate	Unisex	15 pcs
3061USOA12010	8021890485816	<b>Holland Unitech</b>	Relaxed	Unisex	10 pcs

# SELLE ROYAL SCIENTIA FOR CYCLISTS

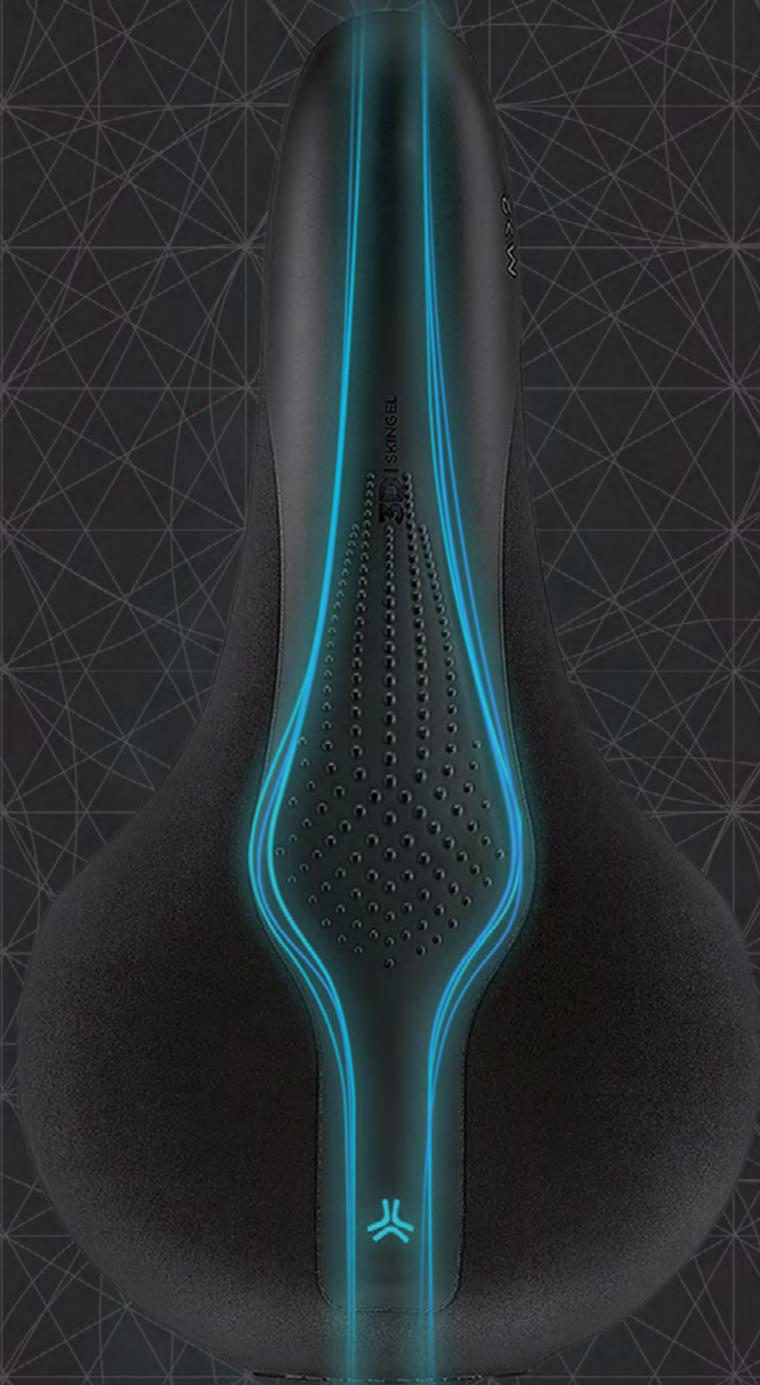

Scientifically developed in collaboration with



Deutsche  
Sporthochschule Köln  
German Sport University Cologne

Product range



ARTICLE	EAN	NAME	RIDING POSITION	ISCHIAL VARIATION	GENDER	SIZES	PRICE (€)
54AOSBOA09210	8021890427045	<b>Scientia A1</b>	Athletic	Small	Unisex	L 289mm / W 127mm / W 380g	89,90
54AOMBOA09210	8021890427038	<b>Scientia A2</b>	Athletic	Medium	Unisex	L 289mm / W 144mm / W 390g	89,90
54AOLBOA09210	8021890427021	<b>Scientia A3</b>	Athletic	Large	Unisex	L 289mm / W 159mm / W 415g	89,90
54MOSBOA09210	8021890427076	<b>Scientia M1</b>	Moderate	Small	Unisex	L 289mm / W 141mm / W 425g	89,90
54MOMBOA09210	8021890427069	<b>Scientia M2</b>	Moderate	Medium	Unisex	L 289mm / W 161mm / W 455g	89,90
54MOLBOA09210	8021890427052	<b>Scientia M3</b>	Moderate	Large	Unisex	L 289mm / W 178mm / W 465g	89,90
54ROSBOA09210	8021890427106	<b>Scientia R1</b>	Relaxed	Small	Unisex	L 289mm / W 169mm / W 479g	89,90
54ROMBOA09210	8021890427090	<b>Scientia R2</b>	Relaxed	Medium	Unisex	L 289mm / W 196mm / W 485g	89,90
54ROLBOA09210	8021890427083	<b>Scientia R3</b>	Relaxed	Large	Unisex	L 289mm / W 224mm / W 520g	89,90



# Scientia features



## Body contour

A radius-specific design to provide optimum comfort for differing spine angles. The more inclined the Riding Position, the smaller the edge-radius.

Ein Radius-spezifisches Design, das unterschiedlichen Wirbelsäulenwinkeln optimalen Komfort bietet. Je gestreckter die Sitzposition, desto geringer der Radius der Flanke.



## Rear plateau

An elevated rear section to prevent backward sliding and decrease pressure in the saddle middle which can cause discomfort.

Ein erhöhter Heckbereich, der vor Verrutschen nach hinten schützt und den Druck in der Mitte des Sattels, dem Auflageort des Dammbereichs, verringert, um Beschwerden vorzubeugen.



## Central reservoir

Indentation in the saddle middle whose shape and dimensions have been studied to correspond to ischial variations for greater comfort.

Eine Vertiefung in der Sattelmittle, deren Form und Größe mit den Sitzknochenabständen korrespondieren - für größeren Komfort.

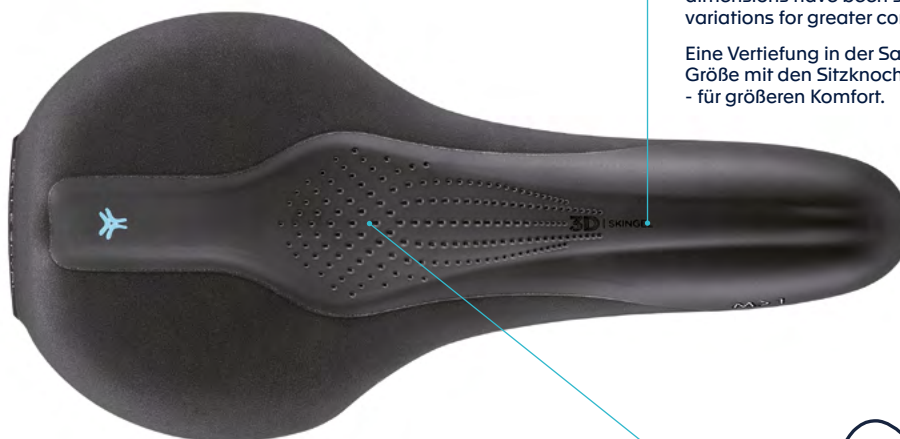

## 3D Skingel

Royalgel™ is placed intelligently at critical points of contact on the saddle surface for added shock absorption, while reducing overall saddle weight.

Royalgel™ wurde an den kritischen Kontaktpunkten der Satteloberfläche verbaut, für eine erhöhte Dämpfung bei gleichzeitiger Gewichtsreduzierung des Sattels.



## Curva suspension

The unique curved suspension design is attached at the rear of the base to offer exclusive comfort by avoiding pressure on the seat bone contact points and guaranteeing additional lateral flexibility.

Die einteilige gebogene Sattelstrebe dämpft insbesondere den Bereich der Sitzknochen und bietet daher ein spürbares Mehr an Komfort.



# Measurement steps

## 1 Find your riding position Bestimmen Sie Ihre Sitzposition

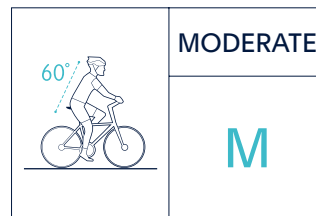

## 2 Determine your ischial variation Ermitteln Sie Ihren Sitzknochenabstand

Reset the gel pad.

Glätten Sie das Gelkissen.

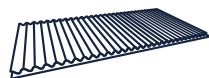

Sit at 90° and apply pressure.

Setzen Sie sich mit senkrechtem Rücken darauf und belasten Sie die Sitzfläche.



Find the centres of the two ischial impressions and add together the two numbers. The result is your ischial distance.

Finden Sie den jeweiligen Mittelpunkt der beiden Sitzknochenabdrücke und addieren Sie die beiden Zahlen. Die Summe daraus ist ihr Sitzknochenabstand.

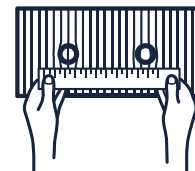

Example/Beispiel:  
5cm + 7cm = 12cm





“Supporting Cyclists” has always been the Selle Royal mission: for more than 60 years, we have offered cyclists the best ride possible through affordable, high-quality saddles and accessories. But for us that’s not enough, so we came up with a new way to make your riding experience even more enjoyable.

### **Have a coffee while we check your bike!**

The Selle Royal Van is travelling around Europe to meet cyclists and hear their stories, offering free coffee, a bike checkup and a warm smile from our Van team. All cyclists are invited to be part of this experience, no matter what you ride.

Simply join us by following the Van adventures and you’ll know where to find us next.

“Supporting Cyclists” war schon immer Selle Royal’s Mission: Seit über 60 Jahren bieten wir Radfahrern die bestmögliche Fahrt durch erschwingliche, hochwertige Sättel und Fahrradzubehör. Für uns ist das aber noch nicht genug - daher haben wir uns etwas Neues ausgedacht, um dein Fahrerlebnis noch angenehmer zu gestalten.

### **Have a coffee while we check your bike!**

Der Selle Royal Van reist quer durch Europa, um Fahrradfahrer zu treffen und ihren Geschichten zu lauschen - vom Van Team gibt es kostenlos Kaffee, Fahrrad-Checkups und ein herzliches Lächeln. Alle Radfahrer sind eingeladen bei der Aktion dabei zu sein, ganz egal, was du fährst.

Schließe dich uns einfach an, indem du den Van Abenteuern folgst und immer über unseren nächsten Stop informiert bist.



Selle Royal

Have a coffee  
while we check  
your bike!

Selle Royal

follow the van adventures on  
[www.selleroyal.com](http://www.selleroyal.com)



ZB  
990 AE



RECOVERY zone  
with memory foam

SUPPORT zone

r.e.med

ACTIVE zone

RECOVERY zone  
with memory foam

SUPPORT zone

r.e.med

ACT

0 1 2 3

r.e.med

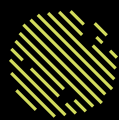

r.e.med

# The ergonomic approach

**R.e.Med** saddles are designed to allow the body to naturally redistribute stress by offering 3 corresponding Saddle Zones: **ACTIVE**, **RECOVERY** and **SUPPORT** to correlate to the 3 riding positions, providing relief and comfort by equalizing pressure as you shift position between the front and rear of the saddle.

**R.e.Med** Sättel wurden design't um es dem Körper zu ermöglichen, die auftretende Belastung natürlich auf 3 Sattelzonen zu verteilen: **AKTIV**, **ERHOLUNG** und **UNTERSTÜTZUNG**, diese bieten Entlastung und Komfort, das Polster behält dabei unverändert seinen Druck, auch wenn Sie die Sitzposition von vorne nach hinten verlagern.

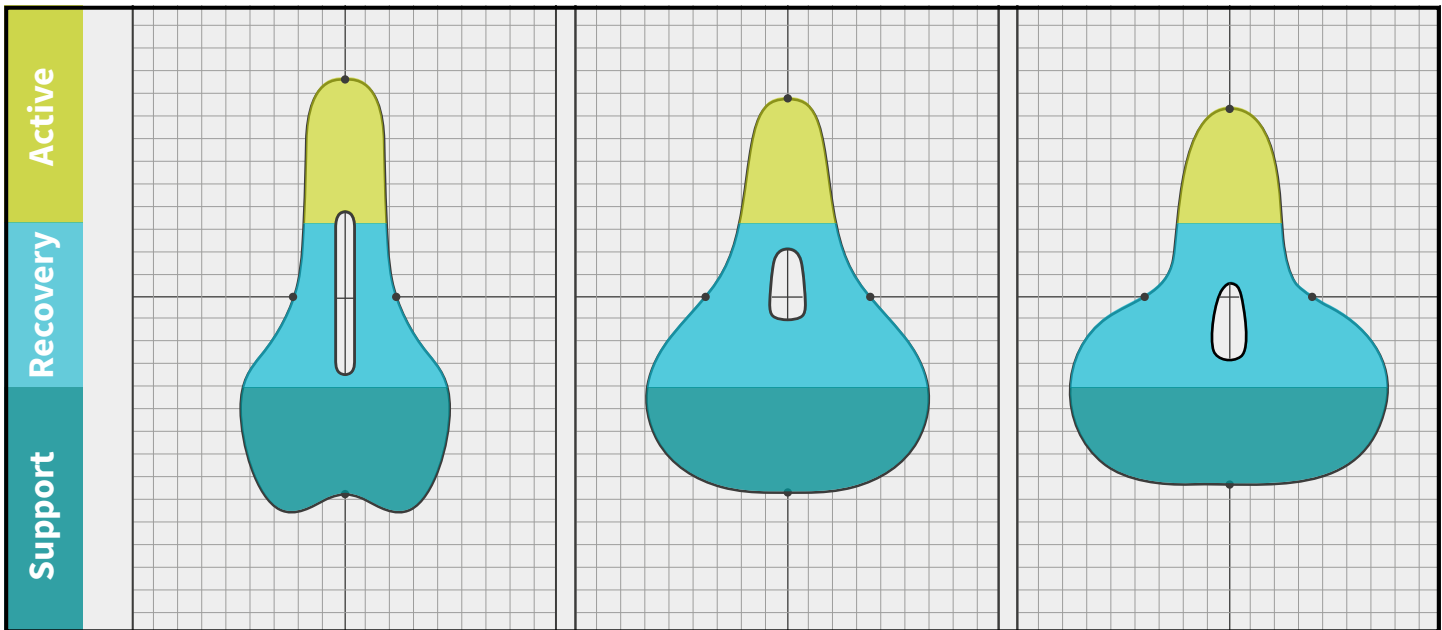

## The features

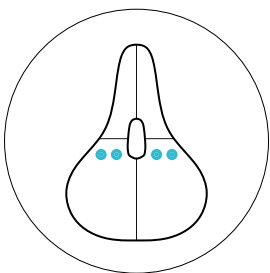

Specific Ergonomic Design

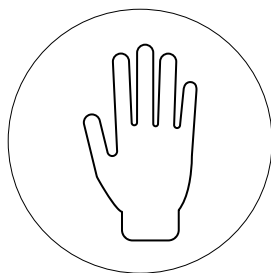

Handmade

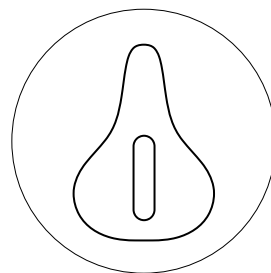

Anatomic Hole

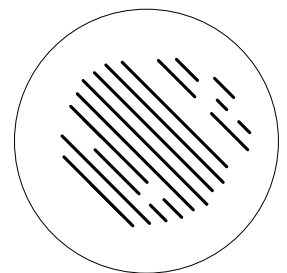

Memory Foam

# Product range



ARTICLE	EAN	NAME	RIDING POSITION	GENDER	SIZES	PRICE (€)
2354HRMA10004	6957312801471	<b>Remed Sport</b>	Sport	Unisex	L 287mm / W 136mm / W 316g	26,90
4309DEMA10004	6957312801488	<b>Remed Trekking</b>	Trekking	Unisex	L 257mm / W 189mm / W 578g	26,90
5550UEMA10003	6957312801495	<b>Remed City</b>	City	Unisex	L 249mm / W 207mm / W 633g	26,90



fi'zi:k







**fizik's** mission is to make the most beautiful, inspiring and sophisticated gear for the world's most discerning cyclists.

**fizik** hat es sich zur Aufgabe gemacht, die schönste, inspirierendste und anspruchsvollste Ausrüstung für die anspruchsvollsten Radfahrer der Welt herzustellen.

*/fi'zi:k/*

Phonetic spelling of the word physique, referring to the form or state of the human body.

Die phonetische Schreibweise des Wortes Körperbau, die sich auf die Form oder den Zustand des menschlichen Körpers bezieht.

Behind fizik's diverse product range, the passion for design and performance in off-road riding, road cycling and triathlon is expressed through countless victories in the pro ranks along and numerous design awards, making fizik the choice of Sport's most inspiring athletes.

Whether bar tape, components, footwear or saddles, fizik is committed to providing the ultimate in design—combining comfort and lightweight construction with technology and innovation.

Through anatomical studies, physiological research, and advanced technological development, fizik has achieved the perfect combination.

Whether you challenge yourself or other riders, pro or amateur, if you're searching for the most beautiful, best performing cycling gear, fizik is the answer.

Hinter der vielfältigen Produktpalette von fizik steht die Leidenschaft für Design und Leistung im Gelände-, Straßenrad und Triathlonsport. Unzählige Siege in den Pro-Rängen und zahlreiche Designpreise machen fizik zur Wahl der ambitioniertesten und inspirierendsten Athleten des Sports.

Ob Lenkerband, Komponenten, Schuhe oder Sättel, fizik hat sich zum Ziel gesetzt, das Nonplusultra in Design, Komfort und Leichtbau mit modernster Technologie und Innovation zu verbinden.

Dank anatomischer Studien, physiologischer Forschung und fortschrittlicher technologischer Entwicklung ist fizik die perfekte Kombination gelungen.

Ob Sie sich selbst oder andere Fahrer herausfordern, ob Profi oder Amateur, wenn Sie auf der Suche nach der schönsten und leistungsfähigsten Radsportausrüstung sind, ist fizik die Antwort.

# **SERIES**

Fizik designs products for and engages in conversations with any cyclist in search of **beauty** and **performance**.

There are many kinds of cyclists, each with different desires, attitudes and needs.

We have organized both our product range and our communication around these needs.

Fizik entwirft Produkte für und führt Gespräche mit Radfahrern, die nach **Schönheit** und **Leistung streben**.

Es gibt verschiedene Arten von Radfahrern, alle mit unterschiedlichen Wünschen, Einstellungen und Bedürfnissen.

Wir haben sowohl unser Produktsortiment als auch unsere Kommunikation rund um diese Bedürfnisse organisiert.

# SERIES



## VENTO

RACING series designed in collaboration with professional cyclists.

RACING Eine in Zusammenarbeit mit Profi-Radsportlern entwickelte Linie.

DISCIPLINES/DISZIPLINEN:  
Road Cycling, XC, CX



## TEMPO

ROAD series designed to provide the most enjoyable and versatile riding experience.

ROAD Diese Linie wurde entwickelt, um das angenehmste und vielseitigste Fahrerlebnis zu bieten.

DISCIPLINES/DISZIPLINEN:  
Road Riding, Randonnée



## TERRA

ALL-TERRAIN series designed to take you beyond your boundaries.

ALL-TERRAIN Diese Linie wurde entwickelt, um Ihre Grenzen zu überschreiten.

DISCIPLINES/DISZIPLINEN:  
Gravel, All-Mountain, eMTB



## GRAVITA

GRAVITY series designed to take you down the mountain fast and in control.

GRAVITY Die Linie für diejenigen, die schnell und kontrolliert den Berg hinunterfahren wollen.

DISCIPLINES/DISZIPLINEN:  
Enduro, Downhill



## TRANSIRO

TRIATHLON series designed for uncompromised cycling performance and efficient transitions.

TRIATHLON Eine Linie speziell entwickelt für kompromisslose Radsportleistung und effiziente Übergänge.

DISCIPLINES/DISZIPLINEN:  
Triathlon, Ironman



# SADDLES



# SHAPES

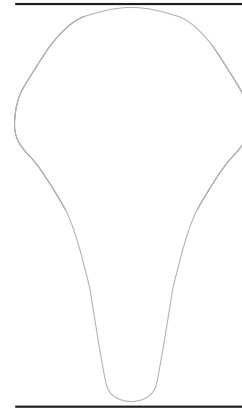

## SHORT NOSE

A short-nosed saddle puts the rider in a more planted position, making for greater stability, better weight distribution and a more generous ischial support compared to a traditional saddle. The short length saddle allows the rider to sit further forward without placing undue pressure on sensitive tissues.

Verglichen mit einem traditionellen Sattel, bringt ein Sattel mit kurzem Nasenteil den Fahrer in eine stabilere Sitzhaltung, die eine bessere Gewichtsverteilung und eine großzügigere Unterstützung der Sitzknochen ermöglicht. Der kurze Sattel ermöglicht es dem Fahrer, weiter vorne zu sitzen, ohne übermäßigen Druck auf empfindliche Gewebe auszuüben.

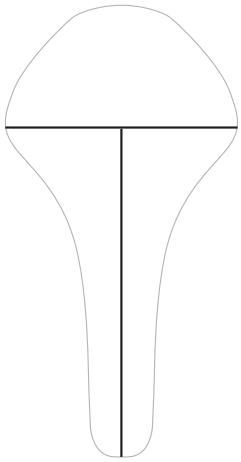

## T-SHAPE

A high-performance saddle with a streamlined shape and tapered nose- to-wing transition. Designed to allow a responsive feeling in every racing condition.

Ein High Performance Sattel mit einer stromlinienförmigen Form und einem konischen Übergang von der Nase zu den Flanken. Entwickelt, um ein feinfühliges Gefühl in jeder Rennsituation zu vermitteln.

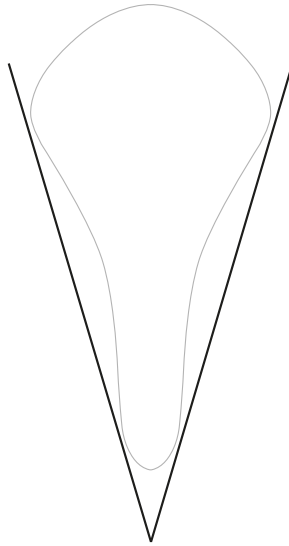

## V-SHAPE

Saddle that features a gradual, tapered transition from wing to nose. With a slightly wider platform to support the ischial bones.

Ein Sattel mit einem fließenden, sich verjüngenden Übergang von den Flanken zur Nase. Mit einer etwas breiteren Auflagefläche zur Unterstützung der Sitzknochen.

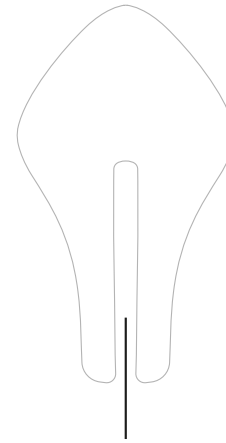

## SPLIT NOSE

Saddle engineered with a divided nose. Two independent halves allow for an unprecedented pressure-relief system while continuing to maintain the firm support and balance needed for long hours spent in the aero position.

Dieser Sattel wurde mit einer zweigeteilten Nase entwickelt. Zwei unabhängige Hälften ermöglichen ein einzigartiges System zur Druckentlastung, während sie gleichzeitig den nötigen festen Halt und die Ausgewogenheit für lange Stunden in der Aero-Position bieten.

# SURFACES

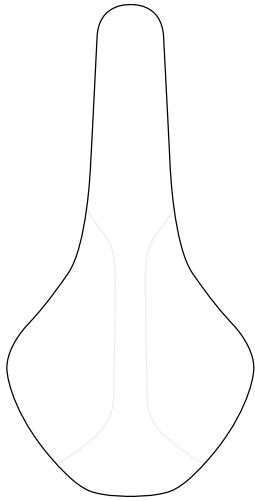

## SOLID

Handmade construction for optimal power transfer, combined with a resilient cushioning for even distribution of body weight.

Handgefertigte Ausführung für optimale Kraftübertragung, kombiniert mit einer elastischen Dämpfung zur gleichmäßigen Verteilung des Körpergewichts.

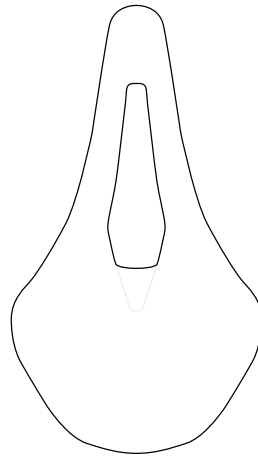

## CUT-OUT

An ergonomic cut-out developed through detailed pressure analysis and input from medical experts to relieve pressure on the soft tissue areas. Found on all Argo as well as Arione, Antares and Aliante Open saddles.

Ein ergonomischer Ausschnitt, der auf der Grundlage einer detaillierten Druckanalyse und des Inputs medizinischer Experten entwickelt wurde und den Druck auf den Weichteilgewebereich mindert. Bei allen Argo-Sätteln sowie bei den Arione, Antares und Aliante Open-Sätteln zu finden.

# RAILS

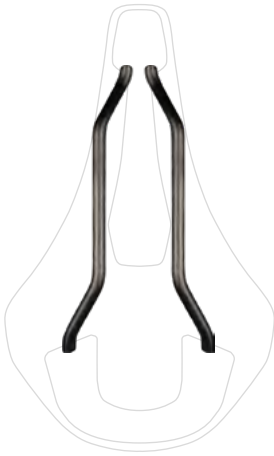

## CARBON

Rather than a conventional solid or tubular rail, fizik's rails use an outer sleeve of braided carbon fibers forming a tube, with the void inside being filled by unidirectional carbon fibers. This construction is strong, light and stiff.

Anstelle herkömmlicher vollwandiger oder röhrenförmiger Sattelstreben verwendet Fizik-Streben mit einer äußeren Ummantelung aus geflochtenen Kohlefasern, die eine Röhre bilden, wobei der Hohlraum im Inneren mit unidirektionalen Kohlefasern gefüllt wird. Diese Konstruktion ist stabil, leicht und steif.

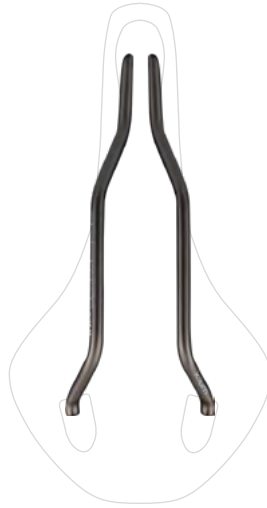

## KIUM

Kium is a combination of a particular metal alloy, a specific tubular design and a special finishing process which increases fatigue performance on the rail surface. This delivers 8% weight reduction compared to solid titanium providing a high strength-to weight ratio grade and high corrosion resistance.

Kium ist eine Kombination aus einer bestimmten Metalllegierung, einer speziellen Rohrkonstruktion und einem speziellen Fertigungsverfahren, das die Ermüdungsbeständigkeit an der Schienenoberfläche erhöht. Dies führt zu einer Gewichtsreduzierung von 8 % im Vergleich zu massivem Titan und bietet einen hohen Festigkeits-Gewichts-Verhältnisgrad und eine hohe Korrosionsbeständigkeit.

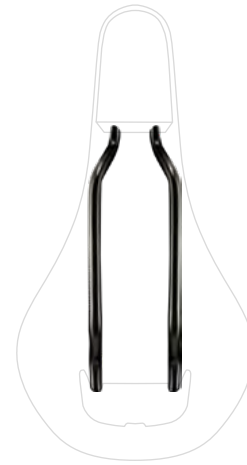

## S-ALLOY

This specific metal alloy is a proprietary blend of iron, carbon (0.2%) and other minerals, like chrome and molybdenum. The low content of carbon combined with a specific finishing treatment, results in a strong and high corrosion resistant rail system.

Diese spezielle Metalllegierung ist eine proprietäre Mischung aus Eisen, Kohlenstoff (0.2%) und anderen Mineralien, wie Chrom und Molybdän. Der niedrige Kohlenstoffgehalt in Verbindung mit einer speziellen Endbehandlung führt zu stabilen und hoch korrosionsbeständigen Sattelstreben.

# ROAD AND TRIATHLON SADDLES

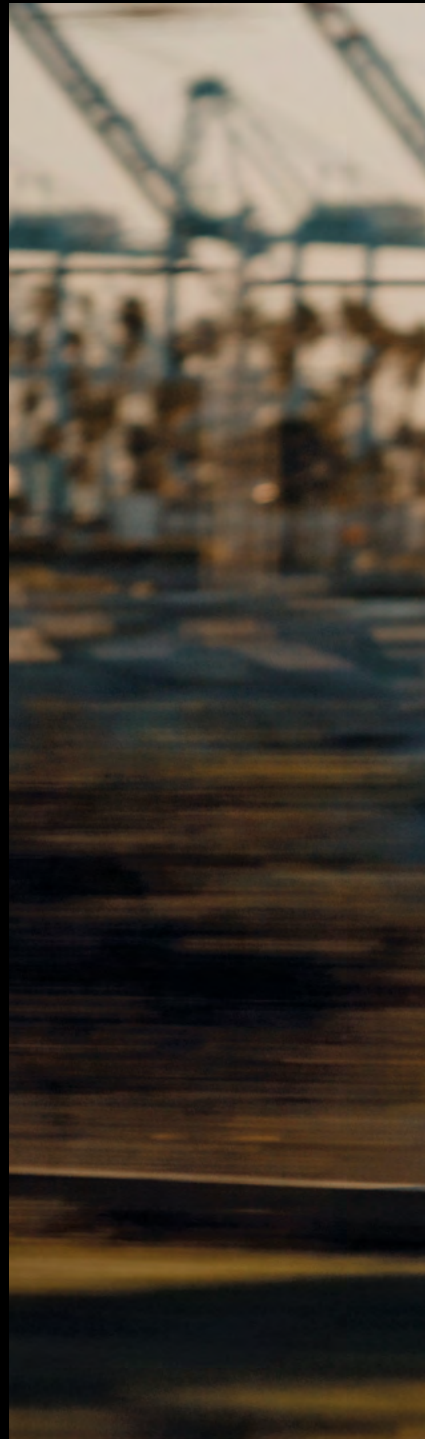





## VENTO ARGO ADAPTIVE

A short nosed, performance saddle featuring the revolutionary, 3D-printed Adaptive padding for seamlessly engineered zonal cushioning, improved comfort and greater stability.

Ein kurznasiger Performance-Sattel mit der revolutionären, im 3D-Druck hergestellten adaptiven Polsterung für nahtlos konstruierte Zonenpolsterung, verbesserten Komfort und größere Stabilität.



**VENTO**  
**ARGO 00**  
**ADAPTIVE**

Intended use: ROAD RACING

**Regular**  
L 265mm | W 140mm | W 175g  
**Large**  
L 265mm | W 150mm | W 186g



**VENTO**  
**ARGO R1**  
**ADAPTIVE**

Intended use: ROAD RACING, XC, CX

**Regular**  
L 265mm | W 140mm | W 190g  
**Large**  
L 265mm | W 150mm | W 196g



**VENTO**  
**ARGO R3**  
**ADAPTIVE**

Intended use: ROAD RACING, XC, CX

**Regular**  
L 265mm | W 140mm | W 224g  
**Large**  
L 265mm | W 150mm | W 230g



ARTICLE	EAN	MODEL	SIZE	COLOR	RAILS	SHELL	PADDING	SRP (€)
77F1D00A0P003	8021890583536	<b>Vento Argo 00 Adaptive</b>	<b>140mm</b>	Black	Carbon Mobius 7x9mm	Full Carbon	Adapitve padding	399
77F2D00A0P003	8021890583543		<b>150mm</b>					399
70F1D00A0P002	8021890571090	<b>Vento Argo R1 Adaptive</b>	<b>140mm</b>	Black	Carbon 7x9mm	Carbon Reinforced Nylon with WingFlex	Adapitve padding	299
70F2D00A0P002	8021890571113		<b>150mm</b>					299
70F1D00A1P002	8021890571106	<b>Vento Argo R3 Adaptive</b>	<b>140mm</b>	Black	Kium 7x7mm	Carbon Reinforced Nylon with WingFlex	Adapitve padding	259
70F2D00A1P002	8021890571120		<b>150mm</b>					259

## VENTO ARGO

Vento Argo has been engineered to deliver a riding feel that suits race bikes with aggressive geometry. The purposeful shape of its design helps you achieve a better riding posture: the dropped nose supports the pubic ramus when the pelvis rotates forward to add power or to get more aero.

Der Vento Argo wurde entwickelt, um ein Fahrgefühl zu vermitteln, das zu Rennmaschinen mit aggressiver Geometrie passt. Die zweckmäßige Form seines Designs hilft Ihnen dabei, eine bessere Fahrhaltung zu erreichen: Die abfallende Nase unterstützt das Schambein, wenn sich das Becken nach vorne dreht, um mehr Kraft zu erzeugen oder um mehr in die Aero-Position zu kommen.



**VENTO**  
**ARGO 00**

Intended use: ROAD RACING

**Regular**

L 265mm | W 140mm | W 134g

**Large**

L 265mm | W 150mm | W 139g



**VENTO**  
**ARGO R1**

Intended use: ROAD RACING

**Regular**

L 265mm | W 140mm | W 179g

**Large**

L 265mm | W 150mm | W 186g



**VENTO**  
**ARGO R3**

Intended use: ROAD RACING

**Regular**

L 265mm | W 140mm | W 213g

**Large**

L 265mm | W 150mm | W 220g



**VENTO**  
**ARGO R5**

Intended use: ROAD RACING

**Regular**

L 265mm | W 140mm | W 225g

**Large**

L 265mm | W 150mm | W 232g



ARTICLE	EAN	MODEL	SIZE	COLOR	RAILS	SHELL	PADDING	SRP (€)
77D7Y00A0E000	8021890499271	<b>Vento Argo 00</b>	<b>140mm</b>	Black	Carbon Mobius 7x9mm	Full Carbon	EVA padding	299
77D8Y00A0E000	8021890499288		<b>150mm</b>					299
70D7S00A03A23	8021890486486	<b>Vento Argo R1</b>	<b>140mm</b>	Black	Carbon 7x9mm	Carbon Reinforced Nylon with WingFlex	Type 1	199
70D8S00A03A23	8021890486516		<b>150mm</b>					199
70D7S00A13A22	8021890486493	<b>Vento Argo R3</b>	<b>140mm</b>	Black	Kium 7x7mm	Carbon Reinforced Nylon with WingFlex	Type 1	149
70D8S00A13A22	8021890486523		<b>150mm</b>					149
70D7S00A23A22	8021890486509	<b>Vento Argo R5</b>	<b>140mm</b>	Black	S-Alloy 7x7mm	Carbon Reinforced Nylon with WingFlex	Type 1	109
70D8S00A23A22	8021890486530		<b>150mm</b>					109

## TEMPO ARGO

As the endurance riding option, Tempo Argo has been engineered to deliver a riding feel that suits the balanced geometry of today's all-purpose road machines. The padding is slightly thicker around the ischial sit bones area to support a more upright riding posture, providing more long-distance comfort.

Als Option für den Langstreckeneinsatz wurde der Tempo Argo so konstruiert, dass er ein Fahrgefühl vermittelt, das der ausgewogenen Geometrie der heutigen Allzweck-Straßenmaschinen entspricht. Die Polsterung ist im Bereich der Sitzbeinhöcker etwas dicker, um eine aufrechtere Sitzhaltung zu unterstützen und mehr Komfort auf langen Strecken zu bieten.

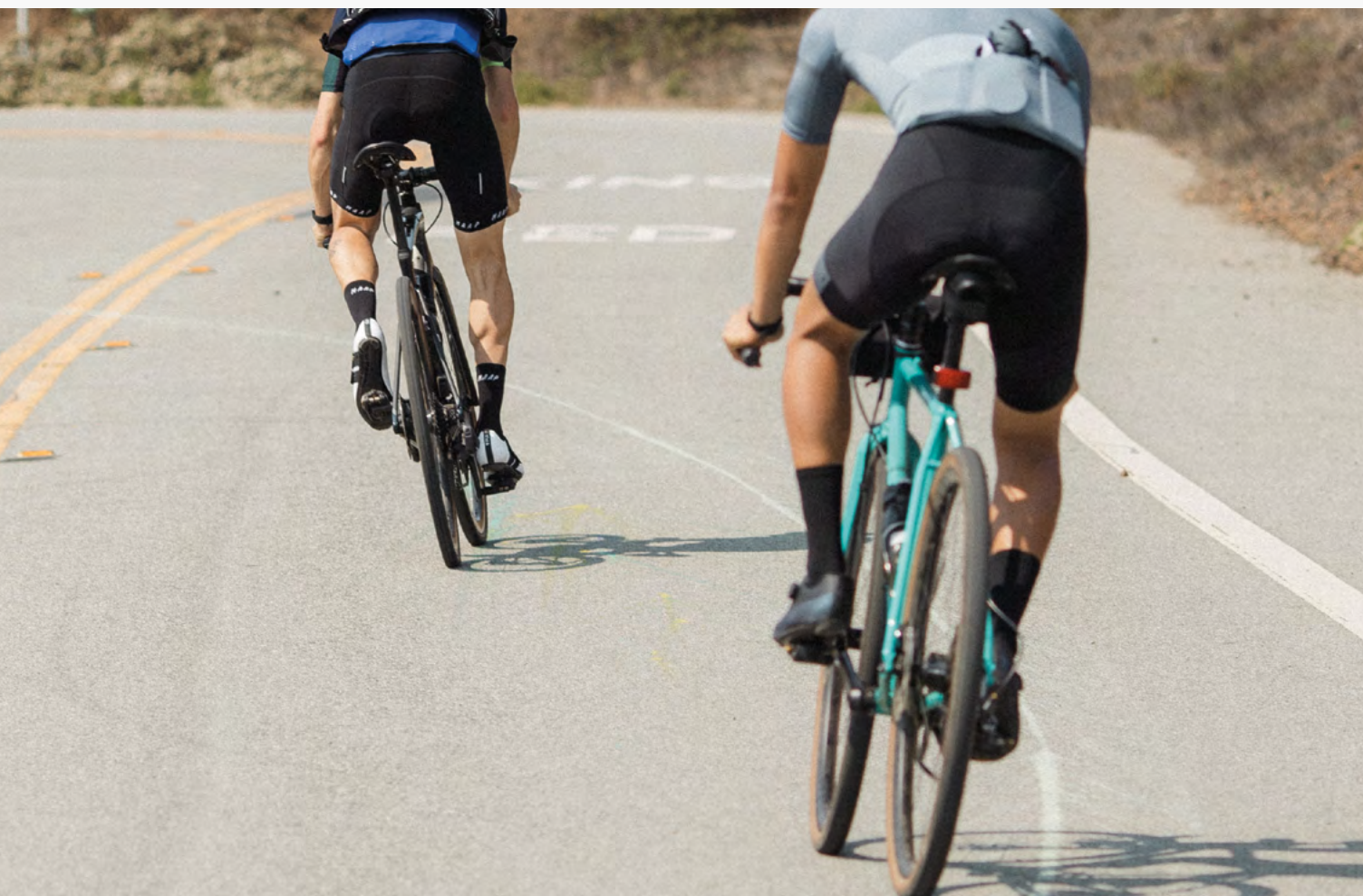

**TEMPO**  
**ARGO R1**

Intended use: ROAD

**Regular**

L 260mm | W 150mm | W 195g

**Large**

L 260mm | W 160mm | W 202g



**TEMPO**  
**ARGO R3**

Intended use: ROAD

**Regular**

L 260mm | W 150mm | W 229g

**Large**

L 260mm | W 160mm | W 235g



**TEMPO**  
**ARGO R5**

Intended use: ROAD

**Regular**

L 260mm | W 150mm | W 241g

**Large**

L 260mm | W 160mm | W 247g



ARTICLE	EAN	MODEL	SIZE	COLOR	RAILS	SHELL	PADDING	SRP (€)
70D9S00A03A23	8021890486547	<b>Tempo Argo R1</b>	<b>150mm</b>	Black	Carbon Mobius 7x9mm	Carbon Reinforced Nylon with WingFlex	Type 2	199
70E0S00A03A23	8021890486578		<b>160mm</b>					199
70D9S00A13A22	8021890486554	<b>Tempo Argo R3</b>	<b>150mm</b>	Black	Kium 7x7mm	Carbon Reinforced Nylon with WingFlex	Type 2	149
70E0S00A13A22	8021890486585		<b>160mm</b>					149
70D9S00A23A22	8021890486561	<b>Tempo Argo R5</b>	<b>150mm</b>	Black	S-Alloy 7x7mm	Carbon Reinforced Nylon with WingFlex	Type 2	109
70E0S00A23A22	8021890486592		<b>160mm</b>					109

# ANTARES

Antares is a high-performance saddle with a streamlined shape and tapered nose-to-wing transition designed to allow a responsive feeling in every racing condition.

Antares ist ein High-Performance Sattel mit stromlinienförmigem Design und einem konisch zulaufenden Übergang von der Nase zu den Seitenflächen, der in jeder Rennsituation ein reaktionsfreudiges Gefühl vermittelt.



**VENTO**  
**ANTARES 00**

Intended use: ROAD RACING, XC, CX

**Regular**

L 270mm | W 140mm | W 118g

**Large**

L 270mm | W 150mm | W 124g



**VENTO**  
**ANTARES R1**

Intended use: ROAD RACING, XC, CX

**Regular**

L 268mm | W 140mm | W 161g

**Large**

L 268mm | W 150mm | W 166g



**VENTO**  
**ANTARES R3**

Intended use: ROAD RACING, XC, CX

**Regular**

L 268mm | W 140mm | W 195g

**Large**

L 268mm | W 150mm | W 202g



**VENTO**  
**ANTARES R5**

Intended use: ROAD RACING, XC, CX

**Regular**

L 268mm | W 140mm | W 210g

**Large**

L 268mm | W 150mm | W 217g



ARTICLE	EAN	MODEL	SIZE	COLOR	RAILS	SHELL	PADDING	SRP (€)
77E9Y00A0E000	8021890580375	<b>Vento Antares 00</b>	<b>140mm</b>	Black	Carbon 7x9mm	Full Carbon Shell	Injected EVA	299
77F0Y00A0E000	8021890580382		<b>150mm</b>					299
75E5S00A03A25	8021890580191	<b>Vento Antares R1</b>	<b>140mm</b>	Black	Carbon 7x9mm	Carbon Reinforced Nylon with WingFlex	Double-density foam	199
75E6S00A03A25	8021890580221		<b>150mm</b>					199
75E5S00A13A25	8021890580207	<b>Vento Antares R3</b>	<b>140mm</b>	Black	Kium 7x7mm	Carbon Reinforced Nylon with WingFlex	Double-density foam	149
75E6S00A13A25	8021890580238		<b>150mm</b>					149
75E5S00A23A25	8021890580214	<b>Vento Antares R5</b>	<b>140mm</b>	Black	S-Alloy 7x7mm	Carbon Reinforced Nylon with WingFlex	Double-density foam	109
75E6S00A23A25	8021890580245		<b>150mm</b>					109



# ALIANTE

Aliante is an endurance road cycling saddle with a waved profile designed to maximize comfort, featuring a pressure-relieving cutout and double-density foam that make even the longest rides enjoyable.

Der Aliante ist ein Langstrecken-Rennradsattel mit einem geschwungenen Profil, das auf maximalen Komfort ausgelegt ist. Er verfügt über eine druckentlastende Aussparung und einen Schaum mit zwei unterschiedlichen Dichten, wodurch selbst die längsten Fahrten zum Vergnügen werden.



**TEMPO**  
**ALIANTE R1**

Intended use: ROAD

**Regular**

L 277mm | W 145mm | W 180g

**Large**

L 277mm | W 155mm | W 186g



**TEMPO**  
**ALIANTE R3**

Intended use: ROAD

**Regular**

L 277mm | W 145mm | W 220g

**Large**

L 277mm | W 155mm | W 226g



**TEMPO**  
**ALIANTE R5**

Intended use: ROAD

**Regular**

L 277mm | W 145mm | W 230g

**Large**

L 277mm | W 155mm | W 236g



ARTICLE	EAN	MODEL	SIZE	COLOR	RAILS	SHELL	PADDING	SRP (€)
75E7S00A03A25	8021890580252	<b>Tempo Aliante R1</b>	<b>145mm</b>	Black	Carbon 7x9mm	Carbon Reinforced Nylon with WingFlex	Double-density foam	199
75E8S00A03A25	8021890580283		<b>155mm</b>					199
75E7S00A13A25	8021890580269	<b>Tempo Aliante R3</b>	<b>145mm</b>	Black	Kium 7x7mm	Carbon Reinforced Nylon with WingFlex	Double-density foam	149
75E8S00A13A25	8021890580290		<b>155mm</b>					149
75E7S00A23A25	8021890580276	<b>Tempo Aliante R5</b>	<b>145mm</b>	Black	S-Alloy 7x7mm	Carbon Reinforced Nylon with WingFlex	Double-density foam	109
75E8S00A23A25	8021890580306		<b>155mm</b>					109

# ARIONE

Arione is a flat profile saddle designed for riders with high body flexibility and no pelvic rotation whilst pedalling.

Arione ist ein Sattel mit flachem Profil, der für Fahrer mit hoher Körperflexibilität und ohne Beckenrotation beim Treten entwickelt wurde.



## ARIONE 00

Intended use: ROAD RACING

L 298mm | W 124mm | W 140g



## ARIONE R1

Intended use: ROAD RACING

Regular

L 300mm | W 126mm | W 165g

Large

L 300mm | W 140mm | W 175g



## ARIONE R3

Intended use: ROAD RACING

Regular

L 300mm | W 126mm | W 200g

Large

L 300mm | W 140mm | W 210g



## ARIONE CLASSIC

Intended use: ROAD RACING

L 300mm | W 132mm | W 235g



ARTICLE	EAN	MODEL	SIZE	COLOR	RAILS	SHELL	PADDING	SRP (€)
7092SWSA19C65	8021890428127	<b>Arione 00</b>	-	Black/ Anthracite	Carbon Mobius 7x10mm	Full Carbon	Type 1	299
76B5SWSA09C65	8021890443861	<b>Arione R1</b>	<b>Regular</b>	Black	Carbon Braided 7x10mm	Thermoplastic Carbon Composite with WingFlex	Type 1	199
76BOSWSA09E12	8021890443830		<b>Large</b>					199
74B5SWSA09F04	8021890443816	<b>Arione R3</b>	<b>Regular</b>	Black	Kium 7x7mm	Thermoplastic Carbon Composite with WingFlex	Type 1	149
74BOSWSA09C65	8021890443786		<b>Large</b>					149
7014SXSD99640	8021890276308	<b>Arione Classic</b>	-	Black	Kium 7x7mm	Carbon Reinforced Nylon with WingFlex	Type 1	129

# ARIONE OPEN

Open is an handmade construction for optimal power transfer combined a cutaway design that relief pressure on soft tissue.

Open ist eine handgefertigte Konstruktion für optimale Kraftübertragung in Kombination mit einem Cutaway-Design, das den Druck auf das Weichteilgewebe verringert.



## ARIONE R1 OPEN

Intended use: ROAD RACING

**Regular**

L 300mm | W 132mm | W 199g

**Large**

L 298mm | W 142mm | W 205g



## ARIONE R3 OPEN

Intended use: ROAD

**Regular**

L 300mm | W 132mm | W 230g

**Large**

L 298mm | W 142mm | W 240g



ARTICLE	EAN	MODEL	SIZE	COLOR	RAILS	SHELL	PADDING	SRP (€)
70COS00A03A02	8021890455642	<b>Arione R1 Open</b>	<b>Regular</b>	Black	Carbon Braided 7x10mm	Carbon Reinforced Nylon with WingFlex	Type 1	199
70DOS00A03A02	8021890455703		<b>Large</b>					199
70COS00A13041	8021890455659	<b>Arione R3 Open</b>	<b>Regular</b>	Black	Kium 7x7mm	Carbon Reinforced Nylon with WingFlex	Type 1	149
70DOS00A13041	8021890455710		<b>Large</b>					149
70COS00A13038	8021890460233	<b>Arione R3 Open</b>	<b>Regular</b>	White	Kium 7x7mm	Carbon Reinforced Nylon with WingFlex	Type 1	149
70DOS00A13038	8021890460264		<b>Large</b>					149

## AERIS LONG DISTANCE

A split-nose triathlon saddle designed to provide greater support and stability when riding in forward, aerodynamic racing positions.

Ein Triathlon-Sattel mit geteiltem Nasenbereich, der entwickelt wurde, um mehr Halt und Stabilität beim Fahren in einer nach vorne gerichteten, aerodynamischen Rennposition zu bieten.



**TRANSIRO**  
**AERIS LD R1**

Intended use: TRIATHLON / TIME TRIAL

L 244mm | W 135mm | W 181g



**TRANSIRO**  
**AERIS LD R3**

Intended use: TRIATHLON / TIME TRIAL

L 244mm | W 135mm | W 212g



**TRANSIRO**  
**AERIS LD R5**

Intended use: TRIATHLON / TIME TRIAL

L 244mm | W 135mm | W 218g



ARTICLE	EAN	MODEL	SIZE	COLOR	RAILS	SHELL	PADDING	SRP (€)
75F3S00A03A25	8021890580313	<b>Transiro AERIS LD R1</b>	<b>135mm</b>	Black	Carbon 7x9mm	Carbon Reinforced Nylon	Type 1	199
75F3S00A13A25	8021890580320	<b>Transiro AERIS LD R3</b>	<b>135mm</b>	Black	Kium 7x7mm	Carbon Reinforced Nylon	Type 1	149
75F3S00A23A25	8021890580337	<b>Transiro AERIS LD R5</b>	<b>135mm</b>	Black	S-Alloy 7x7mm	Carbon Reinforced Nylon	Type 1	109



## AERIS SHORT DISTANCE

A saddle designed to encourage maximum stability and support for time trialists and triathletes requiring an optimal platform from which to deliver power while in forward, aerodynamic riding positions.

Ein Sattel, der maximale Stabilität und Unterstützung für Zeitfahrer und Triathleten zu bieten, die nach einem Sattel suchen, von dem aus sie ihre Kraft in einer aerodynamischen, nach vorne gerichteten Sitzhaltung ausüben können.



**TRANSIRO**  
**AERIS SD R1**

Intended use: TRIATHLON / TIME TRIAL

L 245mm | W 135mm | W 170g



**TRANSIRO**  
**AERIS SD R3**

Intended use: TRIATHLON / TIME TRIAL

L 245mm | W 135mm | W 199g



**TRANSIRO**  
**AERIS SD R5**

Intended use: TRIATHLON / TIME TRIAL

L 245mm | W 135mm | W 209g



ARTICLE	EAN	MODEL	SIZE	COLOR	RAILS	SHELL	PADDING	SRP (€)
75F4S00A03A25	8021890580344	<b>Transiro Aeris SD R1</b>	<b>135mm</b>	Black	Carbon 7x9mm	Carbon Reinforced Nylon	Type 1	199
75F4S00A13A25	8021890580351	<b>Transiro Aeris SD R3</b>	<b>135mm</b>	Black	Kium 7x7mm	Carbon Reinforced Nylon	Type 1	149
75F4S00A23A25	8021890580368	<b>Transiro Aeris SD R5</b>	<b>135mm</b>	Black	S-Alloy 7x7mm	Carbon Reinforced Nylon	Type 1	109

# OFF-ROAD SADDLES



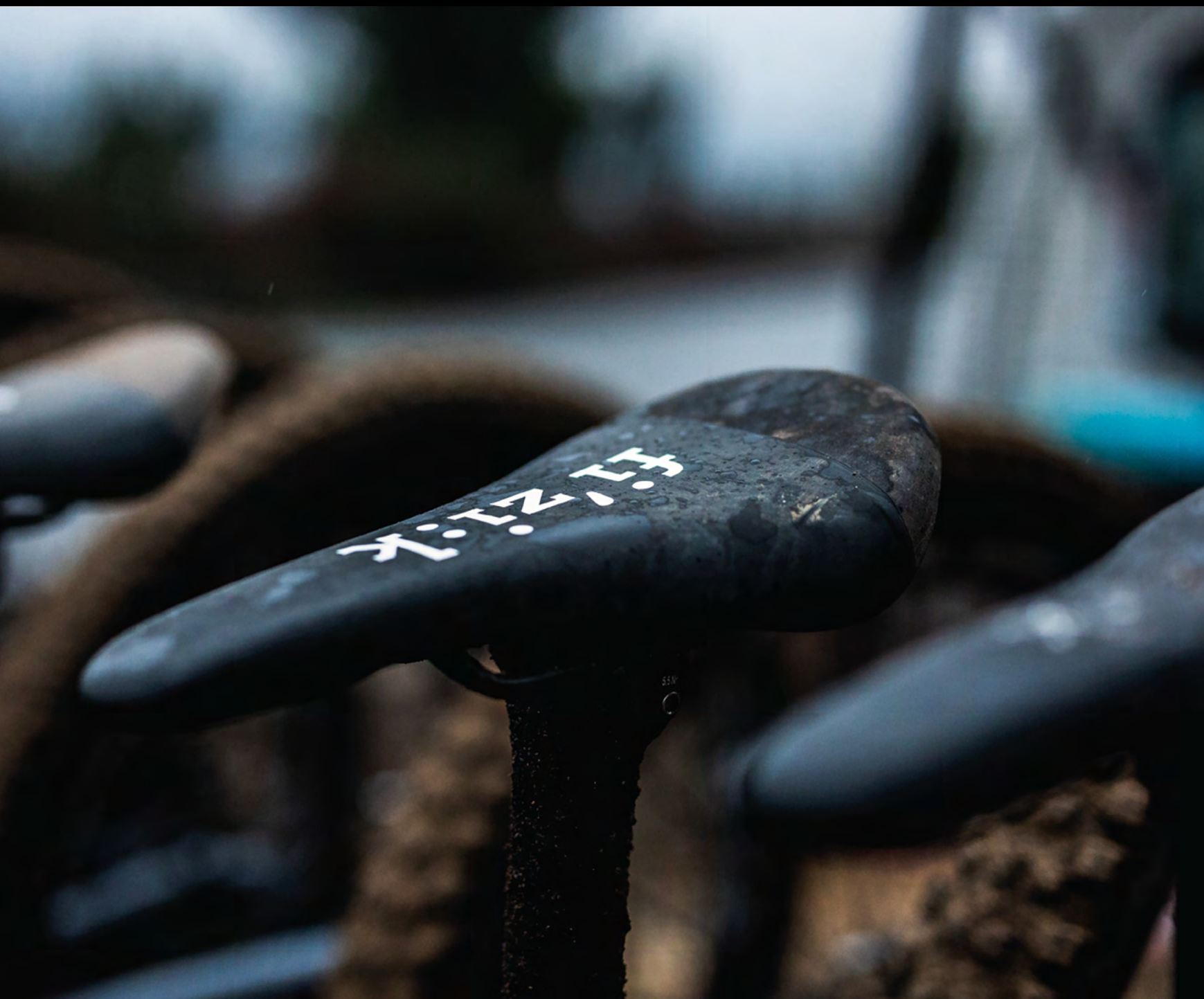

## VENTO ARGO X NEW

A performance off-road racing saddle with a short-nose design that improves stability and allows for a more aggressive riding position.

Ein leistungsstarker Geländesattel mit kurznasigem Design, das die Stabilität verbessert und eine aggressivere Sitzposition ermöglicht.



**VENTO**  
**ARGO X1**

Intended use: OFF-ROAD RACING

**Regular**

L 265mm | W 140mm | W 192g

**Large**

L 265mm | W 150mm | W 198g



**VENTO**  
**ARGO X3**

Intended use: OFF-ROAD RACING

**Regular**

L 265mm | W 140mm | W 231g

**Large**

L 265mm | W 150mm | W 237g



**VENTO**  
**ARGO X5**

Intended use: OFF-ROAD RACING

**Regular**

L 265mm | W 140mm | W 240g

**Large**

L 265mm | W 150mm | W 246g



ARTICLE	EAN	NEW	MODEL	SIZE	COLOR	RAILS	SHELL	PADDING	SRP (€)
F212URNA27881	6957312803291	<b>NEW</b>	<b>Vento Argo X1</b>	<b>140mm</b>	Black	Carbon 7x9mm	Fiber Reinforced Nylon with WingFlex	Type 1	199
F213URNA27881	6957312803314	<b>NEW</b>		<b>150mm</b>					199
F212URNA17881	6957312803277	<b>NEW</b>	<b>Vento Argo X3</b>	<b>140mm</b>	Black	Kium 7x7mm	Fiber Reinforced Nylon with WingFlex	Type 1	149
F213URNA17881	6957312803284	<b>NEW</b>		<b>150mm</b>					149
F212URNA07881	6957312803253	<b>NEW</b>	<b>Vento Argo X5</b>	<b>140mm</b>	Black	S-Alloy 7x7mm	Fiber Reinforced Nylon with WingFlex	Type 1	109
F213URNA07881	6957312803260	<b>NEW</b>		<b>150mm</b>					109

## TERRA ARGO

As the gravel-specific option, the Terra Argo has been engineered with a compliant shell to offer a certain degree of flexibility. This controlled elasticity absorbs road chatter and vibrations, delivering the comfort needed for long distance riding over unpaved roads.

Ausgelegt für Gravel Fahrten wurde der Terra Argo mit einer nachgiebigen Schale konstruiert, um ein gewisses Maß an Flexibilität zu bieten. Diese kontrollierte Elastizität absorbiert Klappern und Vibrationen auf der Straße und bietet den Komfort, der für Langstreckenfahrten über unbefestigte Straßen erforderlich ist.



**TERRA**  
**ARGO X1**

Intended use: GRAVEL

**NEW SIZE**

L 270mm | W 140mm | W 210g

**Regular**

L 270mm | W 150mm | W 215g

**Large**

L 270mm | W 160mm | W 225g



**TERRA**  
**ARGO X3**

Intended use: GRAVEL

**NEW SIZE**

L 270mm | W 140mm | W 253g

**Regular**

L 270mm | W 150mm | W 258g

**Large**

L 270mm | W 160mm | W 262g



**TERRA**  
**ARGO X5**

Intended use: GRAVEL

**NEW SIZE**

L 270mm | W 140mm | W 265g

**Regular**

L 270mm | W 150mm | W 271g

**Large**

L 270mm | W 160mm | W 275g



ARTICLE	EAN	NEW	MODEL	SIZE	COLOR	RAILS	SHELL	PADDING	SRP (€)
70F9S00A03A22	8021890590077	<b>NEW</b>	<b>Terra Argo X1</b>	<b>140mm</b>	Black	Carbon 7x9mm	Carbon Reinforced Nylon with WingFlex	Type 2	199
70E1S00A23A22	8021890571199			<b>150mm</b>					199
70E2S00A23A22	8021890571205			<b>160mm</b>					199
70F9S00A13A22	8021890590084	<b>NEW</b>	<b>Terra Argo X3</b>	<b>140mm</b>	Black	Kium Mobius 7x7mm	Carbon Reinforced Nylon with WingFlex	Type 2	149
70E1S00A03A22	8021890498052			<b>150mm</b>					149
70E2S00A03A22	8021890498076			<b>160mm</b>					149
70F9S00A23A22	8021890590091	<b>NEW</b>	<b>Terra Argo X5</b>	<b>140mm</b>	Black	S-Alloy Mobius 7x7mm	Carbon Reinforced Nylon with WingFlex	Type 2	109
70E1S00A13A22	8021890486615			<b>150mm</b>					109
70E2S00A13A22	8021890486639			<b>160mm</b>					109



# ALPACA

A mountain biking saddle with smooth-edged shape that combines support and riding control for dropper post use.

Ein Mountainbike-Sattel mit einer glattkantigen Form, die Unterstützung und Fahrkontrolle für die Verwendung von dropper post-Sattelstützen kombiniert.



**TERRA**  
**ALPACA X5**  
**+ CARRIAGE KIT**

Intended use: ENDURO, ALL-MOUNTAIN

L 248mm | W 145mm | W 230g



**GRAVITA**  
**ALPACA X5**  
**+ CARRIAGE KIT**

Intended use: ENDURO, DOWNHILL

L 251mm | W 130mm | W 216g

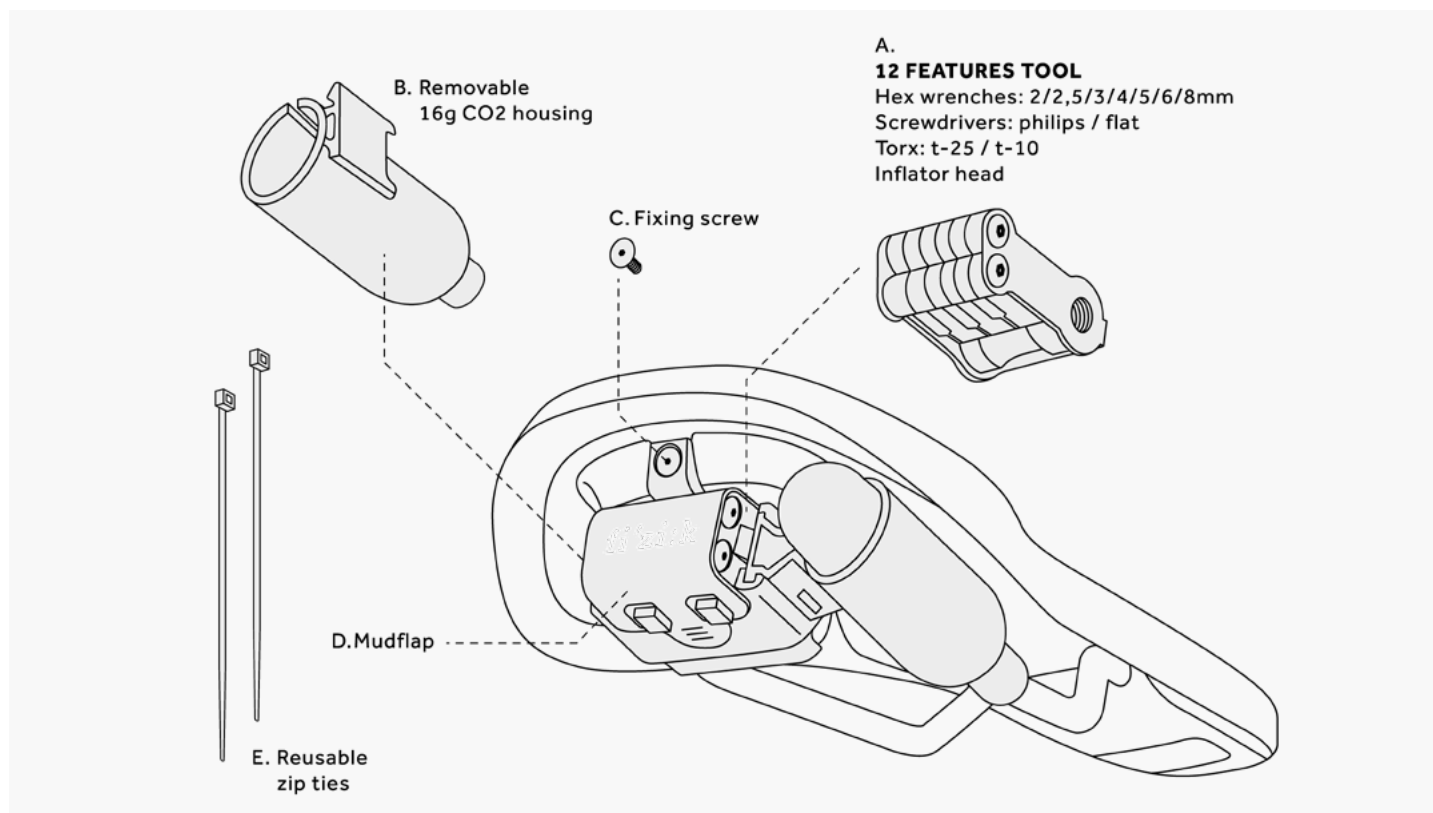

ARTICLE	EAN	MODEL	COLOR	RAILS	SHELL	PADDING	SRP (€)
F206URNA13814	6957312802447	<b>Terra Alpaca X5 + Carriage Kit</b>	Black	S-Alloy Mobius 7x7mm	Fiber Reinforced Nylon with EdgeFlex	Type 1	109
F205URNA13814	6957312802430	<b>Gravita Alpaca X5 + Carriage Kit</b>	Black	S-Alloy Mobius 7x7mm	Fiber Reinforced Nylon with EdgeFlex	Type 1	99

# AIDON

Aidon is a saddle shape designed around the needs of pedal assisted riding.

Aidon ist eine Sattelform, die speziell auf die Bedürfnisse des Pedalunterstützten Fahrens zugeschnitten ist.



**TERRA**  
**AIDON X1**

Intended use: E-MTB

**Regular**

L 255mm | W 145mm | W 205g

**Large**

L 255mm | W 160mm | W 215g



**TERRA**  
**AIDON X3**

Intended use: E-MTB

**Regular**

L 255mm | W 145mm | W 249g

**Large**

L 255mm | W 160mm | W 259g



**TERRA**  
**AIDON X5**

Intended use: E-MTB

**Regular**

L 255mm | W 145mm | W 262g

**Large**

L 255mm | W 160mm | W 272g



ARTICLE	EAN	MODEL	SIZE	COLOR	RAILS	SHELL	PADDING	SRP (€)
F208URNA24873	6957312802485	<b>Terra Aidon X1</b>	<b>145mm</b>	Black	Carbon Mobius 7x9mm	Fiber Reinforced Nylon with WingFlex	Type 2	179
F209URNA24873	6957312802515		<b>160mm</b>					179
F208URNA14873	6957312802478	<b>Terra Aidon X3</b>	<b>145mm</b>	Black	Kium Mobius 7x7mm	Fiber Reinforced Nylon with WingFlex	Type 2	139
F209URNA14873	6957312802508		<b>160mm</b>					139
F208URNA04873	6957312802461	<b>Terra Aidon X5</b>	<b>145mm</b>	Black	S-Alloy Mobius 7x7mm	Fiber Reinforced Nylon with WingFlex	Type 2	89
F209URNA04873	6957312802492		<b>160mm</b>					89

**VENTO**  
**ANTARES**  
**TEST KIT**

1 Vento Antares R5 140  
1 Vento Antares R5 150



**TEMPO**  
**ALIANTE**  
**TEST KIT**

1 Tempo Aliante R5 145  
1 Tempo Aliante R5 155



**TRANSIRO**  
**AERIS**  
**TEST KIT**

1 Transiro Aeris SD R5  
1 Transiro Aeris LD R5



**VENTO & TEMPO**  
**ARGO**  
**TEST KIT**

1 Vento Argo R3 140  
1 Vento Argo R3 150  
1 Tempo Argo R3 150  
1 Tempo Argo R3 160



**TERRA**  
**ARGO**  
**TEST KIT**

1 Terra Argo X3 150  
1 Terra Argo X3 160



ARTICLE	EAN	MODEL	DESCRIPTION
FZKS000D30000	8021890580399	<b>Vento Antares Test Kit</b>	2 Vento Antares R5, both sizes, test cosmetics
FZKS000D40000	8021890580405	<b>Tempo Aliante Test Kit</b>	2 Tempo Aliante R5, both sizes, test cosmetics
FZKS000D50000	8021890580412	<b>Transiro Aeris Test Kit</b>	1x Transiro Aeris SD R5 and 1x Transiro Aeris LD R5, test cosmetics
FZKS000000000	8021890486448	<b>Vento &amp; Tempo Argo Test Kit</b>	4 R3 Vento e Tempo Argo Test Saddles (2 Regular + 2 Large)
FZKS000C50000	8021890498397	<b>Terra Argo Test Kit</b>	2 X3 Terra Argo Test Saddles (1 Regular + 1 Large)

## SADDLE BAG SMALL

Designed to carry an inner tube, CO2, tire levers.  
Made in durable PU-coated polyester with welded seams.

- Inner mesh pocket
- Water-repellent zipper
- Fits the underside of the saddle with a Velcro strap
- Volume 0,4L
- Dimensions 110x75x50 mm
- Weight: 66g



Entwickelt für die Aufnahme eines Schlauches, einer CO2 Kartusche und Reifenhebern.

Aus haltbarem PU-beschichtetem Polyester mit verschweißten Nähten.

- Innenliegende Netztasche
- wasserabweisender Reißverschluss
- Befestigung an der Unterseite des Sattels mit einem Klettband
- Volumen 0,4L
- Abmessungen 110x75x50mm
- Gewicht: 66g



## AERIS LINK

**NEW**

Weight: 14g

Enables rear attachment of a water bottle cage to Aeris SD and LD saddles.

Ermöglicht die rückseitige Befestigung eines Flaschenhalters an den Aeris SD und LD Sätteln.



## BOTTLE CAGE

Weight: 29g

Developed to be integrated with the Aeris saddle link, this bottle cage is compatible with all standard, 2-hole threaded cage mounts.

Entwickelt, um am Aeris-Sattelgestell integriert zu werden, ist dieser Flaschenhalter kompatibel mit allen standardmäßigen 2-Loch Flaschenhalteraufnahmen.



ARTICLE	EAN	NEW	MODEL	SIZE	COLOR	DESCRIPTION	SRP (€)
FB09000A00000	8021890497130		<b>fi'zi:k Saddle Bag</b>	One Size	Black	PU-coated polyester / inner mesh pocket / water repellent zipper / velcro straps	25
FZKS000D70000	8021890586698	<b>NEW</b>	<b>fi'zi:k Aeris Link</b>	One Size	Black	Enables rear attachment of a water bottle cage to Aeris SD and LD saddles	15
FZKS000D20000	8021890497130		<b>fi'zi:k Bottle Cage</b>	One Size	Black	Designed to be integrated with the Aeris saddle link, the bottle cage is compatible with all bike frames with standard 2 threaded holes	15

# **SADDLE FINDER**

SHOP SERIES DROPS STORIES ATHLETES

fi'zi:k

## SADDLE FINDER

**SECTION 1: RIDING GOALS**

What is the intended use for the saddle you're looking for?

Select

How often do you ride your bike?

Select

At fizik we believe in providing the best riding experience possible, improving health, comfort and performance.

To help you **choose your ideal saddle**, we have created a simple tool which can guide you through the process.

Wir bei fizik wollen Ihnen das bestmögliche Fahrerlebnis bieten und dabei Ihr Wohlbefinden, Ihren Komfort und Ihre Leistungsfähigkeit verbessern.

Um Sie bei der Wahl des **für Sie optimal geeigneten Sattels** zu unterstützen, haben wir ein einfaches Tool entwickelt, welches Sie durch den Auswahlprozess führt.

Find out more at [www.fizik.com](http://www.fizik.com)  
or scan the code.

Mehr unter [www.fizik.com](http://www.fizik.com)  
oder einfach den Code scannen.





# SHOES



# CLOSURE SYSTEMS

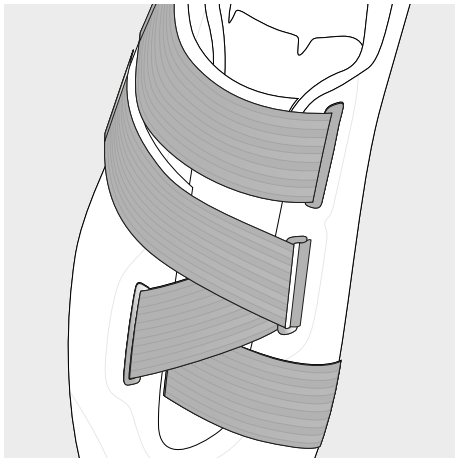

## POWERSTRAP

Is an innovative Velcro closure designed for an enveloping fit. While most Velcro closures simply pull together two sides of the shoe's upper, in this configuration a ribbon wraps around the foot, enabling ultimate comfort and containment using just two straps.

Ist ein innovativer Klettverschluss, der für eine umhüllende Passform entwickelt wurde. Während die meisten Klettverschlüsse einfach zwei Seiten des Schuhobermaterials zusammenziehen, wickelt sich in dieser Konstruktion ein breites Band um den Fuß und ermöglicht so ultimativen Komfort und Halt mit nur zwei Streifen.

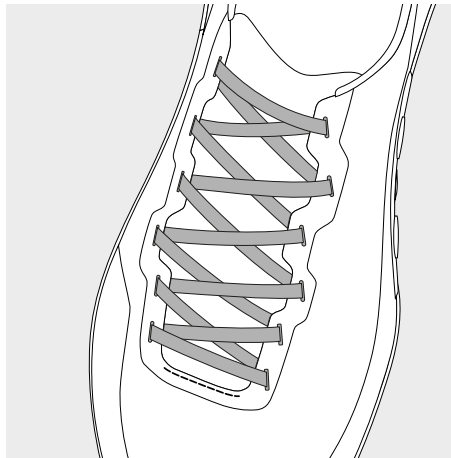

## LACE

Laces cradle the foot and adapt to a variety of foot shapes, securing the fit with a more natural feel. With laces, pressure is spread evenly across the entire foot, without any hotspots.

Schnürsenkel umschließen den Fuß und passen sich den unterschiedlichsten Fußformen an, wodurch die Passform mit einem natürlicheren Gefühl verstärkt wird. Mit Schnürsenkeln wird der Druck gleichmäßig über den gesamten Fuß verteilt, ohne störende Druckstellen.

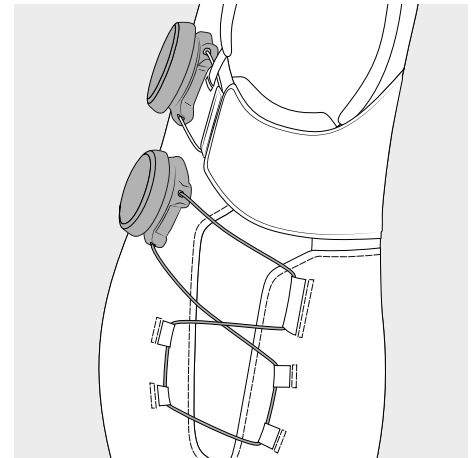

## DOUBLE BOA

Allows a differentiated fit adjustment for the instep and forefoot areas – the shape and volume of which can vary widely between riders. By controlling two separate BOA dials, cyclists can fine-tune shoe fit to their unique foot shape for customized comfort and support.

Ermöglicht eine separate Einstellung der Passform für den Rist- und Vorfußbereich, deren Form und Volumen von Fahrer zu Fahrer stark variieren kann. Über zwei separate BOA-Drehknöpfe können Radfahrer die Passform des Schuhs auf ihre individuelle Fußform abstimmen und so für maßgeschneiderten Komfort und Unterstützung sorgen.

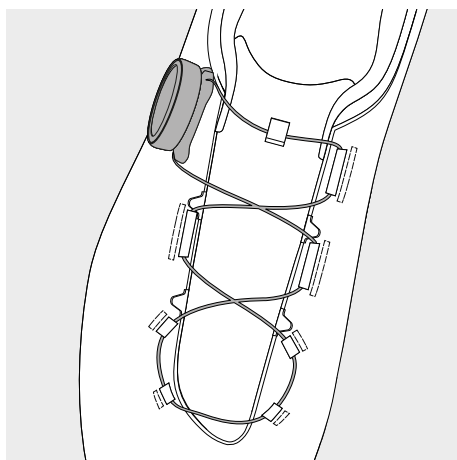

## SINGLE BOA

A fast and secure closure system, powered by a micro-adjustable BOA dial for a fine tuned fit.

Ein schnelles und zuverlässiges Verschlusssystem, das mit einem mikroverstellbaren BOA-Drehknopf für eine fein abstimmbare Passform sorgt.

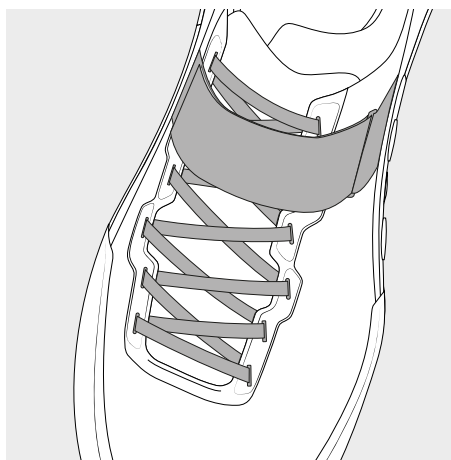

## LACES + STRAP

An ergonomic lace-up pattern that cradles the foot and spreads tension evenly throughout the pedal stroke. Powerstrap over the instep secures the fit by stabilizing the plantar arch and locking the heel in place while also keeping the laces in check.

Ein ergonomisch gestaltetes Schnürsystem, das den Fuß umschließt und die Druckverteilung während des Pedalierens gleichmäßig verteilt. Der Powerstrap über dem Spann garantiert eine optimale Passform, indem er das Fußgewölbe stabilisiert und die Ferse im Schuh fixiert, während er gleichzeitig die Schnürsenkel in Schach hält.

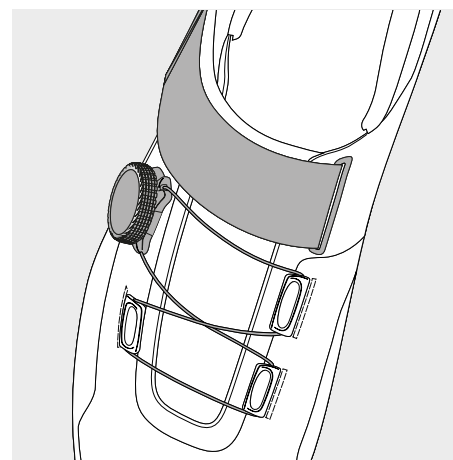

## STRAP + BOA

Dual closure system with a Velcro strap and a BOA dial. At the instep, a strap provides exceptional foot containment, while at the same time providing a fail-proof system. A BOA® Fit System is further located at the fore-foot, ensuring a micro-adjustable precision fit.

Doppeltes Verschlusssystem mit einem Klettverschluss und einem BOA-Drehknopf. Am Rist sorgt ein Strap für außergewöhnlichen Halt des Fußes, während er gleichzeitig ein verlässliches und sicheres System darstellt. Ein BOA® Fit System befindet sich außerdem am Vorfuß und sorgt für eine mikrojustierbare Passgenauigkeit.

# UPPER MATERIALS

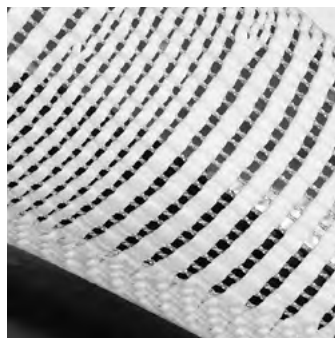

## AEROWEAVE

It's an advanced woven fabric that interlaces lightweight nylon fibers with filaments of thermoplastic polymer. This blend of threads creates a material with an open, net-like pattern that is extremely airy, yet highly resistant and resilient. Aeroweave is a malleable material, and moves to effectively cradle the foot, but its tenacity delivers the support and containment required for a high performance racing shoe.

Es handelt sich um ein fortschrittliches Gewebe, bei dem leichte Nylonfasern mit Filamenten aus thermoplastischem Polymer verflochten sind. Durch diese Mischung von Fäden entsteht ein Material mit einem offenen, netzartigen Muster, das extrem luftig und dennoch sehr widerstandsfähig und elastisch ist. Aeroweave ist ein formbares Material, das in der Lage ist den Fuß effektiv zu halten, aber dank seiner Festigkeit die Unterstützung liefert, die für einen Hochleistungs-Rennschuh erforderlich ist.

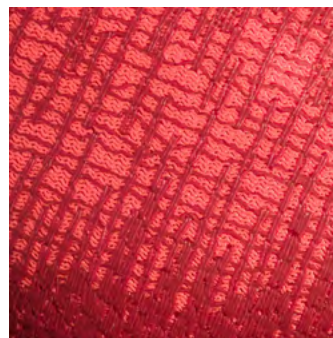

## KNIT

Uppers created using electronic knitting machines which accurately link loops of yarn on needles and can seamlessly change the yarn direction of the fabric to create different stitching patterns. This process produces distinct functional zones, with engineered performance in key areas, such as vents and mesh openings for enhanced breathability.

Obermaterialien, die mit elektronischen Strickmaschinen hergestellt werden, welche die Garnschlingen auf den Nadeln präzise verbinden und die Garnrichtung des Stoffes nahtlos ändern können, um verschiedene Nähmuster zu erzeugen. Durch diesen Prozess entstehen eigenständige Funktionszonen, die in Schlüsselbereichen, wie Belüftungen und Mesh-Öffnungen für eine verbesserte Atmungsaktivität sorgen.

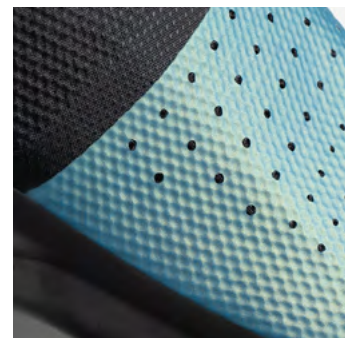

## PU LAMINATED

Upper made of a resilient polyurethane-laminated material combined over a comfortable mesh, resulting in reduced yield and providing longlasting foot support and enhanced ventilation where it's needed most.

Das Obermaterial besteht aus einem elastischen Polyurethan-Laminat, das mit einem komfortablen Mesh-Material kombiniert ist. Dadurch wird die Nachgiebigkeit reduziert, der Fuß wird dauerhaft gestützt und die Belüftung dort verbessert, wo sie am dringendsten benötigt wird.



## MICROTEX

Synthetic leather-like upper material that is supple yet strong and durable for a comfortable and consistent fit.

Synthetiklederähnliches Obermaterial, das geschmeidig und dennoch robust und strapazierfähig ist und eine komfortable und beständige Passform bietet.



## RIPSTOP

Ripstop is a light and hardwearing woven fabric with high resistance to rips and tears. During weaving, stronger reinforcement yarns are interwoven at regular intervals in a crosshatch pattern to reduce spreading.

Ripstop ist ein leichtes und strapazierfähiges Gewebe mit hoher Riss- und Reißfestigkeit. Beim Weben werden in regelmäßigen Abständen stärkere Verstärkungsfäden in einem kreuzförmigen Muster verwoben, um ein Aufspreizen zu verhindern.

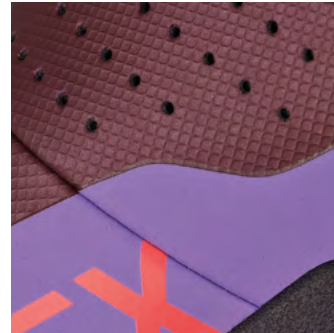

## GORE-TEX

The breathable, waterproof GORE-TEX membrane keeps feet dry in any weather while allowing sweat vapor to escape easily. In our winter shoes, a softbrushed fleece lining adds warmth and comfort on cold rides.

Die atmungsaktive, wasserdichte GORE-TEX-Membran hält die Füße bei jedem Wetter trocken und lässt gleichzeitig Schweißdämpfe leicht entweichen. In unseren Winterschuhen sorgt ein weiches, gebürstetes Fleece-Futter für Wärme und Komfort bei Fahrten an kalten Tagen.



## 3D AIR MESH

A mesh upper construction, highly breathable and soft, that helps keep feet dry and enhance ventilation.

Das hoch atmungsaktive und weiche Mesh-Obermaterial hält die Füße trocken und verbessert die Luftzirkulation.

# ROAD OUTSOLES

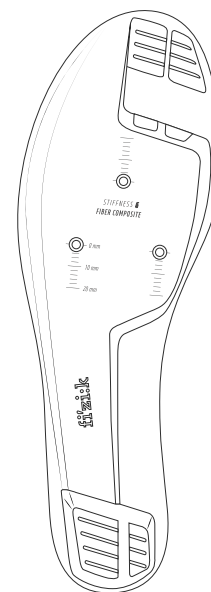
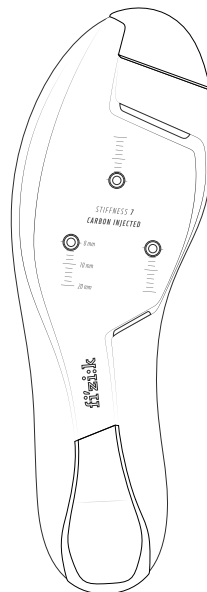
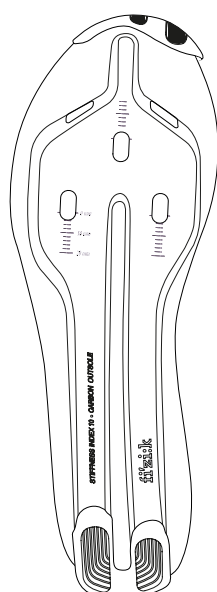
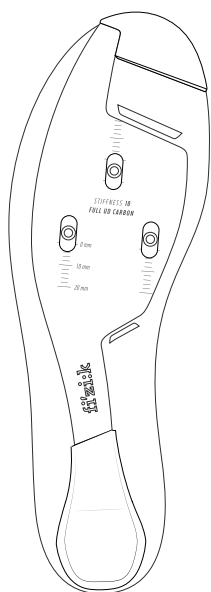

## R2

### STIFFNESS INDEX 10

R2 carbon outsole: optimized cleat positioning, high stiffness and lightness tuned for power transfer.

### STEIFIGKEITSINDEX 10

R2 Carbon-Außensohle: optimierte Positionierung der Cleats, hohe Steifigkeit und Leichtigkeit abgestimmt auf die Kraftübertragung.

## R3

### STIFFNESS INDEX 10

The ultimate in stiffness and lightness. A carbon outsole for optimized cleat positioning and tuned for maximum power transfer.

### STEIFIGKEITSINDEX 10

Das ultimative Maß an Steifigkeit und Leichtigkeit. Eine Carbonsohle zur optimierten Cleat-Positionierung und abgestimmt für maximalen Krafttransfer.

## R4

### STIFFNESS INDEX 7

R4 carbon injected outsole: moderately stiff for efficient power transfer in comfort.

### STEIFIGKEITSINDEX 7

R4 Carbon-Injected-Außensohle: mäßig steif für eine effiziente Kraftübertragung und Komfort.

## R5

### STIFFNESS INDEX 6

R5 nylon composite outsole: delivers balance between comfort and pedalling efficiency.

### STEIFIGKEITSINDEX 6

R5 Nylon-Verbund-Laufsohle: bietet ein ausgewogenes Verhältnis zwischen Komfort und Treteffizienz.



# OFF-ROAD OUTSOLES

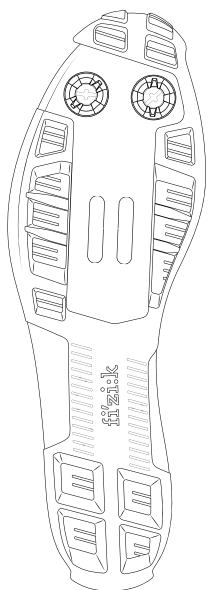

## X1

### STIFFNESS INDEX 10

Carbon and rubber outsole. Full carbon sole, high stiffness and lightness tuned for power transfer and excellent traction when on foot.

Intended use: XC, CX, Gravel.

### STEIFIGKEITSINDEX 10

Außensohle aus Carbon und Gummi. Vollcarbonsohle, hohe Steifigkeit und geringes Gewicht, abgestimmt auf Kraftübertragung und hervorragende Traktion beim Gehen.

Verwendungszweck: XC, CX, Gravel.

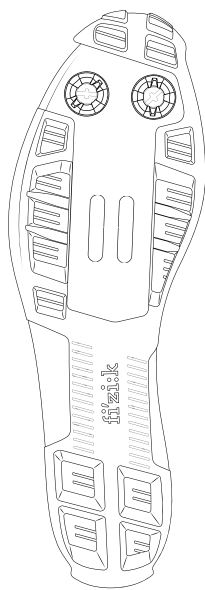

## X3

### INDICE DI RIGIDITÀ 8

Fiber composite for high stiffness and efficient power transfer with rubber outsole for comfort.

Intended use: XC, CX, Gravel.

### INDICE DE RIGIDITÉ 8

Faserkomposit für hohe Steifigkeit und effizienten Krafttransfer mit Gummi- sohle für Komfort.

Verwendungszweck: XC, CX, Gravel.

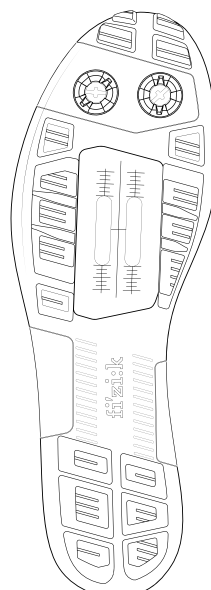

## X5

### STIFFNESS INDEX 5

Nylon and rubber outsole. Delivers pedalling efficiency alongside confident and secure off-road traction.

Intended use: XC, CX, Gravel.

### STEIFIGKEITSINDEX 5

Außensohle aus Nylon und Gummi. Sorgt für effizientes Pedalieren und sichere Traktion im Gelände.

Verwendungszweck: XC, CX, Gravel.

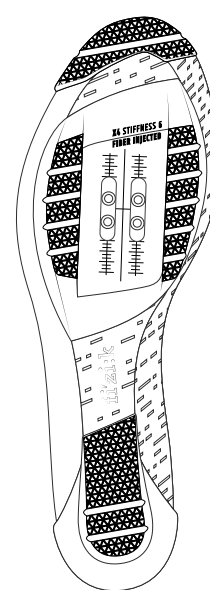

## X4

### STIFFNESS INDEX 6

Targeted stiffness and rubber tread for mixed surfaces.

Intended use: XC, CX, Gravel.

### STEIFIGKEITSINDEX 6

Gezielte Steifigkeit und gummierte Lauffläche für gemischte Oberflächen.

Verwendungszweck: XC, CX, Gravel.

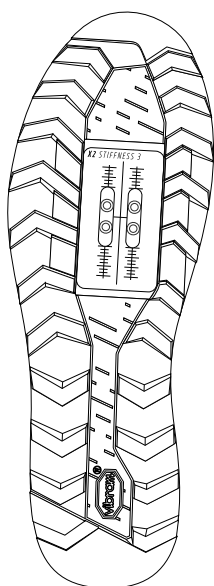

## X2

### STIFFNESS INDEX 3

Vibram® grip for traction, on and off the bike.

Intended use: All-Mountain, Gravel, Bikepacking.

### STEIFIGKEITSINDEX 3

Vibram®-Grip für Traktion, auf und neben dem Rad.

Verwendungszweck: All-Mountain, Gravel, Bikepacking.

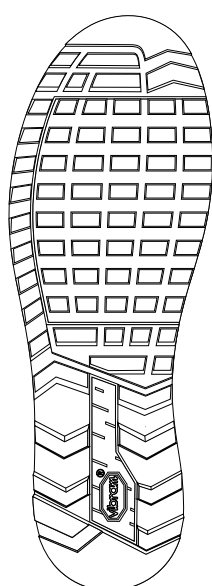

## X2 FLAT

### STIFFNESS INDEX 2

Vibram® Megagrip compound combined with fizik tread design ensures grip on flat pedals and traction off the bike.

Intended use: All-Mountain, Gravel, Bikepacking.

### STEIFIGKEITSINDEX 2

Die Vibram® Megagrip-Mischung in Kombination mit dem Fizik-Profil-Design sorgt für optimalen Halt auf Flat-Pedalen und Traktion abseits des Rades.

Verwendungszweck: All-Mountain, Gravel, Bikepacking.

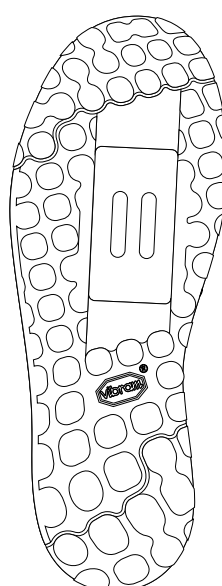

## X6

### STIFFNESS INDEX 5

Vibram® XS Trek EVO compound and lug pattern are engineered for pedal grip and bike control for fast and aggressive gravity riding.

Featuring an extended cleat track, the clip-in version enables you to run your cleats further back to allow for dropped heels on descents, improving both stability and control.

Intended use: DH-Enduro.

### STEIFIGKEITSINDEX 5

Die Vibram® XS Trek EVO-Mischung und das Stollenprofil sind auf Pedalhalt und Bike-Kontrolle für schnelles und aggressives Gravity-Riding ausgelegt.

Die Clip-in-Version verfügt über eine verlängerte Cleat-Spur, die es ermöglicht, die Cleats weiter hinten zu platzieren, um die Fersen bei Abfahrten zu senken und so Stabilität und Kontrolle zu verbessern.

Verwendungszweck: DH-Enduro.

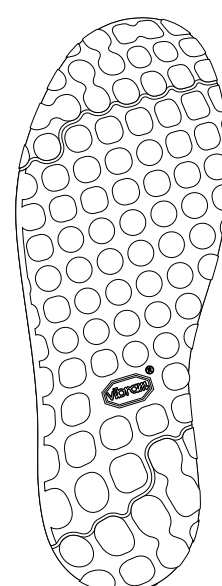

## X6 FLAT

### STIFFNESS INDEX 2

Vibram® Megagrip compound and lug pattern are engineered for pedal grip and bike control for fast and aggressive gravity riding.

Intended use: DH-Enduro.

### STEIFIGKEITSINDEX 2

Die Vibram® Megagrip-Mischung und das Stollenmuster wurden für den Grip auf dem Pedal und die Kontrolle über das Fahrrad bei schnellen und aggressiven Fahrten im Gelände entwickelt.

Verwendungszweck: DH-Enduro.

# ROAD AND TRIATHLON SHOES







VENTO INFINITO KNIT CARBON 2 is a performance road racing cycling shoe engineered with a new, advanced knitted upper for enhanced breathability.

VENTO INFINITO KNIT CARBON 2 ein Hochleistungs-Rennradschuh, mit einem neuartigen, innovativen Strick-Obermaterial für verbesserte Atmungsaktivität.

## VENTO INFINITO KNIT CARBON 2

Intended use: ROAD RACING

Weight: 225g

**Infito:** Advanced volume control of the forefoot area  
**Volume Control:** Independent fit adjustment for instep and forefoot  
**Knitted Upper:** Extremely ventilated construction with supportive heat-fused TPU yarn  
**R2 Carbon Fiber Outsole:** Optimized cleat positioning, high stiffness and lightness tuned for power transfer

**Infito:** Verbesserte Volumenkontrolle des Vorfußbereichs  
**Volume Control:** Unabhängige Passformanpassung für den Fußrücken und den Vorfuß  
**Gestricktes Obermaterial:** Extrem gut belüftete Konstruktion mit stützendem, thermofixiertem TPU-Garn  
**R2 Carbon-Außensohle:** Optimierte Positionierung der Cleats, hohe Steifigkeit und Leichtigkeit abgestimmt auf eine optimale Kraftübertragung



ARTICLE	EAN	MODEL	COLOR	SIZE	OUTSOLE	CLOSURE	UPPER	SRP (€)
VER2IKR1C1010	Various	<b>Vento Infito Knit</b>	Black/Black	36-48*	Full Carbon	2x BOA Li2 B dials	Knitted	380
VER2IKR1C9610	Various	<b>Carbon 2</b>	Coral/Black		Unidirectional			380

All models are available in full sizes | Alle Modelle sind in ganzen Größen erhältlich

(\*) Also available in sizes: **42½, 43½, 44½** | Auch in den folgenden Größen erhältlich: **42½, 43½, 44½**



VENTO INFINITO CARBON 2 is the latest refinement of our legendary performance road racing cycling shoe, developed with and chosen by leading athletes throughout the pro peloton.

VENTO INFINITO CARBON 2 die neuste Version unseres legendären Rennradschuhs, entwickelt mit und getragen von Top-Athleten aus dem Profi-Peloton.

## VENTO INFINITO CARBON 2

Intended use: ROAD RACING

Weight: 227g

**Infinito:** Advanced volume control of the forefoot area  
**Volume Control:** Independent fit adjustment for instep and forefoot  
**Microtex Upper:** Supple yet strong and durable for a comfortable and consistent fit  
**R2 Carbon Fiber Outsole:** Optimized cleat positioning, high stiffness and lightness tuned for power transfer

**Infinito:** Verbesserte Volumenkontrolle des Vorfußbereichs  
**Volume Control:** Unabhängige Passformanpassung für den Fußrücken und den Vorfuß  
**Microtex Obermaterial:** geschmeidig und dennoch robust und strapazierfähig für eine bequeme und beständige Passform  
**R2 Carbon-Außensohle:** Optimierte Positionierung der Cleats, hohe Steifigkeit und Leichtigkeit abgestimmt auf eine optimale Kraftübertragung



ARTICLE	EAN	MODEL	COLOR	SIZE	OUTSOLE	CLOSURE	UPPER	SRP (€)
VER2IXR1C1010	Various	<b>Vento Infinito Carbon 2</b>	Black/Black	36-48*	Full Carbon Unidirectional	2x BOA Li2 B dials	Microtex	380
VER2IXR1C2010	Various		White/Black					380
VER2IXR1C7096	Various		Grey/Coral**					380

All models are available in full sizes | Alle Modelle sind in ganzen Größen erhältlich

(\*) Also available in sizes: **42½, 43½, 44½** | Auch in den folgenden Größen erhältlich: **42½, 43½, 44½**

(\*\*) Until sold out | Solange der Vorrat reicht



VENTO POWERSTRAP AEROWEAVE. The innovative, second-generation Aeroweave upper makes Powerstrap Aeroweave a straight-up racing shoe. The lightest and most breathable in the range, built with a high tenacity net-like structure coupled with our stiffest carbon outsole.

VENTO POWERSTRAP AEROWEAVE. Das innovative Obermaterial aus der zweiten Generation Aeroweave macht den Powerstrap Aeroweave zu einem reinrassigen Rennschuh. Der leichteste und atmungsaktivste in der Serie, mit einer Netzstruktur von hoher Reißfestigkeit in Kombination mit unserer steifsten Carbonsohle.

## VENTO POWERSTRAP AEROWEAVE CARBON

Intended use: ROAD RACING

Weight: 184g

Aeroweave: extremely breathable, high tenacity netlike structure

Powerstrap: foot-wrapping Velcro closure designed for an enveloping fit

R3 carbon outsole: optimized cleat positioning, ultimate stiffness and lightness tuned for maximum power transfer

Aeroweave: extrem atmungsaktive, netzartige Struktur mit hoher Reißfestigkeit

Powerstrap: Fuß-umschließender Klettverschluss für eine passgenaue Passform R3

Carbonsohle: optimierte Cleat-Positionierung, ultimative Steifigkeit und Leichtigkeit für maximalen Krafttransfer



ARTICLE	EAN	NEW	MODEL	COLOR	SIZE	OUTSOLE	CLOSURE	UPPER	SRP (€)
VER3PAR1C2020	Various	<b>NEW</b>	<b>Vento Powerstrap</b>	White/White	36-48*	Full Carbon	Powerstrap	Aeroweave	350
VER3PAR1C9631	Various	<b>NEW</b>	<b>Aeroweave Carbon</b>	Coral/Orange	36-48*				

All models are available in full sizes | Alle Modelle sind in ganzen Größen erhältlich

(\*) Also available in sizes: **42½, 43½, 44½** | Auch in den folgenden Größen erhältlich: **42½, 43½, 44½**



TEMPO DECOS CARBON is designed to exist at the nexus of comfort and performance, an essential shoe combining a minimalistic single BOA upper with a stiff carbon sole to go the distance.

Der TEMPO DECOS CARBON wurde entwickelt, um die Schnittstelle zwischen Komfort und Performance zu bilden. Er verfügt über ein minimalistisches, einfaches BOA-Verschlussystem in Verbindung mit einer steifen Carbon Sohle, um jede Strecke zu meistern.

## TEMPO DECOS CARBON

Intended use: ROAD RACING

Weight: 205g

PU Laminated Mesh Upper: Enhanced ventilation with support where its needed most

R2 Carbon Fibre Outsole: Optimised cleat positioning, lightweight, stiff and fine-tuned for power transfer

PU-laminiertes Mesh-Obermaterial: verbesserte Belüftung mit Unterstützung, wo sie am meisten gebraucht wird

R2 Carbonfaser-Außensohle: Optimierte Positionierung der Cleats, leicht, steif und optimal auf Kraftübertragung abgestimmt



## TEMPO DECOS CARBON WIDE

Wide fit: Provides more fore-foot room with a higher volume ball and a wider metatarsal

Wide fit: Bietet mehr Platz im Vorfußbereich mit einem voluminöseren Ballen und einem breiteren Mittelfußbereich



ARTICLE	EAN	MODEL	COLOR	SIZE	OUTSOLE	CLOSURE	UPPER	SRP (€)
TPR2BMR1C3610	Various		Aubergine					290
TPR2BMR1C1010	Various	<b>Tempo Decos Carbon</b>	Black/Black	36-48*	Full Carbon Unidirectional	Li2 BOA® Fit System	PU Laminate Over Mesh	290
TPR2BMR1C2020	Various		White/White					290
TPR2BMR1C9910	Various		Iridescent Blue					290
TPR2BMW1C2020	Various	<b>Tempo Decos Wide</b>	White/White	36-48*	Full Carbon Unidirectional	Li2 BOA® Fit System	PU Laminate Over Mesh	290

All models are available in full sizes | Alle Modelle sind in ganzen Größen erhältlich

(\*) Also available in sizes: **42½, 43½, 44½** | Auch in den folgenden Größen erhältlich: **42½, 43½, 44½**







VENTO OMNA is a responsive, pure road cycling shoe developed for competitive riders seeking race-ready features and performance.

Der VENTO OMNA ist ein reaktionsfreudiger, kompromissloser Rennradschuh, der für Leistungssportler entwickelt wurde, die wettkampftaugliche Eigenschaften und Performance verlangen.

## VENTO OMNA

Intended use: ROAD

Weight: 238g

R5 nylon outsole: Optimized cleat positioning with a moderate stiffness index

PU upper: A resilient, yet lightweight exterior that makes the shoe comfortable while retaining durability

Ready to race: Performance fit, tunable with a bi-directional single BOA® dial

R5-Nylon-Außensohle: optimierte Positionierung der Cleats mit einem moderaten Steifigkeitsindex

PU-Obermaterial: ein widerstandsfähiges, aber leichtes Obermaterial, das den Schuh bequem und gleichzeitig langlebig macht

Bereit für den Renneinsatz: Performance-Passform, einstellbar mit einem bidirektionalen BOA®-Einstellrad



## VENTO OMNA WIDE NEW

Wide fit: Provides more fore-foot room with a higher volume ball and a wider metatarsal

Wide fit: Bietet mehr Platz im Vorfußbereich mit einem voluminöseren Ballen und einem breiteren Mittelfußbereich



ARTICLE	EAN	NEW	MODEL	COLOR	SIZE	OUTSOLE	CLOSURE	UPPER	SRP (€)
VER5BPR1K1010	Various			Black/Black	36-48*				165
VER5BPR1K2010	Various			White/Black	36-48				165
VER5BPR1K3010	Various		<b>Vento Omna</b>	Red/Black	36-48	R5 nylon	1x BOA Li2 Dial C Fit System	PU	165
VER5BPR1K7510	Various			Metallic Gun Metal/Black	36-48				165
VER5BPR1K3A10	Various			Cherry/Black	36-48				165
VER5BPW1K2010	Various	<b>NEW</b>	<b>Vento Omna Wide</b>	White/Black	36-48	R5 nylon	1x BOA Li2 Dial C Fit System	PU	165

All models are available in full sizes | Alle Modelle sind in ganzen Größen erhältlich

(\*) Also available in sizes: **42½, 43½, 44½** | Auch in den folgenden Größen erhältlich: **42½, 43½, 44½**



TEMPO OVERCURVE R4 all-round road cycling shoe is designed to be equally at home on weekend group rides, in daily training, and stretching out on a granfondo.

TEMPO OVERCURVE R4 Allround-Straßenradschuh ist so konzipiert, dass er bei Gruppenfahrten am Wochenende, beim täglichen Training und bei ausgedehnten Granfondos gleichermaßen zu Hause ist.

## TEMPO OVERCURVE R4

Intended use: ROAD

Weight: 230g

Overcurve: asymmetrical construction that ergonomically conforms to the foot's anatomy  
 PU laminated mesh upper: enhanced ventilation with support where needed  
 R4 carbon injected outsole: moderately stiff for efficient power transfer in comfort

Overcurve: asymmetrische Konstruktion, die sich ergonomisch an die Anatomie des Fußes anpasst  
 Obermaterial aus PU-laminiertem Mesh: verbesserte Belüftung mit Unterstützung, wo sie benötigt wird  
 R4 Laufsohle mit eingespritzter Carbonfaser: mäßig steif für eine effiziente und komfortable Kraftübertragung



## TEMPO OVERCURVE R4 WIDE

Wide fit: Provides more fore-foot room with a higher volume ball and a wider metatarsal

Wide fit: Bietet mehr Platz im Vorfußbereich mit einem voluminöseren Ballen und einem breiteren Mittelfußbereich



ARTICLE	EAN	MODEL	COLOR	SIZE	OUTSOLE	CLOSURE	UPPER	SRP (€)
TPR4OXR1K1010	Various	<b>Tempo Overcurve R4</b>	Black/Black	36-48	Carbon Injected Nylon	1x BOA IP1-B dial	Pu Laminated Mesh	219
TPR4OXR1K2010	Various		White/Black					219
TPR4OXR1K4210	Various		Navy/Black					219
TPR4OIR1K8310	Various		Copper/Black Iridescent					219
TPR4OIR1K8410	Various		Beetle/Black Iridescent					219
TPR4OXW1K1010	Various	<b>Tempo Overcurve R4 Wide</b>	Black/Black	36-48	Carbon Injected Nylon	1x BOA IP1-B dial	Pu Laminated Mesh	219



TEMPO OVERCURVE R5 is quick-fit road cycling shoe to suit every rider and every ride.

TEMPO OVERCURVE R5 ist ein quick-fit Straßenradschuh für jeden Fahrer und jede Fahrt geeignet.

## TEMPO OVERCURVE R5

Intended use: ROAD

Weight: 246g

Overcurve: asymmetrical construction that ergonomically conforms to the foot's anatomy  
 Microtex upper: supple yet strong and durable for a comfortable and consistent fit  
 R5 nylon composite outsole: delivers balance between comfort and pedalling efficiency

Overcurve: asymmetrische Konstruktion, die sich ergonomisch an die Anatomie des Fußes anpasst  
 Obermaterial aus Microtex: robustes und haltbares Obermaterial für eine bequeme und beständige Passform

R5 Nylon-Verbund-Laufsohle: bietet ein ausgewogenes Verhältnis zwischen Komfort und Pedaleffizienz



ARTICLE	EAN	MODEL	COLOR	SIZE	OUTSOLE	CLOSURE	UPPER	SRP (€)
TPR50CMI21010	Various	<b>Tempo Overcurve R5</b>	Black/Black**	36-48*	Carbon Reinforced Nylon	1x BOA IP1-B dial + front Velcro	Microtex	119
TPR50CMI22010	Various		White/Black**	36-48				119
TPR50CMI21092	Various		Black/Pink Fluo**	36-42				119
TPR50CMI21090	Various		Black/Yellow Fluo**	38-48				119
TPR50CMI27510	Various		Metallic Gun Metal/Black**	36-48				119

All models are available in full sizes | Alle Modelle sind in ganzen Größen erhältlich

(\*) Also available in sizes: **42½, 43½, 44½** | Auch in den folgenden Größen erhältlich: **42½, 43½, 44½**

(\*\*) Until sold out | Solange der Vorrat reicht



TEMPO POWERSTRAP R5 is a versatile road cycling shoe with an innovative Velcro closure designed for an enveloping fit.

TEMPO POWERSTRAP R5 ist ein vielseitiger Straßenradschuh mit einem innovativen Klettverschluss, der speziell für eine umhüllende Passform entwickelt wurde.

## TEMPO POWERSTRAP R5

Intended use: ROAD

Weight: 255g

Powerstrap: foot-wrapping Velcro closure designed for an enveloping fit

R5 nylon composite outsole: delivers balance between comfort and pedalling efficiency

Powerstrap: fußumschließender Klettverschluss für einen umfassenden Sitz

R5 Nylon-Verbund-Laufsohle: sorgt für Ausgewogenheit zwischen Komfort und Effizienz beim Treten



ARTICLE	EAN	MODEL	COLOR	SIZE	OUTSOLE	CLOSURE	UPPER	SRP (€)
TPR5PSPU21010	Various	<b>Tempo Powerstrap R5</b>	Black/Black	36-48	Carbon Reinforced Nylon	Foot-wrapping Velcro	PU	139
TPR5PSPU22010	Various		White/Black					139
TPR5PSRE17410	Various		Reflective Grey/Black					149



TEMPO ARTICA R5 GTX is our road-specific winter shoe, insulated with a fleeced lining for extra warmth, breathable and waterproof thanks to an advanced GORE-TEX membrane.

TEMPO ARTICA R5 GTX ist unser straßenspezifischer Winterschuh, isoliert mit einem Fleece-Futter für zusätzliche Wärme, atmungsaktiv und wasserdicht dank einer fortschrittlichen GORE-TEX Membran.

## TEMPO ARTICA R5 GTX

Intended use: ROAD

Weight: 319g

**Gore-Tex Koala membrane:** Insulated, waterproof and breathable, the Koala membrane by GORE-TEX, keeps you warm and dry during harsh winter riding conditions  
**Fleeced lining:** Soft brushed-fleece lining adds insulation and comfort on the coldest winter rides  
**All-day comfort:** Generous fit and easy adjustments provided by a practical single-dial BOA® fit system and secure Velcro cuff strap

**Gore-Tex Koala-Membran:** Die isolierende, wasserdichte und atmungsaktive Koala-Membran von GORE-TEX hält Sie bei rauen Winterbedingungen warm und trocken  
**Flauschiges Futter:** weiches, gebürstetes Fleece-Futter sorgt für Isolierung und Komfort auf den kältesten Wintertouren  
**Ganztägiger Komfort:** großzügige Passform und einfache Anpassung durch ein praktisches BOA®-Fit-System mit einem Einstellrad und einen sicheren Klettverschluss am Beinabschluss



ARTICLE	EAN	MODEL	COLOR	SIZE	OUTSOLE	CLOSURE	UPPER	SRP (€)
TPR5AGR1V1010	Various	<b>Tempo Artica R5 GTX</b>	Black/Black	40-48	R5 nylon	1x BOA L6 dial & ankle Velcro strap	High-density PU upper + Ripstop fabric	259
TPR5AGR1V2070	Various		White/Grey					259



TRANSIRO HYDRA AEROWEAVE is a pure triathlon racing shoe that combines an innovative second-generation Aeroweave upper with a stiff carbon outsole for efficient pedaling and faster, worry-free transitions.

Der TRANSIRO HYDRA AEROWEAVE ist ein echter Triathlon-Rennschuh, bei dem ein innovatives Aeroweave-Obermaterial der zweiten Generation mit einer steifen Carbon-Außensohle für effizientes Pedalieren und schnellere Übergänge kombiniert wurde.

## TRANSIRO HYDRA AEROWEAVE CARBON

Intended use: TRIATHLON

Weight: 225g

Aeroweave: extremely breathable, high tenacity net-like structure  
 Instep velcro strap for fast transition  
 R2 outsole: full carbon, stiffness index 10

Aeroweave: extrem atmungsaktive, hochfeste netzartige Struktur  
 Klettverschluss am Rist für schnelleren Übergang  
 R2-Außensohle: Vollcarbon, Steifigkeitsindex 10



ARTICLE	EAN	MODEL	COLOR	SIZE	OUTSOLE	CLOSURE	UPPER	SRP (€)
TRR2PAR1K2080	Various	<b>Transiro Hydra Aeroweave Carbon</b>	White/Silver	36-48*	Full carbon unidirectional	Instep velcro strap	Aeroweave	290
TRR2PAR1K20RB	Various		White/Red-Blue					290

All models are available in full sizes | Alle Modelle sind in ganzen Größen erhältlich

(\*) Also available in sizes: **42½, 43½, 44½** | Auch in den folgenden Größen erhältlich: **42½, 43½, 44½**



TRANSIRO HYDRA is a triathlon shoe designed to facilitate easier transitions, built with a breathable upper and moderately stiff nylon outsole that combines comfort and pedaling efficiency.

Der TRANSIRO HYDRA ist ein Triathlon-Schuh, der für leichtere Übergänge entwickelt wurde, bestehend aus einem atmungsaktiven Obermaterial und einer mäßig steifen Nylon-Außensohle, welche Komfort und Pedalier-effizienz vereint.

## TRANSIRO HYDRA

Intended use: TRIATHLON

Weight: 233g

3D Air mesh: extremely breathable and light upper  
Instep velcro strap for fast transition  
New R5 nylon outsole - stiffness index 6

3D Air Mesh: extrem atmungsaktives und leichtes Obermaterial  
Klettverschluss auf dem Spann für einen schnellen Übergang  
Neue R5-Nylon-Außensohle - Steifigkeitsindex 6



ARTICLE	EAN	MODEL	COLOR	SIZE	OUTSOLE	CLOSURE	UPPER	SRP (€)
TRR5PMR1K2010	Various	<b>Transiro Hydra</b>	White/Black	36-48	R5 nylon	Instep velcro strap	3D Air mesh	149
TRR5PMR1K20MR	Various		White/Metallic Red					149
TRR5PMR1K20MB	Various		White/Metallic Blue					149



# OFF-ROAD SHOES







VENTO FEROX is a shoe designed for off-road racing, xc and gravel, combining a performance ready carbon outsole with a breathable and lightweight, yet durable and resistant, upper construction.

VENTO FEROX ist ein Schuh, der für Off-Road-Rennen, XC und Gravel entwickelt wurde. Er kombiniert eine leistungsfähige Carbon-Außensohle mit einer atmungsaktiven und leichten, aber dennoch haltbaren und widerstandsfähigen Schuhoberseite.

## VENTO FEROX CARBON

Intended use: CROSS-COUNTRY / GRAVEL RACING

Weight: 300g

PU Laminated Mesh Upper: light and breathable in a tear-proof construction

Powerstrap & Boa Fit System: dual closure system where the instep and the mid foot are separately adjustable for a customized and secure fit

X1 Carbon & Rubber Outsole: Full carbon sole, high stiffness and lightness tuned for power transfer and excellent traction when on foot

PU-laminiertes Mesh-Obermaterial: leicht und atmungsaktiv mit reißfester Konstruktion

Powerstrap & Boa Fit System: doppeltes Verschlussystem, bei dem der Rist und der Mittelfuß separat verstellbar sind, für eine individuelle und sichere Passform

X1 Carbon & Gummi-Außensohle: Vollcarbon-Sohle, hohe Steifigkeit und Leichtigkeit, abgestimmt auf Kraftübertragung und hervorragende Traktion beim Gehen



ARTICLE	EAN	MODEL	COLOR	SIZE	OUTSOLE	CLOSURE	UPPER	SRP (€)
VEX1WMR1C1010	Various	<b>Vento</b>	Black/Black	36-48	Full Carbon Unidirectional, Rubber Treads	Li2 BOA® Fit System + Velcro Strap	PU Laminated Mesh	299
VEX1WMR1C3820	Various	<b>Ferox</b>	Lilac/White					299



VENTO PROXY is an off-road racing cycling shoe developed for competitive riders seeking race-ready features and efficient power transfer on unpaved roads.

Der VENTO PROXY ist ein Off-Road-Radschuh, der für Leistungssportler entwickelt wurde, die renntaugliche Eigenschaften und eine effiziente Kraftübertragung auf unbefestigten Straßen suchen.

**VENTO**  
**PROXY** NEW

Intended use: XC, CX, GRAVEL

Weight: 325g

PU laminated mesh upper: light and breathable in a tear-proof construction  
 Practical single-BOA closure system  
 X3 Fiber composite and rubber outsole: high stiffness for efficient power transfer in comfort

PU-laminiertes Mesh-Obermaterial: leicht und atmungsaktiv in einer reißfesten Konstruktion  
 Praktisches Einzel-BOA-Schnürsystem  
 X3 Faserkomposit- und Gummisohle: hohe Steifigkeit für effizienten Krafttransfer mit Komfort



ARTICLE	EAN	NEW	MODEL	COLOR	SIZE	OUTSOLE	CLOSURE	UPPER	SRP (€)
VEX3BPR1V1010	Various	<b>NEW</b>		Black/Black	36-48*				229
VEX3BPR1V9635	Various	<b>NEW</b>	<b>Vento Proxy</b>	Coral/Purple	36-48*	X3 Fiber composite and rubber outsole	BOA Li2	PU Laminated Mesh	229
VEX3BPR1V2020	Various	<b>NEW</b>		White/White	36-48*				229

All models are available in full sizes | Alle Modelle sind in ganzen Größen erhältlich

(\*) Also available in sizes: **42½, 43½, 44½** | Auch in den folgenden Größen erhältlich: **42½, 43½, 44½**



TERRA ATLAS is our versatile and reliable all-rounder, for all-terrain gravel, mountain biking and beyond.

TERRA ATLAS Unser vielseitiger und zuverlässiger Allrounder, für All-Terrain Gravel Fahrten, Mountainbiking und allem darüber hinaus.

## TERRA ATLAS

Intended use: CROSS-COUNTRY / GRAVEL /  
DOWN-COUNTRY

Weight: 355g

The All-Terrain, All-Rounder: suits a wide range of riding styles, from all-mountain to crosscountry and gravel  
All-Day Comfort: generous fit, with a practical single-BOA closure system  
X5 Nylon & Rubber Outsole: delivers pedalling efficiency alongside confident and secure off-road traction

Der All-Terrain-Allrounder: Geeignet für eine große Bandbreite an Fahrstilen, von All-Mountain über Crosscountry bis hin zu Gravel  
All-Day Comfort: Großzügige Passform mit praktischem Single-BOA-Verschlussystem  
X5 Nylon & Gummi-Außensohle: sorgt für effizientes Pedalieren und sichere Traktion im Gelände



LIMITED EDITION

LIMITED EDITION



ARTICLE	EAN	MODEL	COLOR	SIZE	OUTSOLE	CLOSURE	UPPER	SRP (€)
TEX5BPR1K7010	Various		Grey/Black					159
TEX5BPR1K1010	Various		Black/Black					159
TEX5BPR1K6110	Various	<b>Terra Atlas</b>	Army	36-48	Nylon, Rubber Treads	L6 BOA® Fit System	Tear Resistant High Density PU	159
TEX5BPR1K3710	Various		Pink Grape					159
TEX5BPR1K1033	Various		Black/Splash Purple					159
TEX5BPR1K5039	Various		Green/Splash Pink					159



VENTO OVERCURVE X3 is an XC racing shoe designed and created to deliver its core functions: to fit precisely, protect you and transfer watts efficiently as you power through the race tape.

VENTO OVERCURVE X3 ist ein XC-Rennschuh, der entwickelt und hergestellt wurde, um die wesentlichen Funktionen zu erfüllen: präzise Passform, optimaler Schutz und effiziente Watt-Übertragung während des Rennens.

## VENTO OVERCURVE X3

Intended use: CROSS-COUNTRY

Weight: 299g

Overcurve: asymmetrical construction that ergonomically conforms to the foot's anatomy  
 Microtex upper: supple yet strong and durable for a comfortable and consistent fit  
 X3 outsole: a carbon injected race-stiff interface with a durable TPU tread

Overcurve: asymmetrische Konstruktion, die sich ergonomisch an die Anatomie des Fußes anpasst  
 Obermaterial aus Microtex: geschmeidig und dennoch stabil und strapazierfähig für eine komfortable und beständige Passform  
 X3-Außensohle: eine renntaugliche Verbindung aus eingespritztem Carbon mit einer langlebigen TPU-Lauffläche



ARTICLE	EAN	MODEL	COLOR	SIZE	OUTSOLE	CLOSURE	UPPER	SRP (€)
VEX3OCMI11010	Various	<b>Vento</b>	Black/Black**	36-48*	Carbon Injected Nylon, TPU Studs	1x BOA IP1-B dial	Microtex	229
VEX3OCMI12010	Various	<b>Overcurve X3</b>	White/Black**					229

All models are available in full sizes | Alle Modelle sind in ganzen Größen erhältlich

(\*) Also available in sizes: **42½, 43½, 44½** | Auch in den folgenden Größen erhältlich: **42½, 43½, 44½**

(\*\*) Until sold out | Solange der Vorrat reicht





TERRA POWERSTRAP X4 is a versatile and ubiquitous gravel-focused shoe, designed for drop-bar riders whose adventures and aspirations take them beyond the traditional paved roads.

TERRA POWERSTRAP X4 ist ein vielseitiger und vielseitiger Schuh mit Schwerpunkt auf Gravel Fahrten. Entwickelt für Fahrer, deren Abenteuer und Ambitionen über die traditionellen asphaltierten Straßen hinausgehen.

**TERRA**  
**POWERSTRAP X4**

Intended use: GRAVEL

Weight: 292g

Powerstrap: foot-wrapping Velcro closure designed for an enveloping fit  
X4 outsole: targeted stiffness and rubber tread for mixed surfaces

Powerstrap: fußumschließender Klettverschluss für einen umfassenden Sitz  
X4-Außensohle: gezielte Steifigkeit und Gummilauffläche für gemischte Böden



ARTICLE	EAN	MODEL	COLOR	SIZE	OUTSOLE	CLOSURE	UPPER	SRP (€)
TEX4PPR1K8586	Various	<b>Terra</b>	Mud/Caramel	36-48	Fiber Reinforced Nylon, Rubber Tread	Foot-wrapping Velcro	PU	159
TEX4PPR1K1010	Various	<b>Powerstrap X4</b>	Black/Black					159





TERRA CLIMA X2 is a weatherproof and breathable all-mountain shoe that won't back down when riding conditions turn less favourable.

TERRA CLIMA X2 ist ein wetterfester und atmungsaktiver All-Mountain-Schuh, der auch bei unfreundlicheren Fahrbedingungen nicht nachgibt.

## TERRA CLIMA X2

Intended use: ALL-MOUNTAIN

Weight: 414g

Clima: weatherproof/breathable upper  
 Ripstop fabric: woven fabric resistant to tearing and ripping  
 Integrated knitted gaiter: seals out debris  
 X2 outsole: Vibram grip for traction, on and off the bike

Clima: wetterfestes/atmungsaktives Obermaterial  
 Ripstop-Gewebe: ein reiß- und abriebfestes Gewebe  
 Integrierte gestrickte Gamasche: hält Schmutz fern  
 X2 Laufsohle: Vibram-Grip für Traktion, auf und neben dem Rad



ARTICLE	EAN	MODEL	COLOR	SIZE	OUTSOLE	CLOSURE	UPPER	SRP (€)
TEX2CLTX11010	Various	<b>Terra Clima X2</b>	Black/Black**	36-48	Nylon Shank, EVA Midsole, Vibram Megagrip Tread	Instep Velcro + 1x BOA L6 dial	Ripstop Fabric with Waterproof/Breathable Membrane	250

(\*\*) Until sold out | Solange der Vorrat reicht



TERRA ERGOLACE X2 is a rugged, adaptable, lace-up mountain biking shoe that's true to the roots of off-road riding: tackling every kind of terrain, happy going up and down hill, on and off the bike.

TERRA ERGOLACE X2 ist ein robuster, anpassungsfähiger Mountainbike-Schnürschuh, der den Grundprinzipien des Geländefahrens treu bleibt: jedes Gelände zu meistern, bergauf und bergab, auf und abseits des Fahrrads.

**TERRA**  
**ERGOLACE X2**

Intended use: TRAIL, GRAVEL, BIKE PACKING

Weight: 329g

Ergolace: ergonomic lace-up closure for an anatomical fit

Ripstop fabric: woven fabric resistant to tearing and ripping

X2 outsole: Vibram grip for traction, on and off the bike

Ergolace: ergonomischer Schnürverschluss für eine anatomische Passform

Ripstop-Gewebe: reiß- und reißfestes Gewebe

X2 Laufsohle: Vibram-Grip für Traktion, auf und neben dem Rad



Black/Black  
Available also in FLAT VERSION



FLAT VERSION Weight: 303g



ARTICLE	EAN	MODEL	COLOR	SIZE	OUTSOLE	CLOSURE	UPPER	SRP (€)
TEX2ETR1K4610	Various		Teal Blue/Black					129
TEX2ETR1K5886	Various	<b>Terra Ergolace X2</b>	Olive/Caramel	36-48	Nylon Shank, EVA Midsole, Vibram Tread	Laces	Ripstop Fabric	129
TEX2ETR1K1010	Various		Black/Black					129
TEX2ETF1K1010	Various	<b>Terra Ergolace X2 Flat</b>	Black/Black	36-48	EVA Midsole, Vibram Megagrip Tread	Laces	Ripstop Fabric	129



GRAVITA TENSOR is a solid, lightweight, form-fitting gravity mountain bike shoe that is ready to race.

GRAVITA TENSOR ist ein robuster, leichter, anpassungsfähiger Gravity-Mountainbike-Schuh, bereit für den Renneinsatz.

## GRAVITA TENSOR

Intended use: DH, ENDURO

Weight: 410g

Clip-in Gravita Outsole: Vibram Megagrip and lug pattern engineered for pedal grip and bike control  
 Tensor: precise fit and foot tensioning for performance  
 Injection moulded TPU armoured toe-box: solid foot protection for rowdy riding  
 Ripstop fabric: woven fabric resistant to tearing and ripping

Clip-in Gravita-Außensohle: Vibram Megagrip und Stollenmuster, entwickelt für Pedalhalt und Fahrradkontrolle  
 Tensor: präzise Passform und Fußabstützung für mehr Leistung  
 Spritzgussgeformte TPU-geschützte Zehenkappe:  
 solider Fußschutz für ruppiges Fahren  
 Ripstop-Gewebe: Gewebe, das reiß- und abriebfest ist



Available also in FLAT VERSION



FLAT VERSION Weight: 310g



ARTICLE	EAN	MODEL	COLOR	SIZE	OUTSOLE	CLOSURE	UPPER	SRP (€)
GRX6TTC1C1010	Various	<b>Gravita Tensor</b>	Black/Black	36-48	Nylon Shank, EVA Midsole, Vibram Xs Trek EVO Tread	Laces + Instep Velcro	Ripstop Fabric + TPU Reinforcements	179
GRX6TTF1C1010	Various	<b>Gravita Tensor Flat</b>	Black/Black	36-48	EVA Midsole, Vibram Megagrip Tread	Laces + Instep Velcro	Ripstop Fabric + TPU Reinforcements	179



GRAVITA VERSOR is a versatile, lightweight lace-up mountain biking shoe that is ideal for those using flat pedals when mixing up lift-assisted DH laps with trail riding.

GRAVITA VERSOR ist ein vielseitiger, leichtgewichtiger Mountainbike-Schnürschuh, der sich ideal für diejenigen eignet, die Flat Pedals verwenden, wenn sie Lift-unterstützte DH-Runden mit Trailfahren kombinieren.

## GRAVITA VERSOR

Intended use: DH, ENDURO

Weight: 355g

Clip-in Gravita Outsole: Vibram Megagrip and lug pattern engineered for pedal grip and bike control  
 Ergolace: ergonomic lace-up closure for an anatomical fit  
 Ripstop fabric: woven fabric resistant to tearing and ripping

Clip-in Gravita-Außensohle: Vibram Megagrip und Stollenmuster, entwickelt für optimalen Pedalhalt und Fahrradkontrolle  
 Ergolace: ergonomischer Schnürverschluss für eine anatomische Passform  
 Ripstop-Gewebe: reiß- und abriebfestes Gewebe



Available also in FLAT VERSION



FLAT VERSION Weight: 270g



ARTICLE	EAN	MODEL	COLOR	SIZE	OUTSOLE	CLOSURE	UPPER	SRP (€)
GRX6VTC1K7085	Various	<b>Gravita Versor</b>	Grey/Mud	36-48	Nylon Shank, EVA Midsole, Vibram Xs Trek EVO Tread	Laces	Ripstop Fabric	139
GRX6VTF1K7085	Various	<b>Gravita Versor Flat</b>	Grey/Mud	36-48	EVA Midsole, Vibram Megagrip Tread	Laces	Ripstop Fabric	139



TERRA ERGOLACE GTX is designed to be adaptable, easily transitioning from gravel roads to singletrack and back again. The supportive fit makes it an ideal choice for extended adventures, where day-after-day comfort is key.

Der TERRA ERGOLACE GTX ist ein anpassungsfähiger Schuh, der sich leicht von Schotterstraßen auf Singletracks und wieder zurück bewegen lässt. Die stützende Passform macht ihn zur idealen Wahl für ausgedehnte Abenteuer, bei denen Komfort Tag für Tag entscheidend ist.

## TERRA

### ERGOLACE X2 GTX NEW

Intended use: TRAIL, GRAVEL, BIKEPACKING

Weight: 389g

Gore-tex prism 3l membrane: breathable triple-layered waterproof protection

Ready for every adventure: ideal choice for extended adventures where day-after-day comfort is key

Designed to be adaptable, easily transitioning from gravel roads to singletrack and back again

Ergolace: ergonomic lace-up closure for an anatomical fit

X2 outsole: vibram xs trek evo for traction, on and off the bike

Gore-Tex Prism 3L-Membran: atmungsaktiver, dreilagiger wasserdichter Schutz

Bereit für jedes Abenteuer: ideale Wahl für ausgedehnte Abenteuer, bei denen Tag für Tag Komfort im Vordergrund steht

Entwickelt, um sich anzupassen, problemlos von Schotterstraßen auf Singletracks und zurück

Ergolace: ergonomischer Schnürverschluss für eine anatomische Passform

X2-Außensohle: Vibram XS Trek Evo für Traktion auf und abseits des Fahrrads



ARTICLE	EAN	NEW	MODEL	COLOR	SIZE	OUTSOLE	CLOSURE	UPPER	SRP (€)
TEX2EGR1V1410	Various	<b>NEW</b>	<b>Terra Ergolace X2 GTX</b>	Ice Grey/Black	38-48	X2 outsole – nylon shank, EVA midsole and Vibram tread	Ergolace lace-up pattern	Ripstop fabric with GTX membrane	189
TEX2EGR1V1210	Various	<b>NEW</b>	<b>Terra Ergolace X2 GTX</b>	Anthracite/Black	38-49	X2 outsole – nylon shank, EVA midsole and Vibram tread	Ergolace lace-up pattern	Ripstop fabric with GTX membrane	189



TERRA ARTICA X5 GTX is our off-road winter cycling shoe. Both insulated and equipped with a breathable, waterproof GORE-TEX membrane, it is a versatile shoe that is reliable for all-terrain riding, gravel grinding, mountain biking and beyond.

Der TERRA ARTICA X5 GTX ist unser Offroad-Winterradschuh. Er ist sowohl wärmeisolierend als auch mit einer atmungsaktiven, wasserdichten GORE-TEX Membran ausgestattet und ist ein vielseitiger Schuh, der sich für jedes Gelände, Gravel Grinding, Mountainbiking und darüber hinaus eignet.

**TERRA**  
**ARTICA X5 GTX**

Intended use: GRAVEL, MTB

Weight: 432g

Artica: waterproof, breathable and insulated winter shoe

R5 nylon composite outsole: delivers balance between comfort and pedalling efficiency

Der Artica: ein wasserdichter, atmungsaktiver und isolierter Winterschuh

R5-Nylon-Verbundstoff-Laufsohle: Ausgewogenheit zwischen Komfort und effizienter Kraftübertragung



ARTICLE	EAN	MODEL	COLOR	SIZE	OUTSOLE	CLOSURE	UPPER	SRP (€)
TER5AGR1V1010	Various	<b>Terra Artica X5 GTX</b>	Black/Black	40-48	X5 nylon outsole with rubber treads	1x BOA L6 dial & ankle Velcro strap	High-density PU upper + Ripstop fabric	259
TER5AGR1V3510	Various		Purple/Black					259

# SOCKS

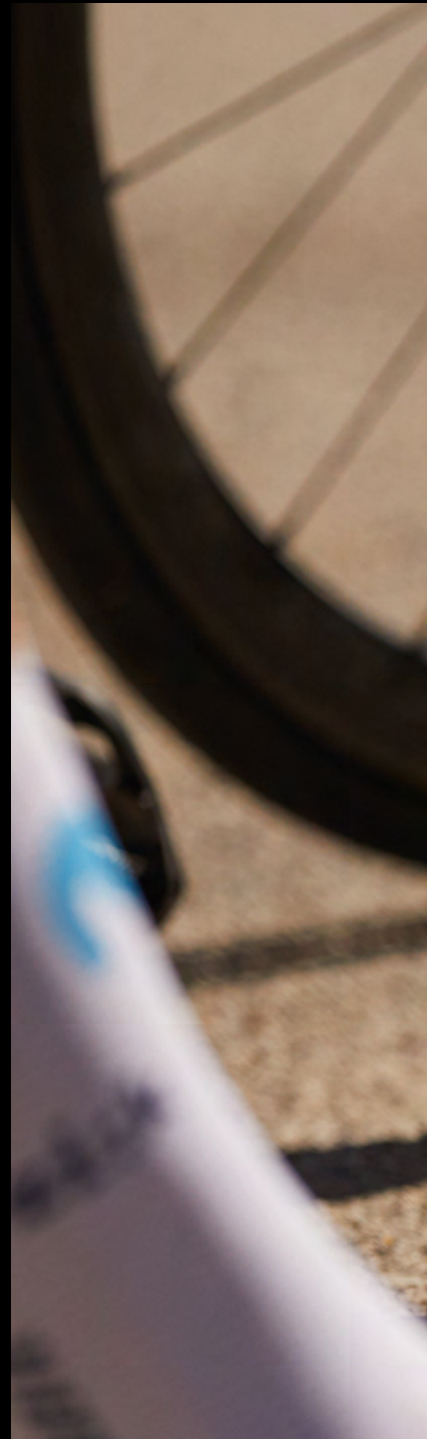





## PERFORMANCE CYCLING SOCKS NEW

Intended use: ROAD

Our performance road cycling socks, knit from anti-microbial Q-Skin® yarn for breathable, moisture-wicking comfort on every ride.

- QSkin yarn: highly wicking with antimicrobial properties
- Terry areas over the cleats: avoids pressure spots
- Thin and light construction to improve breathability

Unsere leistungsstarken Rennradsocken, gestrickt aus antimikrobieller Q-Skin®-Faser für atmungsaktiven, feuchtigkeitsableitenden Komfort auf jeder Fahrt.

- QSkin-Faser: hochfeuchtigkeitsableitend mit antimikrobiellen Eigenschaften
- Frottee-Bereiche über den Cleats: vermeidet Druckstellen
- Dünne und leichte Konstruktion zur Verbesserung der Atmungsaktivität



## TEAM EDITION CYCLING SOCKS NEW

Intended use: OFF-ROAD, ROAD RACING

Colorful, bold cycling socks designed to keep feet dry and spinning while repping team fizik in comfort and style.

- Techno PE yarn: highly wicking with antimicrobial properties
- Terry areas over the cleats and the instep: avoids pressure spots
- Thicker heel and toe box to improve comfort
- Ribs construction on leg

Farbenfrohe, auffällige Radsocken, die die Füße trocken halten und gleichzeitig das Team Fizik mit Komfort und Stil repräsentieren.

- Techno PE-Faser: hochfeuchtigkeitsableitend mit antimikrobiellen Eigenschaften
- Frottee-Bereiche über den Cleats und dem Rist: vermeidet Druckstellen
- Dickere Ferse und Zehenbox zur Verbesserung des Komforts
- Rippenkonstruktion am Bein



## OFF-ROAD CYCLING SOCKS NEW

Intended use: OFF-ROAD

Comfortable, resilient off-road cycling socks built to provide better breathability and lasting support on big adventures off the tarmac.

- Techno PE yarn: highly wicking with antimicrobial properties
- Terry areas over the cleats and the instep: avoids pressure spots
- Thicker heel and toe box to improve comfort
- Ribs construction on leg

Bequeme, strapazierfähige Offroad-Fahrradsocken, die eine bessere Atmungsaktivität und langanhaltende Unterstützung auf großen Abenteuern abseits des Asphalt bieten.

- Techno PE-Faser: hochfeuchtigkeitsableitend mit antimikrobiellen Eigenschaften
- Frottee-Bereiche über den Cleats und dem Rist: vermeidet Druckstellen
- Dickere Ferse und Zehenbox zur Verbesserung des Komforts
- Rippenkonstruktion am Bein



ARTICLE	EAN	NEW	MODEL	COLOR	SIZE	MATERIAL	SRP (€)
FZKSOCKSRO1000	Various	<b>NEW</b>	<b>Performance Cycling Socks</b>	Black	S (35-39) M (40-43) L (44-47)	QSkin yarn	18,90
FZKSOCKSRO2000	Various	<b>NEW</b>		White			18,90
FZKSOCKSTE382000	Various	<b>NEW</b>	<b>Team Edition Cycling Socks</b>	Lilac-White	S (35-39) M (40-43) L (44-47)	Techno PE yarn	18,90
FZKSOCKSOF7010	Various	<b>NEW</b>	<b>Off-Road Cycling Socks</b>	Grey-Black	S (35-39) M (40-43) L (44-47)	Techno PE yarn	18,90

## SHOES ACCESSORIES &amp; PARTS

ARTICLE	EAN	MODEL	COLOR	SIZE	DESCRIPTION	SRP (€)
<b>COVER</b>						
FZTCW1000	-	<b>Windproof Toe Cover</b>	Black	XS (36-40) M (41-44) XL (45-48)	PU Cloth Main Fabric, Microfiber Toe Cap & Puller, Bottom PU Reinforced	25
FZSCWP109400	-	<b>Waterproof Winter Overshoe</b>	Black/ Reflective	S (36-39) M (40-43) L (44-46) XL (47-48)	WP and Windproof Upper, Rubberized Bottom for Better Grip, Reflective logo and Piping	59
<b>KIT BOA SHOES</b>						
120026410	8058364168937	<b>LI2 Dial C KIT left and right</b>	Black	-	1 boa left + 1 boa right compatible with Vento Omnia	37,50
120025720	8058364161334	<b>LI2 Dial B KIT left and right</b>	White	-	1 boa left + 1 boa right compatible with Stabilita Carbon	37,50
120026210	8058364161327	<b>LI2 Dial B KIT left and right</b>	Black	-	1 boa left + 1 boa right compatible with new Vento Infinito Carbon, Vento Infinito Knit Carbon and Stabilita Carbon, Vento Ferox Carbon, Tempo Decos Carbon	37,50
120025620	8058364161310	<b>LI2 Dial A KIT left and right</b>	White	-	1 boa left + 1 boa right compatible with Tempo Decos Carbon	37,50
120026010	8058364161341	<b>IP1 KIT left and right</b>	Black	-	1 boa left + 1 boa right compatible with all fi'zi:k R1M-BC, INFINITO R1, ARIA R3, OVERCURVE R4, OVERCURVE R5, TRIATHLON TRANSIRO R1 and R3 shoes, M3B (model from ss 2017 to 2018), M4B (model 2018), INFINITO X1 and VENTO OVERCURVE X3	25
120025920	8058364161358	<b>IP1 KIT left and right</b>	White/ Transparent	-	1 boa left + 1 boa right compatible with all fi'zi:k R1M-BC, INFINITO R1, ARIA R3, OVERCURVE R4, OVERCURVE R5, TRIATHLON TRANSIRO R1 and R3 shoes, M3B (model from ss 2017 to 2018), M4B (model 2018), INFINITO X1 and VENTO OVERCURVE X3	25
120026110	8058364161365	<b>L6 KIT dial D left and right</b>	Black	-	1 boa left + 1 boa right compatible with all fi'zi:k M4B (model 2017), TERRA X5 (model 2018) and M6B (model from 2017 to current), TERRA CLIMA X2, TERRA ARTICA X2, Terra Artica GTX and Tempo Artica GTX	19
120025510	8058364161303	<b>LI2 Dial A KIT left and right</b>	Black	-	1 boa left + 1 boa right compatible with Vento Ferox Carbon and Tempo Decos Carbon	37,50
120026310	8058364161389	<b>L6 dial K KIT left and right / W CS1</b>	Black	-	1 boa left + 1 boa right compatible with all Terra Atlas shoes	19
120025820	8058364161372	<b>L6 KIT dial D left and right</b>	White	-	1 boa left + 1 boa right compatible with Tempo Artica GTX	19
<b>TOE STUDS KIT</b>						
KTOESTUD1010	8058364147420	<b>Toe Studs Kit</b>	Black	-	Toe Studs Kit - Vento Ferox Carbon & Terra Atlas (pair)	7,99
KTOESTUD5B5B	8058364149127		Mint	-	Toe Studs Kit - Vento Ferox Carbon (pair)	7,99
KTOESTUD9090	8058364149134		Yellow Fluo	-	Toe Studs Kit - Vento Ferox Carbon (pair)	7,99
<b>SHOES SPARE PARTS</b>						
FZHSPR1C1000	-	<b>Heel Skid Plate</b>		S-L	Heel Skid Plate (pair) R1B shoes	15
FZHSPR3C1000	-		Black	S-M-L	Heel Skid Plate (pair) R3B shoes	13
KHPVER21C1000	-			S-L	Heel Skid Plate Vento R2	15

# BARTAPES





# TOUCH



## TACKY

**2mm / 2.7mm / 3mm**

Finish that aids a sticky nonslip surface for ultimate grip in every condition.

Ein Finish, das zu einer klebrigen, rutschfesten Oberfläche für ultimativen Halt in jeder Situation beiträgt.



## CLASSIC

**2mm / 3mm**

A durable perforated leather-like texture, with traditional aesthetic and smooth surface slide easily to different riding positions.

Eine haltbare, perforierte, lederähnliche Textur mit traditioneller Ästhetik und glatter Oberfläche, die den Übergang zu verschiedenen Fahrpositionen erleichtert.



## SOFT

**3mm**

A matt-look, silky moisture absorbing surface.

Eine samtige, feuchtigkeitsabsorbierende Oberfläche mit einem matten Finish.

# CONSTRUCTION

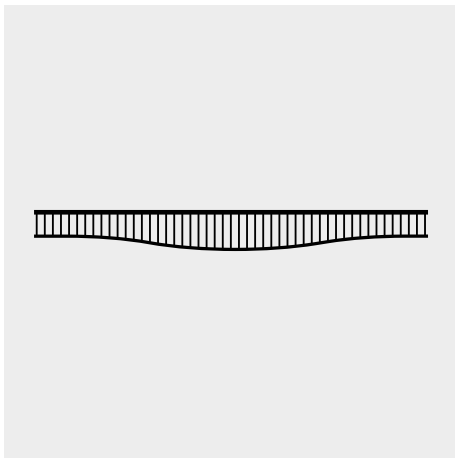

## MICROTEX

**2mm**

The thinnest option for pin Sharping handling and control.

Die dünnste Option für ultra präzises Handling und Kontrolle.

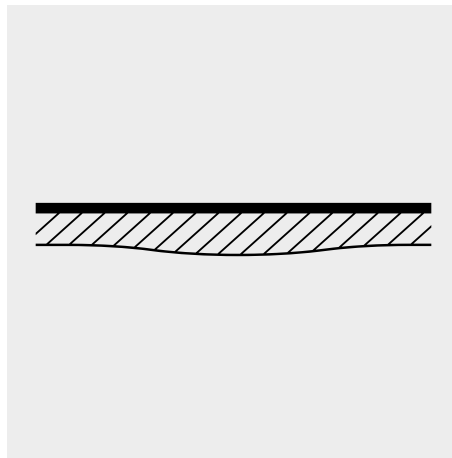

## SOLOCUSH

**2.7mm**

Our most streamlined cushioned construction, a single-layer chunky platform to rest on during longer rides without compromises on weight.

Unsere geradlinigste gepolsterte Konstruktion, eine einlagige, großvolumige Plattform, auf der man sich bei längeren Fahrten ohne Kompromisse beim Gewicht ausruhen kann.

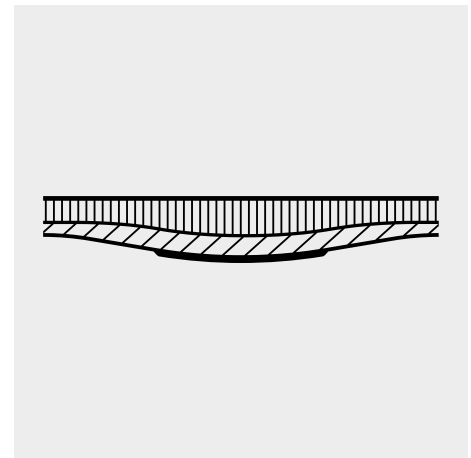

## BOND CUSH

**3mm**

A layered mid-padding polymer foam that aids the absorption of road buzz. Bonded to a microtex outer layer this material blend is our chunkiest option that combines comfort, versatility and durability.

Ein geschichteter Polymer-Schaumstoff mit mittlerer Polsterung, der Straßengeräusche abfängt. Verbunden mit einer Mikrotex-Außenschicht ist diese Materialmischung unsere voluminöseste Option, die Komfort, Vielseitigkeit und Haltbarkeit vereint.

VENTO  
**MICROTEX  
TACKY**

Intended use: ROAD RACING

Microtex is the thinnest option for pin-sharpening handling and control. Tacky finish aids a sticky nonslip surface with a raised texture for ultimate grip in every condition.

Microtex ist die dünnste Option für ultra präzises Handling und Kontrolle. Das Tacky Finish sorgt für eine rutschfeste Oberfläche mit einer erhabenen Textur für ultimativen Grip unter allen Bedingungen.



ARTICLE	EAN	MODEL	COLOR	CONSTRUCTION	TOUCH	THICKNESS	SRP (€)
BT09000A00042	8021890466457	<b>Vento Microtex Tacky</b>	Black	Microtex	Tacky	2mm	40,90
BT09000A00044	8021890466464		White				40,90
BT09000A00012	8021890466440		Red				40,90
BT09000A00047	8021890466488		Orange Fluo				40,90
BT09000A00050	8021890466495		Pink Fluo				40,90
BT09000A00046	8021890466471		Yellow Fluo				40,90
BT09000A00051	8021890466501		Lilla Fluo				40,90
BT09000A00009	8021890466433		Celeste				40,90
BT15000A20042	8021890482693		Black/Celeste				43,90
BT15000A40042	8021890482716		Black/White				43,90
BT15000A50042	8021890482723		Black/Red				43,90
BT15000A60042	8021890482730		Black/Grey				43,90

## VENTO SOLOCUSH TACKY

Intended use: ROAD RACING

Solocush is our most streamlined cushioned construction, a single-layer chunky platform to rest on during longer rides without compromises on weight. Tacky finish aids a sticky nonslip surface with a raised texture for ultimate grip in every condition.

Solocush ist unsere geradlinigste gepolsterte Konstruktion, eine einlagige, voluminöse Plattform, auf der man bei längeren Fahrten entspannt sitzen kann, ohne dabei Kompromisse beim Gewicht einzugehen. Das Tacky Finish sorgt für eine rutschfeste Oberfläche mit einer erhabenen Textur für ultimativen Grip unter allen Bedingungen.



ARTICLE	EAN	MODEL	COLOR	CONSTRUCTION	TOUCH	THICKNESS	SRP (€)
BT11000A00042	8021890466686		Black				43,90
BT11000A00044	8021890466693		White				43,90
BT11000A00055	8021890467034		Blue				43,90
BT11000A00025	8021890466679		Green				43,90
BT11000A00012	8021890466655		Red				43,90
BT11000A00011	8021890466648		Pink				43,90
BT11000A00014	8021890466662		Yellow				43,90
BT11000A00047	8021890466716	<b>Vento Solocush Tacky</b>	Orange Fluo	Solocush	Tacky	2,7mm	43,90
BT11000A00050	8021890466723		Pink Fluo				43,90
BT11000A00046	8021890466709		Yellow Fluo				43,90
BT11000A00051	8021890466730		Lilla Fluo				43,90
BT11000A00009	8021890466631		Celeste				43,90
BT11000A00057	8021890498885		Light Grey				43,90
BT11000A00058	8021890498892		Dark Grey				43,90
BT11000A00059	8021890498908		Mint Green				43,90



TEMPO  
**MICROTEX  
CLASSIC**

Intended use: ROAD

Microtex is the thinnest option for pin-sharpening handling and control. Classic touch is a durable perforated leather-like texture, with traditional aesthetic and smooth surface slide easily to different riding positions.

Microtex ist die dünnste Option für ultra präzises Handling und Kontrolle. Classic Touch ist eine haltbare, perforierte lederähnliche Textur, mit traditioneller Ästhetik und glatter Oberfläche, mit der Sie leicht in verschiedene Fahrpositionen gleiten.



TEMPO  
**MICROTEX BOND CUSH  
CLASSIC**

Intended use: ROAD

Bondcush is layered mid-padding polymer foam that aids the absorption of road buzz. Bonded to a microtex outer layer this material blend is our chunkiest option that combines comfort, versatility and durability, ideal to tackle all kind of roads. Classic touch is a durable perforated leather-like texture, with traditional aesthetic and smooth surface slide easily to different riding positions.

Bondcush ist ein geschichteter Polymer-Schaumstoff mit mittlerer Polsterung, der zur Dämpfung von Straßengeräuschen beiträgt. Auf eine Mikrotex-Außenschicht geklebt, ist diese Materialmischung unsere voluminöseste Option, die Komfort, Vielseitigkeit und Strapazierfähigkeit vereint und ideal für alle Arten von Straßen ist. Classic Touch ist ein robustes, perforiertes, lederähnliches Gewebe mit traditioneller Ästhetik und glatter Oberfläche, auf der man leicht in verschiedene Sitzpositionen gleiten kann.



ARTICLE	EAN	MODEL	COLOR	CONSTRUCTION	TOUCH	THICKNESS	SRP (€)
BT10000A00032	8021890466600	Tempo Microtex Classic	Black	Microtex	Classic	2mm	23,90
BT10000A00010	8021890466549		White				23,90
BT10000A00055	8021890467027		Blue				23,90
BT10000A00025	8021890466594		Green				23,90
BT10000A00012	8021890466563		Red				23,90
BT10000A00011	8021890466556		Pink				23,90
BT10000A00014	8021890466570		Yellow				23,90
BT10000A00045	8021890466617		Orange				23,90
BT10000A00018	8021890466587		Honey				23,90
BT10000A00006	8021890466525		Silver				23,90
BT10000A00009	8021890466532		Celeste				23,90
BT13000A00032	8021890466891	Tempo Microtex Bondcush Classic	Black	Microtex Bondcush	Classic	3mm	30,90
BT13000A00010	8021890466839		White				30,90
BT13000A00018	8021890466877		Honey				30,90

## TEMPO

**MICROTEX BONDCUSH  
SOFT**

Intended use: ROAD

Bondcush is layered mid-padding polymer foam that aids the absorption of road buzz. Bonded to a microtex outer layer this material blend is our chunkiest option that combines comfort, versatility and durability, ideal to tackle all kind of roads. Soft touch is a matt-look, silky moisture absorbing surface.

Bondcush ist ein geschichteter Polymer-Schaumstoff mit mittlerer Polsterung, der zur Dämpfung von Straßengeräuschen beiträgt. Auf eine Mikrotex-Außenschicht geklebt, ist diese Materialmischung unsere voluminöseste Option, die Komfort, Vielseitigkeit und Strapazierfähigkeit vereint und ideal für alle Arten von Straßen ist. Soft Touch ist eine matte, seidige, Feuchtigkeit absorbierende Oberfläche.



## TEMPO

**MICROTEX BONDCUSH  
TACKY - Les Classiques**

Intended use: ROAD

Bondcush is layered mid-padding polymer foam that aids the absorption of road buzz. Bonded to a microtex outer layer this material blend is our chunkiest option that combines comfort, versatility and durability, ideal to tackle all kind of roads. Tacky finish aids a sticky nonslip surface with a raised texture for ultimate grip in every condition.

Bondcush ist ein geschichteter Polymer-Schaumstoff mit mittlerer Polsterung, der zur Dämpfung von Straßengeräuschen beiträgt. Auf eine Mikrotex-Außenschicht geklebt, ist diese Materialmischung unsere voluminöseste Option, die Komfort, Vielseitigkeit und Strapazierfähigkeit vereint und ideal für alle Arten von Straßen ist. Tacky Finish bietet eine klebrige, rutschfeste Oberfläche mit einer erhabenen Textur für ultimative Griffbarkeit unter allen Bedingungen.

**Le Classiques**  
Limited Edition



ARTICLE	EAN	MODEL	COLOR	CONSTRUCTION	TOUCH	THICKNESS	SRP (€)
BT14000A00002	8021890466914	<b>Tempo Microtex Bondcush Soft</b>	Black	Microtex Bondcush	Soft	3mm	30,90
BT14000A00012	8021890466969	<b>Tempo Microtex Bondcush Soft</b>	Red	Microtex Bondcush	Soft	3mm	30,90
BT16000A00042	8021890497543	<b>Tempo Microtex Bondcush Tacky</b>	Le Classiques	Microtex Bondcush	Tacky	3mm	43,90

TERRA

# MICROTEX BOND CUSH TACKY

Intended use: GRAVEL

Bondcush is layered mid-padding polymer foam that aids the absorption of road buzz. Bonded to a microtex outer layer this material blend is our chunkiest option that combines comfort, versatility and durability, ideal to tackle all kind of roads. A sticky gel backing serves two functions: it replaces the adhesive tape for an easy removal during cleaning and damps off-road chatter without feeling too squishy. Tacky finish aids a sticky nonslip surface for ultimate grip in every condition.

Bondcush ist ein geschichteter Polymer-Schaumstoff mit mittlerer Polsterung, der zur Dämpfung von Straßengeräuschen beiträgt. Auf eine Mikrotex-Außenschicht geklebt, ist diese Materialmischung unsere voluminöseste Option, die Komfort, Vielseitigkeit und Strapazierfähigkeit vereint und ideal für alle Arten von Straßen ist. Ein haftendes Gel-Trägermaterial erfüllt zwei Funktionen: Es ersetzt das Klebeband, so dass es bei der Reinigung leicht entfernt werden kann, und es dämpft Vibrationen im Gelände, ohne sich zu schwammig anzufühlen. Tacky Finish bietet eine klebrige, rutschfeste Oberfläche mit einer erhabenen Textur für ultimative Griffbarkeit unter allen Bedingungen.



ARTICLE	EAN	MODEL	COLOR	CONSTRUCTION	TOUCH	THICKNESS	SRP (€)
BT12000A00002	8021890466747	<b>Terra Microtex Bondcush Tacky</b>	Black	Microtex Bondcush	Tacky	3mm	43,90
BT12000A00016	8021890466761		White				43,90
BT12000A00012	8021890466754		Red				43,90
BT12000A00052	8021890466778		Dark Blue				43,90
BT12000A00053	8021890466785		Green/Blue				43,90
BT12000A00054	8021890466792		Brown				43,90
BT12000A00057	8021890498915		Light Grey				43,90

VENTO

**MICROTEX TACKY 2mm  
BOX 10 KITS (20 ROLLS)**

**1 kit contains:**

- 2 rolls of Vento Microtex Tacky 2mm black tape
- 2 extra tape strips
- 2 bar plugs
- 2 finishing tapes

**1 Set enthält:**

- 2 Rollen schwarzes Vento Microtex 2mm Lenkerband
- 2 zusätzliche Lenkerbandstücke
- 2 Lenkerendstopfen
- 2 Finish-Klebebänder



TEMPO

**BONDCUSH SOFT 3mm  
BOX 10 KITS (20 ROLLS)**

**1 kit contains:**

- 2 rolls of Tempo Bondcush 3mm Soft black tape
- 2 extra tape strips
- 2 bar plugs
- 2 finishing tapes

**1 Set enthält:**

- 2 Rollen schwarzes Tempo Bondcush 3mm Soft Lenkerband
- 2 zusätzliche Lenkerbandstücke
- 2 Lenkerendstopfen
- 2 Finish-Klebebänder



**BAR GEL KIT**

- 2 curved cut-to-custom-fit bargel
- 2 straight cut-to-cut-custom-fit bargel
- 2 top wrap strips

- 2 gebogene, cut-to-custom-fit Bargel
- 2 gerade abgeschnittene, cut-to-custom-fit Bargel
- 2 Top-Wrap-Streifen



ARTICLE	EAN	MODEL	COLOR	CONSTRUCTION	TOUCH	THICKNESS	SRP (€)
FZKTAPE000000	8021890579638	<b>Vento Microtex Tacky 10 Kits (20 rolls)</b>	Black	Microtex	Tacky	2mm	-
FZKTAPE020000	8021890579652	<b>Tempo Bondcush Soft 10 Kits (20 rolls)</b>	Black	Microtex Bondcush	Soft	3mm	-
BG02000A10003	8021890580634	<b>Bar Gel Kit</b>	4 Pieces of Gel (2 curved + 2 straight) + 2 wrap strips				20



crankbrothers







## PEDALS

### A REVOLUTION IN TERMS OF PERFORMANCE AND RELIABILITY

NEW MODELS, ADVANCED TECHNOLOGIES AND HIGH-END COMPONENTS  
ARE COMBINED IN OUR PEDALS LINE.

**EINE REVOLUTION IN SACHEN PERFORMANCE UND ZUVERLÄSSIGKEIT**  
NEUE MODELLE, VERBESSERTE TECHNOLOGIE UND HIGH-END KOMPONENTEN,  
ZUSAMMENGEFASST IN UNSERER PEDAL PALETTE.



## PREMIUM INTERNAL COMPONENTS PREMIUM BAUTEILE

### ENDURO CARTRIDGE BEARING\* | ENDURO WÄLZLAGER\*

#### PREMIUM OUTBOARD BEARING

- Designed specifically for pedals (low speed, high torque)
- Superior materials, grease, and sealing
- Superior corrosion resistance
- Superior tolerances for a precise fit

(\*) In all new pedals instead of the Enduro cartridge bearing will be installed a Enduro Max cartridge bearing, for increased reliability.



#### PREMIUM KUGELLAGER

- Speziell für Pedale entwickelt (niedrige Geschwindigkeit, hohes Drehmoment)
- Höherwertige Materialien, Fette und Dichtungen
- Überragende Korrosionsbeständigkeit
- Ausgezeichnete Toleranzen für eine präzise Passform

(\*) Um die Zuverlässigkeit zu erhöhen, in allen neuen Pedalen wird anstelle des Enduro Cartridge-Lagers ein Enduro Max Cartridge-Lager verbaut.

### IGUS LL-GLIDE BEARING | IGUS LL-GLEITLAGER

#### PREMIUM INBOARD BEARING

- Exclusive formulation for Crankbrothers
- 8x better performance in igus lab testing
- Up to 74x better performance in our most aggressive in-house lab testing
- Performs in the most adverse condition



#### PREMIUM INBOARD LAGER

- Exklusiv für Crankbrothers hergestellt
- 8x bessere Performance im Icus Labor Test
- Bis zu 74x bessere Performance in unseren härtesten In-House Labor Tests
- Funktioniert auch unter widrigsten Bedingungen

### DOUBLE SEAL SYSTEM | DOPPEL DICHTUNGS SYSTEM

#### DOUBLE LIP INTERNAL SEAL EXTERNAL SEAL

- Prevents water and debris from entering the pedal
- Lab tested and ride proven in extreme conditions
- Prevents contamination and extends life of pedal

#### DOUBLE LIP, INNERE UND ÄUSSERE DICHTUNG

- Verhindert dass Wasser und Staub ins Pedalinnere eindringen
- Im Labor und unter reellen Bedingungen in extremen Situationen getestet
- Verhindert Verschmutzung und verlängert die Funktionsfähigkeit des Pedals



internal seal double-lip  
interne Dichtung mit  
Doppellippe

external seal  
externe Dichtung







# CLIP-IN PEDALS MALLET DH



MALLET DH 11



MALLET DH RACE

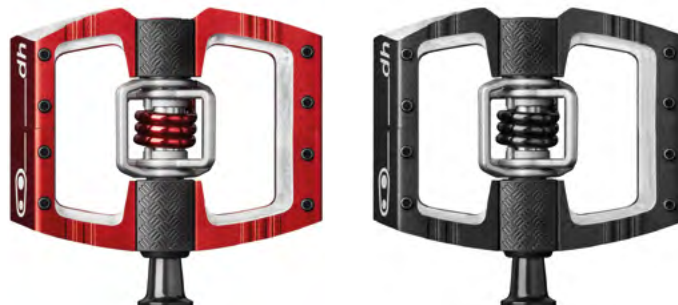

ARTICLE	UPC	MODEL	BODY COLOR	SPRING COLOR	WEIGHT*	WING MATERIAL	Q-FACTOR	PRICE (€)
16096	641300160966	<b>mallet dh 11</b>	black	gold	445g	titanium	57mm	350
16094	641300160942	<b>mallet dh race</b>	black	black	479g	cast steel	57mm	180
16095	641300160959		red	red				180

(\*) All weights are per pair of pedals | Alle Gewichte gelten pro Pedalpaar

CLIP-IN PEDALS  
MALLET E

11 MALLET E 11



MALLET E



MALLET E LS  
(LONG SPINDLE)



SPLATTER EDITION

ARTICLE	UPC	MODEL	BODY COLOR	SPRING COLOR	WEIGHT*	WING MATERIAL	Q-FACTOR	PRICE (€)
16093	641300160935	<b>mallet e 11</b>	black	gold	385g	titanium	52mm	350
15990	641300159908	<b>mallet e</b>	black	black	419g	cast steel	52mm	180
15991	641300159915		electric blue	blue				
16080	641300160805	<b>mallet e ls</b>	blue**	black	424g	cast steel	57mm	180
16247	641300162472		silver**	black				
16708	641300167088	<b>mallet e ls</b>	lime green/black**	black	424g	cast steel	57mm	180
16710	641300167101	<b>splatter edition</b>	blue/black**	black				

(\*) All weights are per pair of pedals | Alle Gewichte gelten pro Pedalpaar

(\*\*) Until sold out | Solange der Vorrat reicht



## CLIP-IN PEDALS MALLET TRAIL

MALLET TRAIL

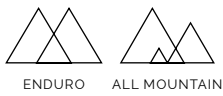

## CLIP-IN PEDALS MALLET 3-2

3 MALLET 3



2 MALLET 2



ARTICLE	UPC	MODEL	BODY COLOR	SPRING COLOR	WEIGHT*	WING MATERIAL	Q-FACTOR	PRICE (€)
16759	641300167590	<b>mallet trail</b>	black	black				180
16760	641300167606		champagne	black	344g	cast steel	57mm	180
16761	641300167613		purple	black				180
15988	641300159885	<b>mallet 3</b>	raw/black	blue	499g	cast steel	52mm	150
15989	641300159892		raw/red**	red				
15987	641300159878	<b>mallet 2</b>	raw/green**	black	508g	stamped steel	52mm	100
15986	641300159861		raw/silver	black				

(\*) All weights are per pair of pedals | Alle Gewichte gelten pro Pedalpaar

(\*\*) Until sold out | Solange der Vorrat reicht

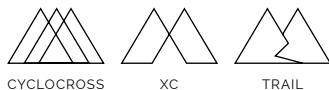

CYCLOCROSS

XC

TRAIL

CLIP-IN PEDALS

CANDY

11

CANDY 11



7

CANDY 7



3

CANDY 3



ARTICLE	UPC	MODEL	BODY COLOR	SPRING COLOR	WEIGHT*	WING MATERIAL	TRACTION PADS	PRICE (€)
15984	641300159847	<b>candy 11</b>	gold	gold	249g	titanium	integrated	500
16178	641300161789		black/electric blue	black				180
15981	641300159816	<b>candy 7</b>	black	black	320g	cast steel	integrated	180
15982	641300159823		red	red				180
16175	641300161758		black	black				150
16177	641300161772	<b>candy 3</b>	dark red**	red	340g	cast steel	included	150
16176	641300161765		slate blue	blue				150

(\*) All weights are per pair of pedals | Alle Gewichte gelten pro Pedalpaar

(\*\*) Until sold out | Solange der Vorrat reicht

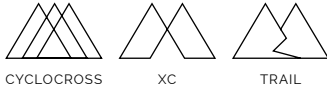

# CLIP-IN PEDALS CANDY

2 CANDY 2



1 CANDY 1

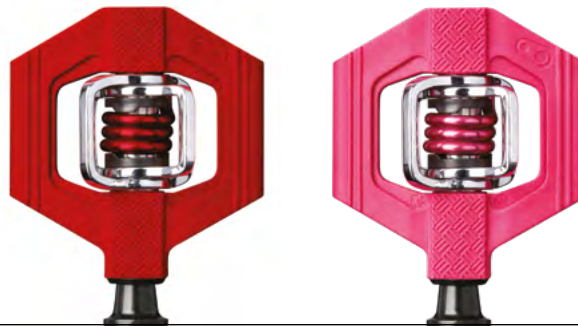

ARTICLE	UPC	MODEL	BODY COLOR	SPRING COLOR	WEIGHT*	WING MATERIAL	TRACTION PADS	PRICE (€)
16173	641300161734	<b>candy 2</b>	dark grey	black	355g	stamped steel	optional	100
16634	641300166340		red	black				100
16169	641300161697	<b>candy 1</b>	black	black	294g	stamped steel	not compatible	60
16171	641300161710		light blue	blue				60
16170	641300161703		red	red				60
16172	641300161727		pink	pink				60

(\*) All weights are per pair of pedals | Alle Gewichte gelten pro Pedalpaar

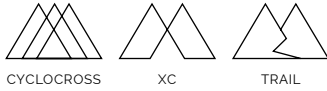

CYCLOCROSS

XC

TRAIL

## CLIP-IN PEDALS EGGBEATER

11 EGGBEATER 11



3 EGGBEATER 3

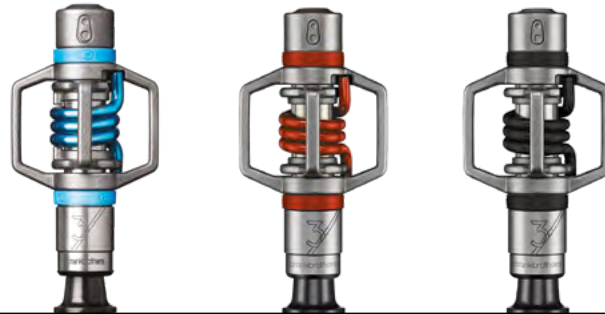

2 EGGBEATER 2



1 EGGBEATER 1

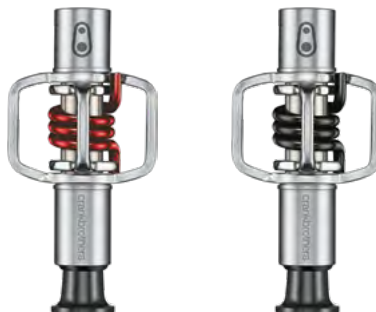

ARTICLE	UPC	MODEL	BODY COLOR	SPRING COLOR	WEIGHT*	WING MATERIAL	TRACTION PADS	PRICE (€)
11495	641300114952	<b>eggbeater 11</b>	gold	gold	179g	titanium	1mm included	500
16098	641300160980	<b>eggbeater 3</b>	light blue	electric blue	280g	cast steel	1mm included	150
15319	641300153197		red	red				
15859	641300158598		black	black				
15317	641300153173	<b>eggbeater 2</b>	black	black	285g	stamped steel	optional	100
15985	641300159854		black	green				
14792	641300147929	<b>eggbeater 1</b>	silver	red	290g	stamped steel	not compatible	60
14791	641300147912		silver	black				

(\*) All weights are per pair of pedals | Alle Gewichte gelten pro Pedalpaar



# HYBRID PEDALS DOUBLE SHOT

3

DOUBLE SHOT 3

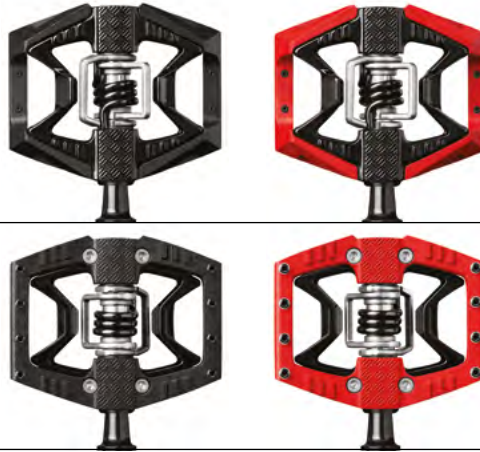

CLIP-IN SIDE

FLAT SIDE

2

DOUBLE SHOT 2



CLIP-IN SIDE

FLAT SIDE

1

DOUBLE SHOT 1

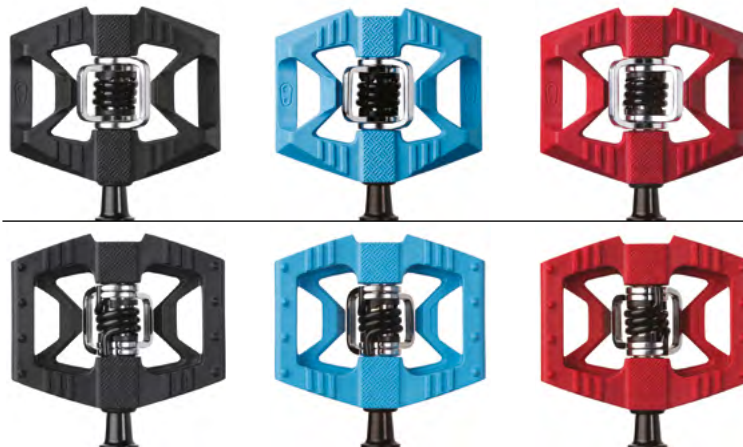

CLIP-IN SIDE

FLAT SIDE

ARTICLE	UPC	MODEL	BODY COLOR	SPRING COLOR	WEIGHT*	BODY MATERIAL	PINS	Q-FACTOR	PRICE (€)
16111	641300161116	<b>double shot 3</b>	black	black	403g	aluminum	8 adjustable	57mm	150
16110	641300161109		red/black	black					150
16006	641300160065	<b>double shot 2</b>	black/silver	blue	395g	aluminum	8 molded	57mm	100
16007	641300160072		orange/black	orange					100
16077	641300160775		blue/black	black					100
16179	641300161796	<b>double shot 1</b>	black	black	331g	composite	8 molded	57mm	60
16181	641300161819		blue	black					60
16180	641300161802		red	black					60

(\*) All weights are per pair of pedals | Alle Gewichte gelten pro Pedalpaar





## FLAT PEDALS

### FIND YOUR PERFECT SIZE

WE ANALYZED OUTSOLE PROFILES FROM THE TOP MOUNTAIN BIKE SHOE BRANDS AND DISCOVERED TWO DISTINCT SURFACE AREAS TO OPTIMIZE THE SHOE/PEDAL INTERFACE FOR THE ENTIRE RANGE OF SHOE SIZES.

#### **FINDE DEINE IDEALE GRÖSSE**

WIR HABEN DIE SOHLENPROFILE DER TOP MOUNTAINBIKESCHUH HERSTELLER ANALYSIERT UND SIND DADURCH AUF ZWEI WESENTLICHE PEDALKÖRPERGRÖSSEN GESTOSSEN MIT DENEN WIR EINEN BESSEREN HALT ZWISCHEN SCHUH UND PEDAL FÜR ALLE SCHUHGRÖSSEN ERMÖGLICHEN KÖNNEN.

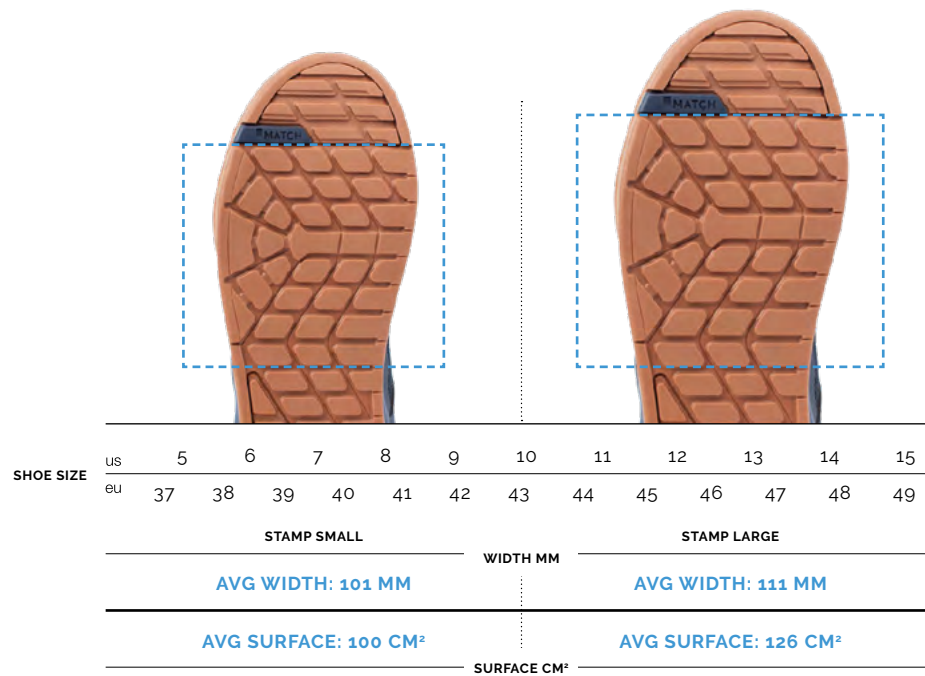

### OPTIMAL SURFACE AREA

- Based on research of shoe sizes & outsoles surfaces
- Two distinct sizes with optimal surface areas for different shoe size ranges
- Maximizes grip, support, and interface with pedal
- Minimizes necessary weight and rock-strikes
- Auf Grundlage der Recherche von Schuhgrößen und Sohlenoberflächen
- Zwei unterschiedliche Größen mit optimaler Fläche für die verschiedenen Schuhgrößen
- Maximierter Grip, Support und bessere Verbindung mit dem Pedal
- Minimiertes Gewicht und geringeres Risiko von "rock strikes"

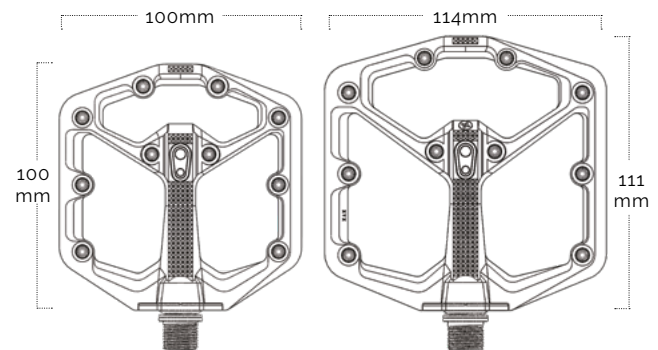

### MINIMUM PROFILE/MAXIMUM CONCAVITY | MINIMALES PROFIL/MAXIMALE KONKAVE

- Minimal profile, 11-13 mm
- Thinner profile than the competition
- Reduces weight and rock strikes
- Concave platform cups the foot for secure foothold and better grip
- More concave than the competition
- Geringes Profil, 11-13 mm
- Dünneres Profil als die Mitbewerber
- Reduziertes Gewicht und geringere Gefahr von "rock strikes"
- Konkave Standfläche bettet den Fuß für sicheren Halt und besseren Grip
- Mehr Konkave als bei Mitbewerbern

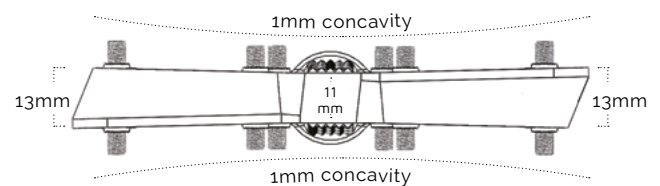



FLAT PEDALS

STAMP



11 STAMP 11



7 STAMP 7



7 STAMP 7  
SPLATTER EDITION



ARTICLE	UPC	MODEL	SIZE	BODY COLOR	WEIGHT*	BODY MATERIAL	THICKNESS	PRICE (€)
16165	641300161659	<b>stamp 11 (large)</b>	large	black/gold	325g	aluminum	11/13 mm	300
16166	641300161666	<b>stamp 11 (small)</b>	small	black/gold	299g	aluminum	11/13 mm	300
16002	641300160027	<b>stamp 7 (large)</b>	large	black	375g	aluminum	11/13 mm	180
16003	641300160034		large	red				180
16635	641300166357		large	electric blue				180
16746	641300167460		large	high polish silver				190
16004	641300160041	<b>stamp 7 (small)</b>	small	black	345g	aluminum	11/13 mm	180
16005	641300160058		small	red				180
16636	641300166364		small	electric blue				180
16747	641300167477		small	high polish silver				190
16702	641300167026	<b>stamp 7 (large) splatter edition</b>	large	lime green**	375g	aluminum	11/13 mm	180
16703	641300167033	<b>stamp 7 (small) splatter edition</b>	small	lime green**	345g	aluminum	11/13 mm	180
16705	641300167057		small	red**				180
16707	641300167071		small	blue**				180

(\*) All weights are per pair of pedals | Alle Gewichte gelten pro Pedalpaar

(\*\*) Until sold out | Solange der Vorrat reicht



# FLAT PEDALS STAMP



## 3 STAMP 3



## 2 STAMP 2



## 1 STAMP 1



ARTICLE	UPC	MODEL	SIZE	BODY COLOR	WEIGHT*	BODY MATERIAL	THICKNESS	PRICE (€)
16366	641300163660	<b>stamp 3 (large)</b>	large	black magnesium	386g	magnesium	13.5/16.5 mm	140
16367	641300163677		large	grey magnesium				
16368	641300163684	<b>stamp 3 (small)</b>	small	black magnesium	351g	magnesium	13.5/16.5 mm	140
16369	641300163691		small	grey magnesium				
16362	641300163622	<b>stamp 2 (large)</b>	large	raw silver	494g	die cast aluminum	13.5/16.5 mm	100
16363	641300163639		large	black				
16364	641300163646	<b>stamp 2 (small)</b>	small	raw silver	439g	die cast aluminum	13.5/16.5 mm	100
16365	641300163653		small	black				
16267	641300162670	<b>stamp 1 (large)</b>	large	black	329g	composite	13mm	50
16268	641300162687		large	red				
16269	641300162694		large	blue				
16388	641300163882		large	orange				
16270	641300162700	<b>stamp 1 (small)</b>	small	black	299g	composite	13mm	50
16271	641300162717		small	red				
16272	641300162724		small	blue				
16392	641300163929		small	orange				

(\*) All weights are per pair of pedals | Alle Gewichte gelten pro Pedalpaar



#### STAMP 1 GEN 2 | KEY FEATURES

- Small/Large size-specific for optimal shoe/pedal interface
- Reinforced composite body is lightweight, improves deflection and reduces hang-up during rock strikes
- Concave platform for secure foothold (13.5-15.5mm thin)
- 10 Replaceable traction pins
- Premium bearings & seal system (Same internals as Stamp 7)
- igus LL-glide bearings (inner and outer)
- Forged SCM 435 chromoly steel spindle
- Serviceable
- 5-year warranty

#### **GRIP:**

- Concave platform for secure foothold (13.5-15.5mm thin)
- 10 replaceable traction pins per side

#### **DURABILITY:**

- New body shape to reinforce spindle and reduce hang-up during rock strikes
- Premium Stamp 7 internals for better sealing and durability

- Größe spezifisch für optimale Schuh-/Pedalverbindung (klein/groß)
- Verstärkter Verbundwerkstoffkörper ist leicht, verbessert die Durchbiegung und reduziert Hängenbleiben bei Felsaufschlägen
- Konkave Plattform für sicheren Halt (13,5-15,5 mm dünn)
- 10 austauschbare Traktionsstifte
- Hochwertiges Lager und Dichtungssystem (gleiche Innenteile wie Stamp 7)
- Igus LL-Glide-Lager (innen und außen)
- Geschmiedete SCM 435 Chrom-Stahlachse
- Wartungsfähig
- 5 Jahre Garantie

#### **GRIFF:**

- Konkave Plattform für sicheren Halt (13,5-15,5 mm dünn)
- 10 austauschbare Traktionsstifte pro Seite

#### **HALTBARKEIT:**

- Neue Gehäuseform zur Verstärkung der Achse und Reduzierung des Hängenbleibens bei Felsaufschlägen
- Hochwertige Stamp 7-Innenteile für bessere Abdichtung und Haltbarkeit

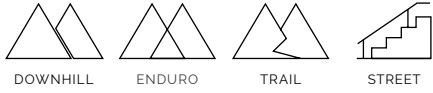

# FLAT PEDALS STAMP 1 GEN 2

**NEW**



1 STAMP 1 GEN 2



ARTICLE	UPC	NEW	MODEL	SIZE	BODY COLOR	WEIGHT*	BODY MATERIAL	THICKNESS	PRICE (€)
16809	641300168092	<b>NEW</b>	stamp 1 - GEN 2 (large)	large	black	348g	reinforced composite	13.5/15.5mm	60
16811	641300168115	<b>NEW</b>		large	red				60
16813	641300168139	<b>NEW</b>		large	orange				60
16815	641300168153	<b>NEW</b>		large	navy blue				60
16817	641300168177	<b>NEW</b>		large	purple				60
16810	641300168108	<b>NEW</b>	stamp 1 - GEN 2 (small)	small	black	299g	reinforced composite	13.5/15.5mm	60
16812	641300168122	<b>NEW</b>		small	red				60
16814	641300168146	<b>NEW</b>		small	orange				60
16816	641300168160	<b>NEW</b>		small	navy blue				60
16818	641300168184	<b>NEW</b>		small	purple				60

(\* ) All weights are per pair of pedals | Alle Gewichte gelten pro Pedalpaar

# PEDALS ACCESSORIES

## CLEAT COLLECTION

STANDARD RELEASE 6° FLOAT CLEAT

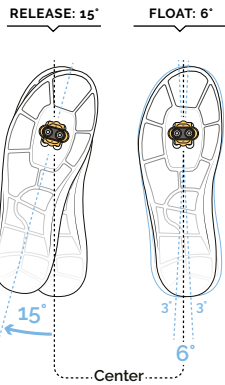

STANDARD RELEASE 0° FLOAT CLEAT

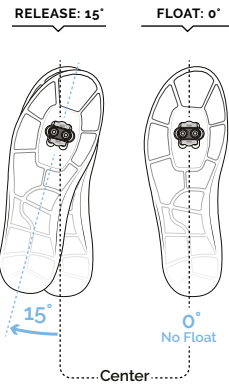

EASY RELEASE 6° FLOAT CLEAT

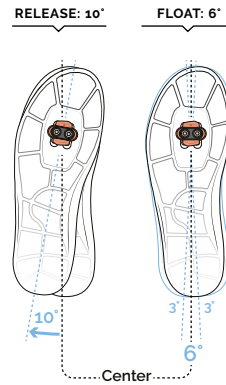
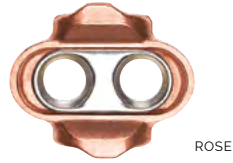

EASY RELEASE 0° FLOAT CLEAT

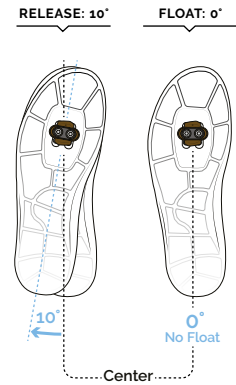

## CLEAT POP KIT (INCLUDES 16 PAIRS OF CLEATS)



ARTICLE	UPC	MODEL	PRICE (€)
10060	641300600127	cleat standard release 6 degree	27
15338	641300153388	cleat standard release 0 degree	27
16275	641300162755	cleat easy release 6 degree	27
16276	641300162762	cleat easy release 0 degree	27
16353	641300163530	cleat kit 16 units with fitting tool and display GERMAN	-



## PEDALS ACCESSORIES

### CLEAT AND PEDAL ACCESSORIES



MATCH SHOE SHIM

METAL SHOE SHIELDS

3 HOLE ROAD CLEAT

CANDY 7/11 TRACTION PADS

CANDY 2/3 TRACTION PADS 2017 - 2018

CANDY 2/3/11 TRACTION PADS 2010 - 2016

MALLET E/DH TRACTION PADS

EGGBEATER 1mm TRACTION PAD

### REFRESH KIT COLLECTION



LONG SPINDLE KIT

TITANIUM SPINDLE KIT

REFRESH KIT

REFRESH KIT EGGBEATER 11 / CANDY 11

REFRESH KIT STAMP 7 / 11

REFRESH KIT DOUBLE SHOT 2 / 3

10MM PIN KIT

8MM PIN KIT

ARTICLE	UPC	COLLECTION	MODEL	PRICE (€)
16685	641300166852	cleat and pedal accessories	match shoe shim	5
10000	641300670007		metal shoes shields/pair	10
15289	641300152893		3 hole cleat kit	30
16057	641300160577		candy 7/11 traction pads	15
16217	641300162175		candy 2/3 traction pads (model 2017)	10
13282	641300132826		candy 2/3/11 traction pads (model 2010-2016)	10
16058	641300160584		mallet e/dh traction pads	15
16509	641300165091		eggbeater 1mm traction pad	10
16067	641300160676	refresh kit collection	long spindle kit	50
16068	641300160683		titanium spindle kit	180
16051	641300160515		refresh kit 2010-present	29
16229	641300162298		refresh kit eggbeater / candy 11	29
16273	641300162731		refresh kit stamp 7/11	25
16274	641300162748		refresh kit double shot 2/3	30
13890	641300138903		flats 10mm pin kit	12
13891	641300138910		flats 8mm pin kit	12





## FOOTWEAR

# THE CRANKBROTHERS SHOE COLLECTION

THE NEW LINE OF SHOES HAVE BEEN ENGINEERED WITH A SINGLE GOAL - CREATE THE ULTIMATE MTB SHOE FOR TRAIL AND GRAVITY RIDING. ADDRESSING A NUMBER OF ISSUES COMMONLY FOUND WITH EXISTING SHOES, THEY HAVE BEEN DESIGNED TO OFFER THE PERFECT BALANCE OF OPTIMISED SHOE-PEDAL INTERFACE WITH OFF-BIKE CHARACTERISTICS.

DIE NEUE SCHUHSERIE WURDE MIT EINEM EINZIGEN ZIEL ENTWICKELT - DEN ULTIMATIVEN MTB-SCHUH FÜR DAS TRAIL- UND GRAVITY-FAHREN ZU SCHAFFEN. BEI DER ENTWICKLUNG DIESER SCHUHE WURDEN VERSCHIEDENE ASPEKTE BERÜCKSICHTIGT, DIE BEI BESTEHENDEN SCHUHEN HÄUFIG BEMÄNGELT WERDEN. ZUDEM BIETEN DIE SCHUHE DIE PERFEKTE BALANCE EINER OPTIMIERTEN SCHUH - PEDAL VERBINDUNG GEPAART MIT OFF-BIKE EIGENSCHAFTEN.



# MATCH SYSTEM



## TO MATCH THE PEDAL WITH THE SHOE UM DAS PEDAL MIT DEM SCHUH IN EINKLANG ZU BRINGEN

MATCH IS AN INTEGRATED DESIGN APPROACH THAT CONSIDERS THE PEDAL AND THE SHOE AS A UNIFIED SYSTEM TO PROVIDE THE OPTIMAL INTERFACE.

MATCH IST EIN INTEGRIERTER DESIGN-ANSATZ, DER PEDAL UND SCHUH ALS EIN EINHEITLICHES SYSTEM BETRACHTET, UM DIE OPTIMALE VERBINDUNG ZU SCHAFFEN.

# MATCH SHIM CHART



SPD



CRANKBROTHERS



CLEAT ONLY

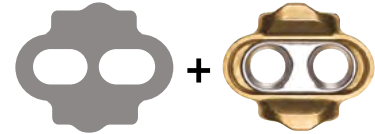

SHIM + CLEAT

## OPTIMIZED FOR ANY MTB CLIP-IN SYSTEM OPTIMIERT FÜR JEDES MTB CLIP-IN SYSTEM

OPTIMIZED ENGAGEMENT FOR CB CLIP-IN SYSTEMS  
OPTIMIZED ENGAGEMENT OVER TIME FOR CB PEDALS

OPTIMIERTES EINRASTEN FÜR CB-CLIP-IN-SYSTEME  
OPTIMIERTES EINSTELLUNG DER CB-PEDALE IM LAUFE DER ZEIT

### SHIM THICKNESS CHART:

















GREY: 1.5mm

BLACK: 1mm

BLACK: 1mm



### PEDALS

	MALLET DH	MALLET E	MALLET TRAIL	CANDY
	 PRE-INSTALLED	 PRE-INSTALLED	 USE BLACK SHIM INCLUDED WITH PEDALS / USE #16917 (AVAILABLE SEPARATELY)	<b>X</b> SHIM NOT RECOMMENDED
	 PRE-INSTALLED	 PRE-INSTALLED	 USE BLACK SHIM INCLUDED WITH PEDALS / USE #16917 (AVAILABLE SEPARATELY)	<b>X</b> SHIM NOT RECOMMENDED
	 INCLUDED IN SHOE PACKAGING	 INCLUDED IN SHOE PACKAGING	 PRE-INSTALLED	 PRE-INSTALLED
	<b>X</b> SHIM NOT RECOMMENDED	<b>X</b> SHIM NOT RECOMMENDED	 USE BLACK SHIM INCLUDED WITH PEDALS / USE #16917 (AVAILABLE SEPARATELY)	 USE BLACK SHIM INCLUDED WITH PEDALS / USE #16917 (AVAILABLE SEPARATELY)

SHOES



# MATCH BOX



EASY IN AND OUT  
EINFACHES EIN-UND AUSKLICKEN

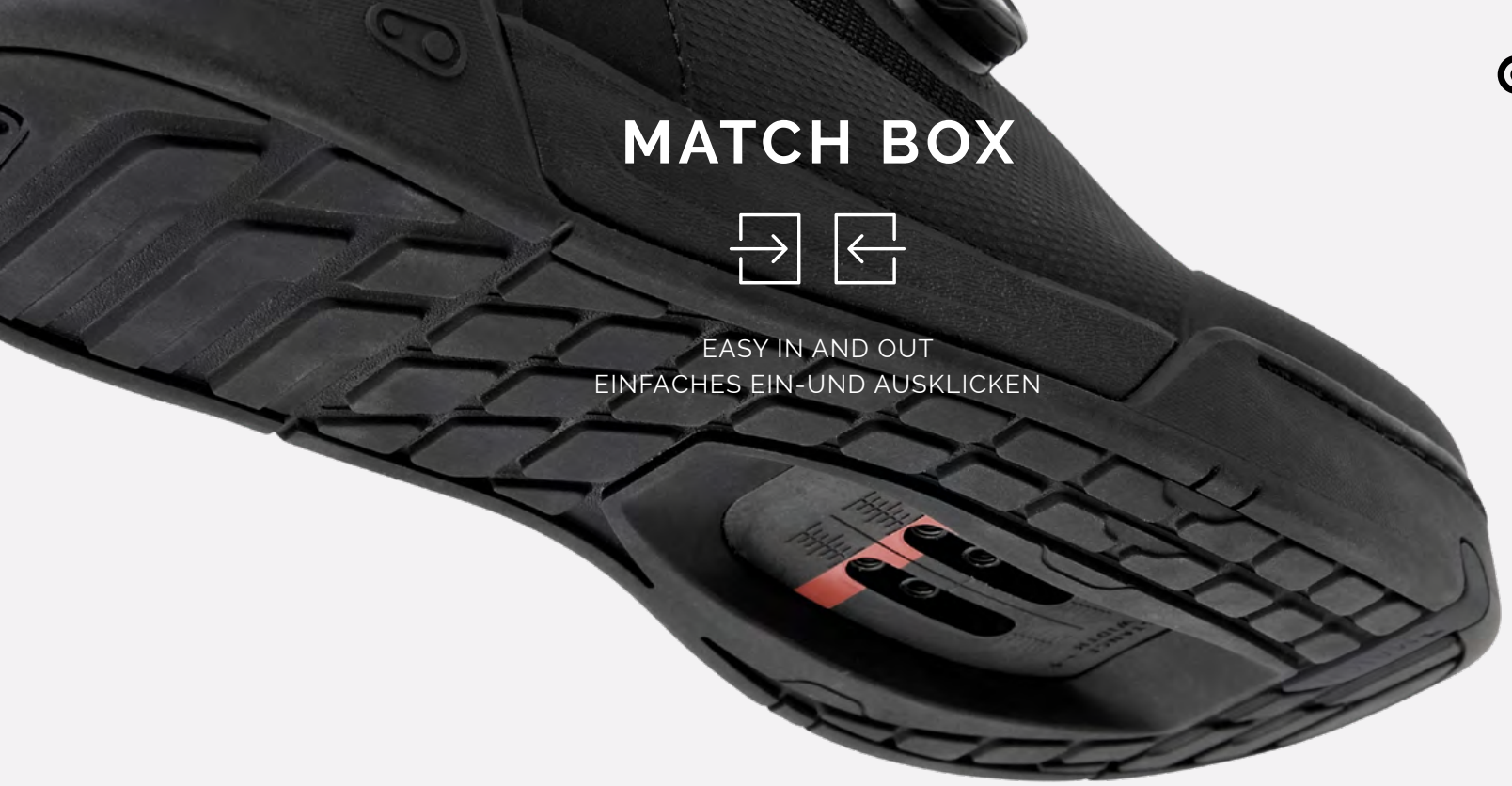

# READY TO RIDE



IMPROVING CUSTOMER EXPERIENCE  
THE CLEAT IS PRE-INSTALLED IN A NEUTRAL POSITION ON ALL CLIP-IN SHOES,  
EXCEPT FOR THE CANDY MODEL

VERBESSERUNG DES KUNDENERLEBNISSES  
DIE CLEATS SIND BEI ALLEN KLICKSCHUHEN, AUSSER DEM CANDY-MODELL,  
IN EINER NEUTRALEN POSITION VORINSTALLIERT

# TRAIL SHOES RANGE

## FEATURES UPPER | MERKMALE OBERSEITE

### BOA SYSTEM AND STRAP



## CLIP-IN OUTSOLE

### MATCH OUTSOLE

- Tread pattern designed for traction off the bike
- Directionally angled and spaced toe and heel lugs offer traction for hiking up or down steep terrain
- Ramped toe for better walkability
- Stiff fiber-reinforced nylon shank for power transfer
- Wrapped rubber front for extra toe protection

- Laufflächenmuster für Traktion abseits des Fahrrads entwickelt
- Richtungsweise abgewinkelte und voneinander beabstandete Zehen- und Fersenstollen bieten Traktion beim Wandern auf steilem Gelände
- Schräge Zehenkappe für bessere Gehfähigkeit
- Steifer, faser-verstärkter Nylon-Schaft für Kraftübertragung
- Gummiummantelter Vorderbereich für zusätzlichen Zehenschutz

### MATCH COMPOUND

- Mid-friction mc1 rubber compound allows for easy pedal entry and exit
- Enhanced wear and tear resistance
- Rounded lugs for abrasion resistance

- Mittelfrictions-Gummimischung (mc1) ermöglicht einfaches Ein- und Aussteigen aus dem Pedal
- Verbesserte Abriebfestigkeit
- Abgerundete Stollen für Abriebfestigkeit





## FEATURES UPPER | MERKMALE OBERSEITE

### LACE UP



## FLAT OUTSOLE



### MATCH OUTSOLE

- Deep, consistently placed lugs are designed for securing pins
- Directionally angled and spaced toe and heel lugs offer traction for hiking up or down steep terrain
- Tread pattern designed for traction off the bike
- Ramped toe provides better walkability
- Eva midsole for vibration dampening
- Wrapped rubber front for extra toe protection
- Tief und gleichmäßig platzierte Stollen sind entwickelt, um Pins zu sichern
- In Richtung und Abstand gewinkelte Stollen an Vorfuß und Ferse bieten Halt beim Wandern auf steilem Gelände
- Laufflächenmuster für guten Halt abseits des Fahrrads
- Abgeschrägte Spitze für bessere Gehfähigkeit
- EVA-Zwischensohle für Vibrationsdämpfung
- Gummiüberzug an der Vorderseite für zusätzlichen Zehenschutz

### MATCH COMPOUND

- Match compound optimized for grip and durability
- It has high-friction to stick to the pedal body and low rebound properties to damp vibrations
- Lugs are rounded to resist abrasion
- Speziell auf Haftung und Haltbarkeit optimierte Gummimischung
- Hoher Reibungskoeffizient, für den Halt an der Pedaloberfläche, und geringe Rückpralleigenschaften zur Vibrationsdämpfung.
- Abgerundete Stollen, um Abrieb zu vermeiden

CLIP-IN SHOES  
**MALLET TRAIL BOA**

**NEW**



**MALLET TRAIL LACE**

**NEW**



ARTICLE	NEW	MODEL	STYLE	COLOR	OUSOLE	CLOSURE	SIZE	WEIGHT	PRICE (€)
MTB41080A	<b>NEW</b>	<b>mallet trail boa</b>	clip-in	black/gold	gum	boa + strap	37-49	410g (single - size 42)	220
MTL41010A	<b>NEW</b>			black/black	gum				170
MTL42095A	<b>NEW</b>	<b>mallet trail lace</b>	clip-in	white/purple	purple	lace	37-49	385g (single - size 42)	170
MTL44040A	<b>NEW</b>			blue/blue	gum				170

All models are available in full sizes | Alle Modelle sind in ganzen Größe erhältlich



FLAT SHOES

## STAMP TRAIL BOA

NEW



## STAMP TRAIL LACE

NEW



ARTICLE	NEW	MODEL	STYLE	COLOR	OUSOLE	CLOSURE	SIZE	WEIGHT	PRICE (€)
TRB41080A	NEW	stamp trail boa	flat	black/gold	gum	boa + strap	37-49	320g (single - size 42)	200
TRL41010A	NEW			black/black	gum				150
TRL42095A	NEW	stamp trail lace	flat	white/purple	purple	lace	35-49	295g (single - size 42)	150
TRL44040A	NEW			blue/blue	gum				150

All models are available in full sizes | Alle Modelle sind in ganzen Größe erhältlich



# MALLET, MALLET E, STAMP RANGE

## FEATURES UPPER | MERKMALE OBERSEITE

### LACE UP

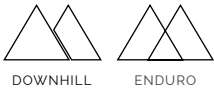

## PREMIUM MATERIALS HOCHWERTIGE MATERIALIEN

### BREATHABILITY/ATMUNGSAKTIV

Perforated materials and ventilated mesh windows provide breathability.  
Das perforierte Material und die luftdurchlässigen Mesh Fenster garantieren eine gute Atmungsaktivität.

### PROTECTION/SCHÜTZEND

Reinforced materials in the toe box provide protection against impacts.  
Die Zehenbox ist mit verstärktem Material ausgestattet, um Stöße und Schläge abzuwehren.

### COMFORT/KOMFORTABEL

Padded tongue and heel dots provide all-day comfort and superior fit.  
Die gepolsterte Zunge und Ferse gewährleisten ganztägigen Komfort und eine hervorragende Passform.



## THREE CLOSURE OPTIONS DREI VERSCHLUSSVARIANTEN

### BOA® SYSTEM & STRAP

A micro-adjustment dial, a strong lightweight lace and low-friction lace guides to deliver fast, effortless, precision fit. Designed to allow changes regardless of conditions, BOA® ensures you'll have instant control over your ride with a simple one-handed, on-the-fly adjustment.

Ein Mikro-Einstellrad, ein robustes, leichtes Schnürsystem und reibungsarme Schnürsenkelführungen sorgen für eine einfache, unkomplizierte und präzise Passform. Das BOA®-System wurde entwickelt, um Anpassungen unabhängig von den Gegebenheiten zu ermöglichen, so dass Sie jederzeit Einfluss auf die Passform nehmen können - mit einer simplen, auch während der Fahrt einhändig zu bedienenden Verstellmöglichkeit.



### SPEED LACE & STRAP

Speed lace closure system offers fast adjustment, a strap for secure closure and a pocket to safely tuck laces.

Das Speed Lace Closure System bietet eine schnelle Anpassungsfähigkeit, einen Riemen für festen Halt und eine Tasche zum sicheren Verstauen der Schnürsenkel.



### LACE UP

Classic lace closure system offers smooth closure with round laces and a pocket to safely tuck laces.

Das klassische Schnürverschluss-System ermöglicht ein reibungsloses Schnüren dank runder Schnürsenkel und einer Einschubtasche zum sicheren Verstauen der Schnürsenkel.



CLIP-IN SHOES  
**MALLET BOA**



CLIP-IN SHOES  
**MALLET SPEEDLACE**





CLIP-IN SHOES  
**MALLET LACE**



**PUMPFORPEACE EDITION**



**SPLATTER EDITION**



**SPLATTER EDITION**

ARTICLE	MODEL	STYLE	COLOR	OUSOLE	CLOSURE	SIZE	WEIGHT	PRICE (€)
MAB01080A	<b>mallet boa</b>	clip-in	black/gold	black	boa + strap	37-49	429g (single - size 42)	200
MAS01020A	<b>mallet speedlace</b>	clip-in	black/white	black	speedlace + strap	37-48	428g (single - size 42)	170
MAL01030A	<b>mallet lace</b>	clip-in	black/red	black	lace	37-48	415g (single - size 42)	150
MAL13010A	<b>mallet lace pumpforpeace edition</b>	clip-in	red/black*	gum	lace	37-48	415g (single - size 42)	160
MAL17040S	<b>mallet lace splatter edition</b>	clip-in	grey/blue*	gum	lace	37-48	415g (single - size 42)	150
MAL15152S	<b>mallet lace splatter edition</b>	clip-in	petrol/lime*	gum	lace	37-48	415g (single - size 42)	150

All models are available in full sizes | Alle Modelle sind in ganzen Größe erhältlich

(\*\*) Until sold out | Solange der Vorrat reicht

CLIP-IN SHOES  
**MALLET E BOA**



CLIP-IN SHOES  
**MALLET E SPEEDLACE**





CLIP-IN SHOES  
**MALLET E LACE**



ARTICLE	MODEL	STYLE	COLOR	OUSOLE	CLOSURE	SIZE	WEIGHT	PRICE (€)
MEB01080A	<b>mallet e boa</b>	clip-in	black/gold*	black	boa + strap	37-48	439g (single - size 42)	200
MES05443A	<b>mallet e speedlace</b>	clip-in	green/blue*	gum	speedlace + strap	37-48	437g (single - size 42)	170
MEL01043A	<b>mallet e lace</b>	clip-in	black/blue*	black	lace	37-48	432g (single - size 42)	150

All models are available in full sizes | Alle Modelle sind in ganzen Größe erhältlich

(\*\*) Until sold out | Solange der Vorrat reicht

FLAT SHOES  
STAMP BOA



FLAT SHOES  
STAMP SPEEDLACE





FLAT SHOES  
STAMP LACE



PUMPFORPEACE EDITION



SPLATTER EDITION



SPLATTER EDITION

ARTICLE	MODEL	STYLE	COLOR	OUSOLE	CLOSURE	SIZE	WEIGHT	PRICE (€)
STB01080A	<b>stamp boa</b>	flat	black/gold	black	boa + strap	37-49	379g (single - size 42)	180
STS21020A			black/white	black				150
STS29546A	<b>stamp speedlace</b>	flat	purple/teal blue	gum	speedlace + strap	37-48	383g (single - size 42)	150
STS05435A			green/orange*	black				150
STS07030A			grey/red*	black				150
STL04281A			black/silver			35-48		130
STL02086A	<b>stamp lace</b>	flat	white/white	gum	lace	35-48	376g (single - size 42)	130
STL01081A			navy/silver			37-49		130
STL13010P	<b>stamp lace pumpforpace edition</b>	flat	red/black*	gum	lace	37-48	376g (single - size 42)	140
STL17040S	<b>stamp lace splatter edition</b>	flat	grey/blue*	gum	lace	37-48	376g (single - size 42)	130
STL15152S			petrol/lime*					130

All models are available in full sizes | Alle Modelle sind in ganzen Größe erhältlich

(\*\*) Until sold out | Solange der Vorrat reicht



FLAT SHOES  
**STAMP STREET LACE**



ARTICLE	MODEL	STYLE	COLOR	OSOLE	CLOSURE	SIZE	WEIGHT	PRICE (€)
SSL11080F	<b>stamp</b>	flat	black/gold	gum	lace	35-48	570g (single - size 42)	130
SSL12080F	<b>street lace</b>		white/gold					130

All models are available in full sizes | Alle Modelle sind in ganzen Größe erhältlich



# CANDY GRAVEL / XC SHOE

## FEATURES UPPER | MERKMALE OBERSEITE

### LACE UP

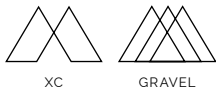

## CLIP-IN OUTSOLE

### MATCH OUTSOLE

- Full-rubber outsole and tread pattern is designed for traction off the bike
- Long central channel for uninterrupted pedal entry and mud shedding
- Ability to choose optimal cleat position with an extended 35mm cleat track
- Anti-slip zone if you don't engage on the pedal
- Gummisohle und Laufflächenmuster sind für Traktion abseits des Fahrrads ausgelegt
- Lange zentrale Rinne für unterbrechungsfreies Einklicken in das Pedal und Abschütteln von Schlamm
- Möglichkeit, die optimale Cleat-Position mit einer erweiterten 35-mm-Cleat-Schiene zu wählen
- Anti-Rutsch-Zone, falls kein Kontakt zum Pedal besteht

### MATCH COMPOUND

- Mid-friction mc1 rubber compound allows for easy pedal entry and exit
- Enhanced wear and tear resistance
- Rounded lugs to resist abrasion
- Mittelfrictions-Gummimischung (mc1) ermöglicht einfaches Ein- und Ausklicken aus dem Pedal
- Verbesserte Abriebfestigkeit
- Abgerundete Stollen für Abriebfestigkeit





CLIP-IN SHOES

# CANDY GRAVEL / XC LACE

**NEW**



ARTICLE	NEW	MODEL	STYLE	COLOR	OUSOLE	CLOSURE	SIZE	WEIGHT	PRICE (€)
CGL41010A	<b>NEW</b>	<b>candy gravel/xc lace</b>	clip-in	black/black	gum	lace	37-49	340g (single - size 42)	160
CGL42070A	<b>NEW</b>			white/grey	grey				160

All models are available in full sizes | Alle Modelle sind in ganzen Größe erhältlich

SOCKS  
**ICON MTB SOCKS**



WHITE / PURPLE



WHITE / RED / BLACK



BLACK / GOLD / GREY



BLACK / RED / GREY



WHITE / BROWN / BLACK



BLUE / WHITE

ARTICLE	UPC	NEW	MODEL	COLOR	SIZE	PRICE (€)
81333	641300813336	<b>NEW</b>	icon mtb sock	white/purple	small/medium	19,90
81334	641300813343	<b>NEW</b>		white/purple	large/x-large	19,90
81254	641300812544	<b>NEW</b>		white/red/black	small/medium	15,90
81255	641300812551	<b>NEW</b>		white/red/black	large/x-large	15,90
81223	641300812230			black/gold/grey	small/medium	15,90
81224	641300812247			black/gold/grey	large/x-large	15,90
81232	641300812322			black/red/grey*	small/medium	15,90
81230	641300812308			white/brown/black	small/medium	15,90
81231	641300812315			white/brown/black	large/x-large	15,90
81228	641300812285			navy blue/white	small/medium	15,90
81229	641300812292			navy blue/white	large/x-large	15,90

(\*\*) Until sold out | Solange der Vorrat reicht



LACES

BOA REPLACEMENT KIT

NEW



SPEEDLACE

NEW



PINK



BLACK



RED



ORANGE



LIGHT BLUE



WHITE



SILVER

ARTICLE	UPC	NEW	MODEL	COLOR	SIZE	PRICE (€)
16751	641300167514	NEW	BOA Li2 replacement kit	black	TU	30,00
16638	641300166388		BOA L6 replacement kit	black	TU	22,00
16738	641300167385	NEW	speedlace	pink	TU	10,90
16639	641300166395			black	TU	10,90
16640	641300166401			red	TU	10,90
16641	641300166418			orange	TU	10,90
16642	641300166425			light blue	TU	10,90
16643	641300166432			white	TU	10,90
16644	641300166449			silver	TU	10,90

LACES  
**ROUNDED LACE**

**NEW**



PINK



BLACK



RED



ORANGE



LIGHT BLUE



WHITE



SILVER

ARTICLE	UPC	NEW	MODEL	COLOR	SIZE	PRICE (€)
16736	641300167361	<b>NEW</b>	<b>rounded lace</b>	pink	small/medium	5,90
16737	641300167378	<b>NEW</b>			large/x-large	5,90
16645	641300166456			black	small/medium	5,90
16657	641300166579				large/x-large	5,90
16646	641300166463			red	small/medium	5,90
16658	641300166586				large/x-large	5,90
16647	641300166470			orange	small/medium	5,90
16659	641300166593				large/x-large	5,90
16648	641300166487			light blue	small/medium	5,90
16660	641300166609				large/x-large	5,90
16649	641300166494			white	small/medium	5,90
16661	641300166616				large/x-large	5,90
16650	641300166500			silver	small/medium	5,90
16662	641300166623				large/x-large	5,90



LACES  
**FLAT LACE**

**NEW**



BLACK



WHITE



SAGE GREEN



SILVER



ORANGE



BLUE



PINK

ARTICLE	UPC	NEW	MODEL	COLOR	SIZE	PRICE (€)
16729	641300167293	<b>NEW</b>	flat lace	black	small/medium	5,90
16739	641300167392	<b>NEW</b>			large/x-large	5,90
16730	641300167309	<b>NEW</b>		white	small/medium	5,90
16740	641300167408	<b>NEW</b>			large/x-large	5,90
16731	641300167316	<b>NEW</b>		sage green	small/medium	5,90
16741	641300167415	<b>NEW</b>			large/x-large	5,90
16732	641300167323	<b>NEW</b>		silver	small/medium	5,90
16742	641300167422	<b>NEW</b>			large/x-large	5,90
16733	641300167330	<b>NEW</b>		orange	small/medium	5,90
16743	641300167439	<b>NEW</b>			large/x-large	5,90
16734	641300167347	<b>NEW</b>		blue	small/medium	5,90
16744	641300167446	<b>NEW</b>			large/x-large	5,90
16735	641300167354	<b>NEW</b>		pink	small/medium	5,90
16745	641300167453	<b>NEW</b>			large/x-large	5,90





WHEELS

# SYNTHESIS

TUNED WHEEL  
SYSTEM

SYNTHESIS CARBON WHEELS FEATURE A LIFETIME WARRANTY.  
DETAILS AT [CRANKBROTHERS.COM](https://www.crankbrothers.com)

SYNTHESIS-CARBON-LAUFRÄDER BEIHALTEN EINE LEBENSLANGE GARANTIE.  
DETAILS UNTER [CRANKBROTHERS.COM](https://www.crankbrothers.com)



FRONT AND REAR SPECIFIC | VORDER-UND HINTERRAD SPEZIFISCH

## TUNED WHEEL SYSTEM ABGESTIMMTES LAUFRAD-SYSTEM

### FRONT MATRIX

- Reduced spoke count
- Lower spoke tension
- Lighter weight spoke
- Wider inner rim width
- Lighter rim

### VORDERSEITE MATRIX

- Reduzierte Speichenanzahl
- Geringere Speichenspannung
- Leichtere Speichen
- Breiteres Felgeninnenmaß
- Leichtere Felge

### REAR MATRIX

- Higher spoke count
- Higher spoke tension
- Increased weight spoke
- Narrower inner rim width
- Tougher rim

### HINTERRAD MATRIX

- Höhere Speichenanzahl
- Höhere Speichenspannung
- Schwerere Speichen
- Schmaleres Felgeninnenmaß
- Robustere Felge

CONTROL IN TURNS | KONTROLLE IN KURVEN

## COMPLIANT FRONT WHEEL NACHGIEBIGES VORDERRAD



### OPTIMIZE HANDLING

- Reduce trail chatter
- Reduced rider fatigue
- Deflects and absorbs energy

### VERBESSERTES HANDLING

- Reduziertes "trail chatter"
- Reduziert ermüden des Fahrers
- Nimmt Energie auf und leitet diese um



### MAINTAIN CONTACT PATCH

- Improved grip
- Improved turning at speed
- Keeps tire connected to trail

### MAINTAIN CONTACT PATCH

- Verbesserter Grip
- Verbessertes Kurvenverhalten
- Hält die Verbindung zwischen Reifen und Trail



### WIDER INNER RIM WIDTH

- Increase tire volume for better contact
- Round tire profile to enhance turning
- Support wider tire profile in front

### BREITERES FELGENINNENMASS

- Verbessert das Reifenvolumen für mehr Kontaktfläche
- Runderes Reifenprofil für einfacheres Kurvenfahren
- Unterstützt breitere Reifenprofile an der Front

STABILITY AND TRACKING AT SPEED | STABILITÄT UND SPURTREUE BEI GESCHWINDIGKEIT

## STIFF REAR WHEEL STEIFES HINTERRAD

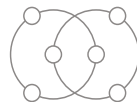

### DIRECTIONAL/RADIAL LOADS SUPPORTED CORRECTLY

- Responsiveness
- Maintain speed and momentum
- Stability
- Support peak loads
- Anchor riders center of gravity

### DIREKTIONALE/RADIALE BELASTUNGEN RICHTIG UNTERSTÜTZT

- Reaktionsfreudig
- Geschwindigkeit und Momentum werden beibehalten
- Stabilität
- Unterstützt bei Spitzenlasten
- Festigt den Fahrerswerpunkt



### NARROWER INNER RIM WIDTH

- Reduce contact patch
- Improve rolling resistance
- Harden tire profiles edge for grip

### SCHMALERES FELGENINNENMASS

- Reduzierte Kontaktfläche
- Geringerer Rollwiderstand
- Verstärkt das äußere Reifenprofil für mehr Grip

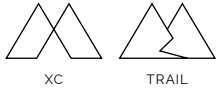

# CARBON WHEELSETS

## SYNTHESIS XCT 11

PRECISE HANDLING AT FULL SPEED

### HUB

SYNTHESIS 11 (INDUSTRY NINE HYDRA HUB)

### ENGAGEMENT

0.52" QUICK ENGAGEMENT / SIX PAWLS

### SPOKES

SAPIM CX-RAY (FRONT)

SAPIM CX-RAY (REAR)



FRONT



REAR

#### COMPLIANT FRONT WHEEL

SPOKE COUNT: 28  
INNER RIM WIDTH: 26.5

#### STIFF REAR WHEEL

SPOKE COUNT: 32  
INNER RIM WIDTH: 24.5

#### OUTER RIM WIDTH

OUTER RIM WIDTH FRONT: 31.1 MM  
REAR: 29.5 MM

ARTICLE	UPC	MODEL	DIAMETER	HUB	DRIVER BODY	FRONT AXLE	REAR AXLE	RIM	WEIGHT	PRICE (€)
16299	641300162991	synthesis xct 11	29"	boost i9	xd	110x15 mm	148x12 mm	carbon premium	1519g	2400
16464	641300164643		29"	boost i9	shimano micro spline	110x15 mm	148x12 mm	carbon premium	1764g	2400

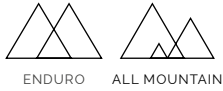

CARBON WHEELSETS  
**SYNTHESIS E 11**

CONTROL & STABILITY FOR ENDURO RIDING

**HUB**  
 INDUSTRY NINE HYDRA HUB

**ENGAGEMENT**  
 0.52" QUICK ENGAGEMENT / SIX PAWLS

**SPOKES**  
 SAPIM CX-RAY (FRONT)  
 SAPIM CX-SPRINT (REAR)



FRONT



REAR

COMPLIANT FRONT WHEEL

SPOKE COUNT: 28  
 INNER RIM WIDTH: 31.5

STIFF REAR WHEEL

SPOKE COUNT: 32  
 INNER RIM WIDTH: 29.5

OUTER RIM WIDTH

OUTER RIM WIDTH FRONT: 37.5 MM  
 OUTER RIM WIDTH REAR: 36.5 MM

ARTICLE	UPC	MODEL	DIAMETER	HUB	DRIVER BODY	FRONT AXLE	REAR AXLE	RIM	WEIGHT	PRICE (€)
16448	641300164483	synthesis e 11	27.5"	boost i9	shimano micro spline	110x15 mm	148x12 mm	carbon premium	1760g	2400
16449	641300164490		27.5"	super boost 157 i9	xd	110x15 mm	157x12mm	carbon premium	1760g	2400
16454	641300164544		29"	boost i9	shimano micro spline	110x15 mm	148x12 mm	carbon premium	1825g	2400
16455	641300164551		29"	super boost 157 i9	xd	110x15 mm	157x12mm	carbon premium	1825g	2400
16446	641300164469		27.5"	boost i9	xd	110x15 mm	148x12 mm	carbon premium	1760g	2400
16452	641300164520		29"	boost i9	xd	110x15 mm	148x12 mm	carbon premium	1825g	2400



# CARBON SINGLE WHEEL SYNTHESIS GRAVEL CARBON

**NEW**

WHERE COMFORT MEETS PERFORMANCE

**HUB**  
SYNTHESIS RATCHET

**ENGAGEMENT**  
10°

**SPOKES**  
SAPIM D-LIGHT

**SIZES**  
700 C / 650 B

**WEIGHT**  
700 C: 1544g / 650 B: 1517G

TUBELESS READY



FRONT

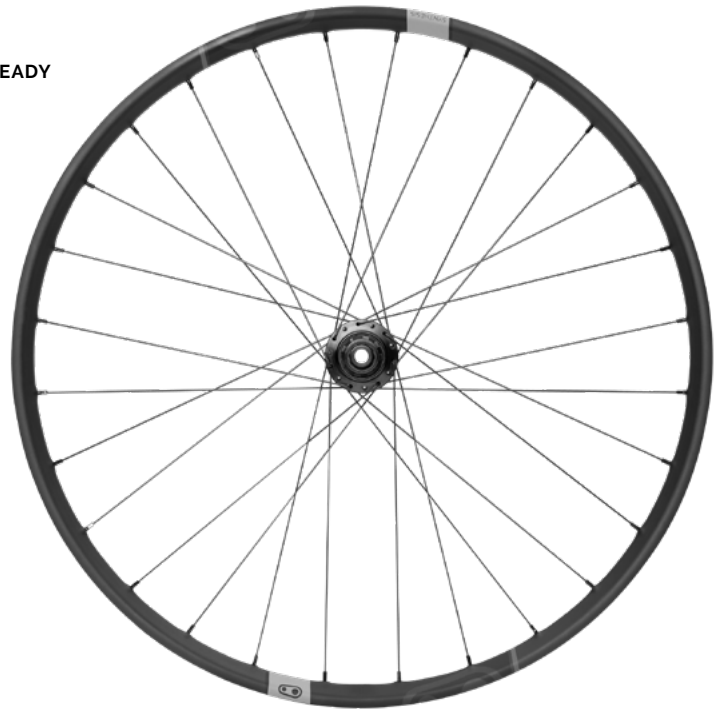

REAR

FRONT WHEEL

SPOKE COUNT: 28  
INNER RIM WIDTH: 26.5

REAR WHEEL

SPOKE COUNT: 28  
INNER RIM WIDTH: 26.5

ARTICLE	UPC	NEW	MODEL	DIAMETER	HUB	DRIVER BODY	FRONT AXLE	REAR AXLE	RIM	WEIGHT	PRICE (€)
16825	641300168252	<b>NEW</b>	synthesis gravel carbon	<b>700c front</b>	CB ratchet	-	12X100 mm	-	26.5mm	716g	600
16826	641300168269	<b>NEW</b>		<b>700c rear</b>	CB ratchet	XDR	-	142x12 mm	26.5mm	833g	900
16827	641300168276	<b>NEW</b>		<b>700c rear</b>	CB ratchet	HG	-	142x12 mm	26.5mm	836g	900
16828	641300168283	<b>NEW</b>		<b>650b front</b>	CB ratchet	-	12X100 mm	-	26.5mm	698g	600
16829	641300168290	<b>NEW</b>		<b>650b rear</b>	CB ratchet	XDR	-	142x12 mm	26.5mm	819g	900
16830	641300168306	<b>NEW</b>		<b>650b rear</b>	CB ratchet	HG	-	142x12 mm	26.5mm	826g	900



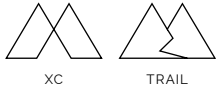

# ALLOY SINGLE WHEEL SYNTHESIS XCT ALLOY

PRECISE HANDLING AT FULL SPEED

**HUB**  
SYNTHESIS STANDARD HUB

**ENGAGEMENT**  
4'

**SPOKES**  
SAPIM D-LIGHT (FRONT)  
SAPIM RACE (REAR)



FRONT



REAR

COMPLIANT FRONT WHEEL

SPOKE COUNT: 28    INNER RIM WIDTH: 26.5

STIFF REAR WHEEL

SPOKE COUNT: 32    INNER RIM WIDTH: 24.5

ARTICLE	UPC	MODEL	DIAMETER	DRIVER BODY	HUB	FRONT AXLE	REAR AXLE	RIM	WEIGHT	PRICE (€)
16418	641300164186	synthesis alloy xct	29" front	-	boost	110x15 mm	148x12 mm	aluminum	841g	240
16419	641300164193		29" rear	xd	boost	110x15 mm	148x12 mm	aluminum	998g	360
16421	641300164216		29" rear	shimano micro spline	boost	110x15 mm	148x12 mm	aluminum	998g	360



ALLOY SINGLE WHEEL  
**SYNTHESIS E ALLOY**

CONTROL & STABILITY FOR ENDURO RIDING

**HUB**  
 SYNTHESIS STANDARD HUB

**ENGAGEMENT**  
 4°  
 17°

**SPOKES**  
 SAPIM D-LIGHT (FRONT)  
 SAPIM RACE (REAR)



FRONT



REAR

COMPLIANT FRONT WHEEL

SPOKE COUNT: 28    INNER RIM WIDTH: 31.5

STIFF REAR WHEEL

SPOKE COUNT: 32    INNER RIM WIDTH: 29.5

ARTICLE	UPC	MODEL	DIAMETER	DRIVER BODY	HUB	FRONT AXLE	REAR AXLE	RIM	WEIGHT	PRICE (€)
16406	641300164063	synthesis alloy enduro	27.5" front	-	boost	110x15 mm	148x12 mm	aluminum	877g	240
16407	641300164070		27.5" rear	xd	boost	110x15 mm	148x12 mm	aluminum	1062g	360
16409	641300164094		27.5" rear	shimano micro spline	boost	110x15 mm	148x12 mm	aluminum	1062g	360
16410	641300164100		29" front	-	boost	110x15 mm	148x12 mm	aluminum	902g	240
16411	641300164117		29" rear	xd	boost	110x15 mm	148x12 mm	aluminum	1095g	360
16413	641300164131		29" rear	shimano micro spline	boost	110x15 mm	148x12 mm	aluminum	1095g	360





# ALLOY SINGLE WHEEL SYNTHESIS E-BIKE ALLOY

BUILT FOR E-MTB

## HUB

SYNTHESIS STANDARD HUB

## ENGAGEMENT

17'

## SPOKES

S APIM E-LIGHT (FRONT)

S APIM STRONG (REAR)



FRONT



REAR

SIZES: 27.5 - 29

SIZE: 27.5+

COMPLIANT FRONT WHEEL

STIFF REAR WHEEL

COMPLIANT FRONT WHEEL

STIFF REAR WHEEL

SPOKE COUNT:  
28

INNER RIM  
WIDTH:  
31.5

SPOKE COUNT:  
32

INNER RIM  
WIDTH:  
31.5

SPOKE COUNT:  
28

INNER RIM  
WIDTH:  
35.5

SPOKE COUNT:  
32

INNER RIM  
WIDTH:  
35.5

ARTICLE	UPC	MODEL	DIAMETER	DRIVER BODY	HUB	FRONT AXLE	REAR AXLE	RIM	WEIGHT	PRICE (€)
16422	641300164223	synthesis alloy e-mtb	<b>27.5" plus/front</b>	-	boost	110x15 mm	148x12 mm	aluminum	928g	300
16423	641300164230		<b>27.5" plus/rear</b>	xd	boost	110x15 mm	148x12 mm	aluminum	1181g	400
16425	641300164254		<b>27.5" plus/rear</b>	shimano micro spline	boost	110x15 mm	148x12 mm	aluminum	1181g	400
16426	641300164261		<b>29" front</b>	-	boost	110x15 mm	148x12 mm	aluminum	980g	300
16427	641300164278		<b>29" rear</b>	xd	boost	110x15 mm	148x12 mm	aluminum	1238g	400
16429	641300164292		<b>29" rear</b>	shimano micro spline	boost	110x15 mm	148x12 mm	aluminum	1238g	400



ALLOY SINGLE WHEEL  
**SYNTHESIS GRAVEL ALLOY**

**NEW**

WHERE COMFORT MEETS PERFORMANCE

**HUB**  
 SYNTHESIS STANDARD

**ENGAGEMENT**  
 17°

**SPOKES**  
 SAPIM D-LIGHT

**SIZES**  
 700 C / 650 B

**WEIGHT**  
 700 C: 1917g / 650 B: 1769g

TUBELESS READY

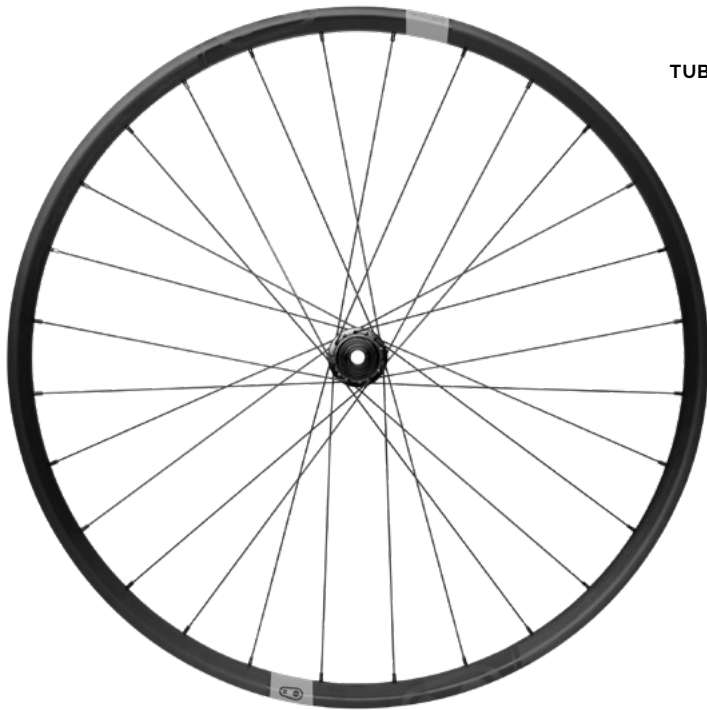

FRONT



REAR

FRONT WHEEL

SPOKE COUNT: 28    INNER RIM WIDTH: 26.5

REAR WHEEL

SPOKE COUNT: 28    INNER RIM WIDTH: 26.5

ARTICLE	UPC	NEW	MODEL	DIAMETER	HUB	DRIVER BODY	FRONT AXLE	REAR AXLE	RIM	WEIGHT	PRICE (€)
16831	641300168313	NEW		<b>700c front</b>	CB ratchet	-	12X100 mm	-	26.5mm	869g	240
16832	641300168320	NEW		<b>700c rear</b>	CB ratchet	XDR	-	142X12 mm	26.5mm	1050g	360
16833	641300168337	NEW	synthesis alloy gravel	<b>700c rear</b>	CB ratchet	HG	-	142X12 mm	26.5mm	1058g	360
16834	641300168344	NEW		<b>650b front</b>	CB ratchet	-	12X100 mm	-	26.5mm	792g	240
16835	641300168351	NEW		<b>650b rear</b>	CB ratchet	XDR	-	142X12 mm	26.5mm	977g	360
16836	641300168368	NEW		<b>650b rear</b>	CB ratchet	HG	-	142X12 mm	26.5mm	985g	360

## FASTER TO ACCELERATE/DECELERATE SCHNELLERES BESCHLEUNIGEN/ABBREMSEN

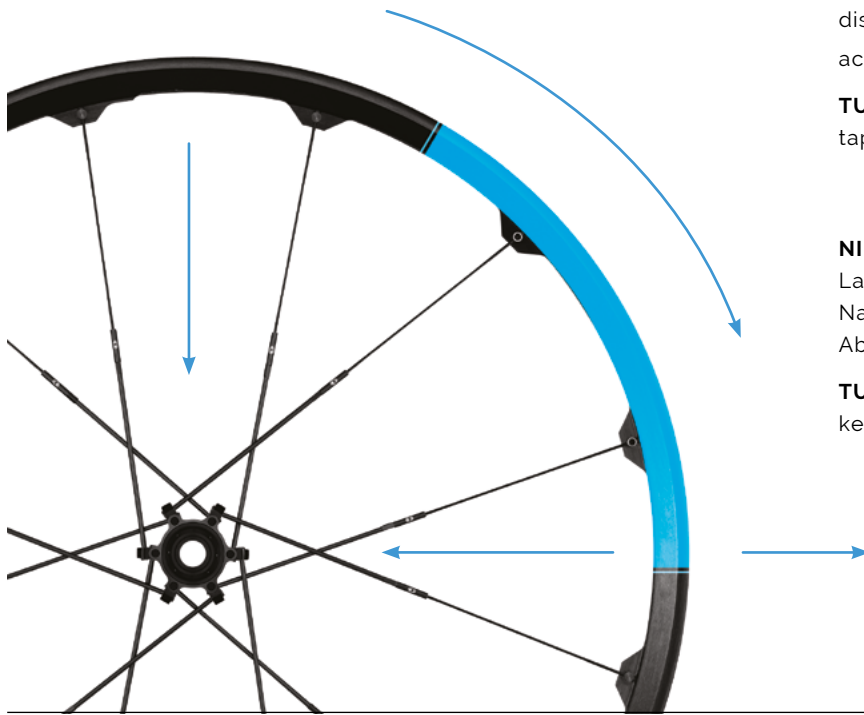

**LOW ROTATIONAL INERTIA.** Unique wheel design distributes mass closer to the hub for faster acceleration and deceleration.

**TUBELESS READY.** Hole-less rims: stronger and no rim tape required for tubeless setup.

**NIEDRIGE ROTATIONSTRÄGHEIT.** Das einzigartige Laufrad Design verteilt die Masse näher zum Nabenkörper für ein schnelleres Beschleunigen und Abbremsen.

**TUBELESS READY.** Lochlose Felge: stabiler und es wird kein Felgenband benötigt für ein Tubeless Setup.

## STRONGER AND STIFFER STABILER UND STEIFER

**TWINPAIR SPOKE TECHNOLOGY.** Designed using the strongest shape in construction, the triangle, to maximize strength and stiffness.

**BEAUTIFULLY SIMPLE.** Single spoke length: easy to true and replaceable without removing tire.

**TWINPAIR SPEICHEN TECHNOLOGIE.** Designed mit der stabilsten Form im Aufbau, dem Dreieck, für ein Maximum an Haltbarkeit und Steifigkeit.

**WUNDERBAR EINFACH.** Einheitliche Speichenlänge: einfaches zentrieren und austauschbar ohne den Reifen zu entfernen.

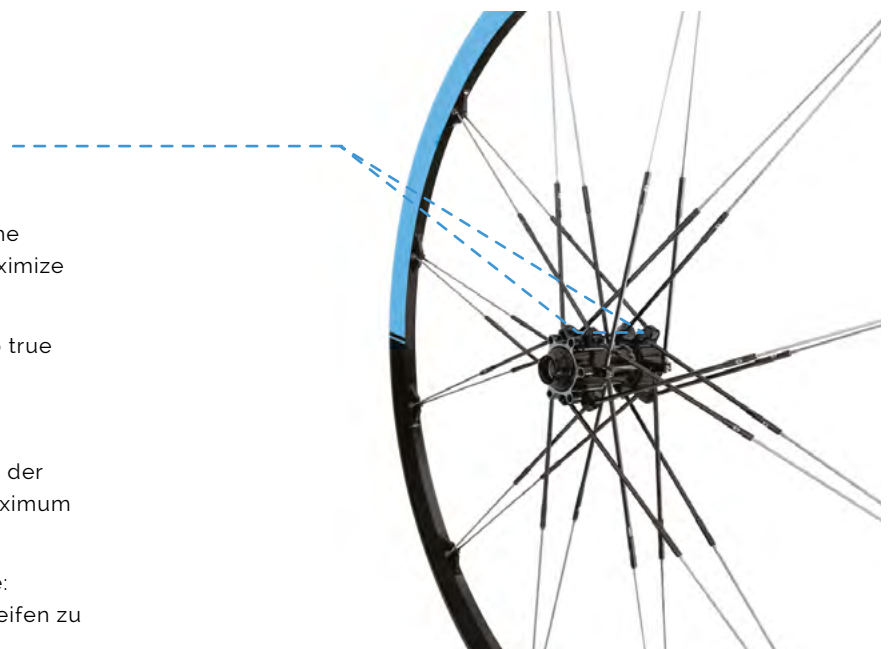

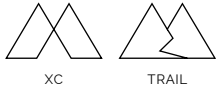

## ALLOY WHEELSETS

### COBALT

**2** COBALT 2  
ALUMINUM

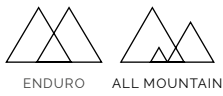
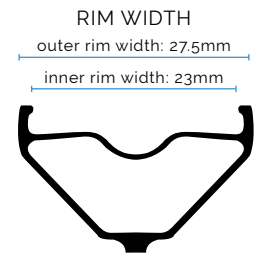

### IODINE

**2** IODINE 2  
ALUMINUM

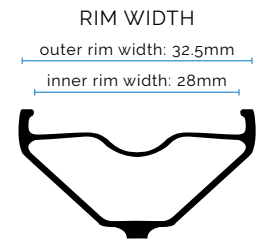

### ZINC

**3** ZINC 3  
ALUMINUM

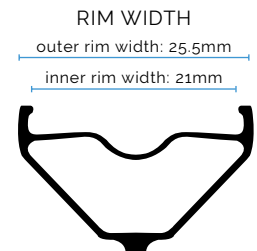

ARTICLE	UPC	MODEL	DIAMETER	HUB	DRIVER BODY	FRONT AXLE	REAR AXLE	COLOR	WEIGHT	PRICE (€)
16140	641300161406	<b>cobalt 2</b>	<b>29"</b>	standard	shimano hg	100x15 mm	142x12 mm	black/grey	1735g	600
16143	641300161437	<b>iodine 2</b>	<b>29"</b>	boost	-	110x15 mm	148x12 mm	black/grey	1900g	600
16145	641300161451		<b>27.5"</b>	boost	-	110x15 mm	148x12 mm	black/grey	1830g	600
16139	641300161390	<b>zinc 3</b>	<b>29"</b>	standard	shimano hg	100x15 mm	142x12 mm	black/white	1645g	800



## GRIPS COBALT

COBALT  
GRIPS

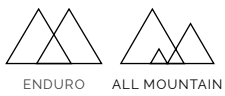

## IODINE

IODINE  
GRIP



ARTICLE	UPC	MODEL	COLOR	material	WIDTH	WEIGHT	PRICE (€)
15279	641300152794		silver				30
14918	641300149183	<b>cobalt grips</b>	gold	High density foam	130mm	67g	30
14919	641300149190		red				30
14920	641300149206	<b>iodine grip</b>	black	Krayton rubber	130mm	95g	30



## WHEELSETS ACCESSORIES



**XD DRIVER BODY**  
SYNTHESIS & ALLOY WHEELSETS



**WHEEL END CAP KIT (FRONT)**  
COBALT / IODINE / ZINC  
9mm



**WHEEL END CAP + AXLE KIT (FRONT)**  
COBALT / IODINE / ZINC  
100mm x 12mm



**WHEEL END CAP KIT (FRONT)**  
COBALT / IODINE / ZINC  
15mm



**WHEEL END CAP KIT (REAR)**  
COBALT / IODINE (LEVEL 3 & 11)  
135mm x 10mm



**WHEEL END CAP KIT (REAR)**  
COBALT / IODINE (LEVEL 3 & 11)  
142mm x 12mm

ARTICLE	UPC	COLLECTION	MODEL KIT	PRICE (€)
15538	641300155382	<b>wheelsets accessories</b>	wheel synthesis and alloy xd driver body for: level 2,3 e 11 (from range 2017)	100
99202	641300992024		wheel end cap kit for: cobalt / iodine / zinc > front 9mm	20
99203	641300992031		wheel end cap kit for: cobalt / iodine / zinc > front 15mm	20
99204	641300992048		wheel end cap kit for: cobalt / iodine level 3/11 > rear 135x10 mm	20
99205	641300992055		wheel end cap kit for: cobalt / iodine level 3/11 > rear 142x12 mm	20
99162	641300991621		wheel end cap + axle kit for: cobalt / iodine / zinc > front 100x12 mm	30



**DROPPER SEATPOST**

## **HIGHLINE DROPPER SEATPOST**

OUR LIGHTEST WEIGHT DROPPER POST WITH PREMIUM MATERIALS  
FOR WEIGHT SAVINGS.

UNSERE LEICHTESTE TELESKOPSATTELSTÜTZE AUS HOCHWERTIGEN MATERIALIEN  
FÜR GERINGERES GEWICHT.



## DROPPER SEATPOST

# HIGHLINE 11 DROPPER SEATPOST

PREMIUM TRELLEBORG SEALING, EXCLUSIVE IGUS BEARINGS & KEYS, JAGWIRE CABLE & A SELF CONTAINED HYDRAULIC CARTRIDGE DELIVER INDUSTRY LEADING QUALITY & RELIABILITY.

HOCHWERTIGE TRELLEBORG-DICHTUNGEN, SPEZIELLE IGUS LAGER UND KEILFEDERN, JAGWIRE-KABEL UND EINE IN SICH GESCHLOSSENE HYDRAULIKKARTUSCHE SORGEN FÜR EINE BRANCHENFÜHRENDE QUALITÄT UND ZUVERLÄSSIGKEIT.

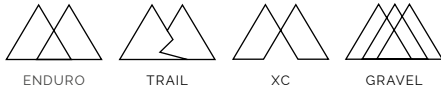

**HIGHLINE 11**  
100mm  
125mm  
150mm  
170mm

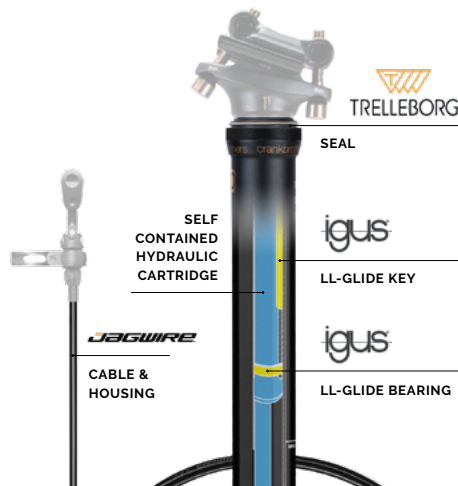

### PREMIUM COMPONENTS

- proprietary self contained IFP hydraulic cartridge on Highline 11 developed by CB for extremely smooth actuation
- proprietary Igus LL-glide bearings & keys to minimize play
- Jagwire cable & housing

### ERSTKLASSIGE KOMPONENTEN

- eigens von CB für die Highline 11 entwickelte, in sich geschlossene IFP-Hydraulikpatrone für extrem leichtgängige Ansteuerung
- eigene Igus LL-Gleitlager & Passfedern für minimales Spiel
- Jagwire Kabel & Hülle

### QUICK-SADDLE INSTALLATION SYSTEM



### HEAD FEATURES

- aluminium head
- titanium mounting bolts
- two-bolt quick release head for easy saddle installation, fore / aft, and tilt adjustments
- 47mm min stack height for full travel on smaller bikes

### EIGENSCHAFTEN DES KOPFES

- Aluminium-Kopf
- Befestigungsbolzen aus Titan
- Zwei-Schrauben-Schnellspannkopf für einfache Sattelmontage, Vorwärts- / Rückwärts- und Neigungsverstellung
- 47 mm Mindesteinbauhöhe für vollen Federweg bei kleineren Fahrrädern



**LINEAR PULL CABLE**

### ACTUATOR SYSTEM

- quick-connect linear pull mechanism offers ease of cable installation and routing
- this feature allows for lighter action and quicker return speed

### BETÄTIGUNGSSYSTEM

- Schnellkupplungs-Linearzugmechanismus bietet einfache Kabelinstallation und -verlegung
- Diese Funktion ermöglicht eine leichtere Bewegung und eine schnellere Rückföhrgeschwindigkeit

### FEATURES

- 100mm/125mm/150mm/170mm of infinite travel adjustment
- diameter: 30.9 & 31.6
- insertion lengths: see chart
- weights: see chart
- carbon quill
- aluminium head
- titanium mounting bolts
- industry leading 4 year warranty

### EIGENSCHAFTEN

- 100mm/125mm/150mm/170mm stufenlose Verstellwege
- Durchmesser: 30.9 & 31.6
- Einbaulängen: siehe Tabelle
- Gewichte: siehe Tabelle
- Carbon-Feder
- Aluminium-Kopf
- Montagebolzen aus Titan
- branchenführende Garantie über 4 Jahre



DROPPER SEATPOST

## HIGHLINE 7 & 3 DROPPER SEATPOST HIGHLINE 7 & 3 DROPPER-SATTELSTÜTZE

PREMIUM TRELLEBORG SEALING, EXCLUSIVE IGUS BEARINGS & KEYS, JAGWIRE CABLE & A SELF CONTAINED HYDRAULIC CARTRIDGE DELIVER INDUSTRY LEADING QUALITY & RELIABILITY.

HOCHWERTIGE TRELLEBORG-DICHTUNGEN, SPEZIELLE IGUS LAGER UND KEILFEDERN, JAGWIRE-KABEL UND EINE IN SICH GESCHLOSSENE HYDRAULIKKARTUSCHE SORGEN FÜR EINE BRANCHENFÜHRENDE QUALITÄT UND ZUVERLÄSSIGKEIT.



7

HIGHLINE 7  
100mm  
125mm  
150mm  
170mm  
200mm

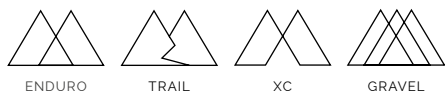

3

HIGHLINE 3  
80mm  
100mm  
125mm  
150mm  
170mm  
200mm





## DROPPER SEATPOST

# HIGHLINE XC/GRAVEL DROPPER SEATPOST HIGHLINE XC/GRAVEL DROPPER-SATTELSTÜTZE

NARROW DIAMETER DROPPER POST OFFERS SHORT TRAVEL OPTIONS FOR CROSS-COUNTRY AND GRAVEL BIKES.  
DIE DROPPER-SATTELSTÜTZE MIT REDUZIERTEM DURCHMESSER ERMÖGLICHT ANPASSUNGEN DER SATTELHÖHEN  
FÜR CROSS-COUNTRY UND GRAVEL-BIKES.

HIGHLINE XC/GRAVEL Ø 27,2mm  
60mm  
80mm  
100mm  
125mm



HYDRAULIC IFP CARTRIDGE



QUICK-CONNECT LINEAR  
PULL ACTUATOR



60mm MINIMUM STACK HEIGHT

### FEATURES

- 60mm short & long /80mm/100mm/125mm of infinite travel adjustment
- diameter: 27,2mm
- insertion lengths: 174mm short & 264mm long /264mm/264mm/264mm (bottom of collar to bottom of actuator)
- weights: 369g & 410g/434g/459g/467g
- quick-connect linear pull mechanism offers ease of cable installation and routing
- 60mm minimum stack height
- self-contained hydraulic IFP cartridge
- two-bolt standard head
- internal routing
- premium internals
- Jagwire® cable and housing
- remote sold separately
- 4 years warranty

### EIGENSCHAFTEN

- 60mm kurz & lang /80mm/100mm/125mm stufenlose Wegverstellung
- Durchmesser: 27,2mm
- Einbaulängen: 174mm kurz & 264 mm lang /264mm/264mm/264mm (Unterseite des Kragens bis Unterseite des Betätigungselementes)
- Gewichte: 369g & 410g/434g/459g/467g
- Schnellkupplungs-Linear-Zugmechanismus bietet einfache Kabelinstallation und -führung
- 60mm minimale Bauhöhe
- unabhängige hydraulische IFP-Patrone
- Zwei-Schrauben-Standardkopf
- interne Zugverlegung
- hochwertige interne Komponenten
- Jagwire®-Kabel und Gehäuse
- Fernbedienung separat erhältlich
- 4 Jahre Garantie

## DROPPER SEATPOST



HIGHLINE 11							
ARTICLE	UPC	MODEL	TRAVEL	DIAMETER	LENGTH	WEIGHT*	PRICE (€)
16481	641300164810	<b>highline 11*</b> (No remote lever included)	100mm	30.9	367mm	398g	€ 400
16482	641300164827			31.6		418g	€ 400
16483	641300164834		125mm	30.9	417mm	429g	€ 400
16484	641300164841			31.6		449g	€ 400
16485	641300164858		150mm	30.9	467mm	465g	€ 400
16486	641300164865			31.6		486g	€ 400
16487	641300164872		170mm	30.9	507mm	488g	€ 400
16488	641300164889			31.6		509g	€ 400



HIGHLINE 7							
ARTICLE	UPC	MODEL	TRAVEL	DIAMETER	LENGTH	WEIGHT*	PRICE (€)
16378	641300163783	<b>highline 7</b> (No remote lever included)	100mm	30.9	367mm	474g	300
16379	641300163790			31.6		490g	300
16380	641300163806		125mm	30.9	417mm	515g	300
16381	641300163813			31.6		525g	300
16382	641300163820		150mm	30.9	467mm	550g	300
16383	641300163837			31.6		572g	300
16384	641300163844		170mm	30.9	507mm	583g	300
16385	641300163851			31.6		604g	300
16621	641300166210	200mm	31.6	567mm	679g	300	

(\*) Weight includes post only. Housing adds 25-60 g based on length.

(\*) Gewicht bezieht sich nur auf die Stütze. Durch die Hülle werden je nach Länge 25-60 g hinzugefügt.



## DROPPER SEATPOST

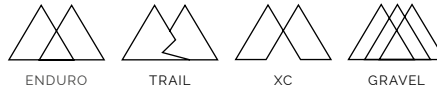

HIGHLINE 3							
ARTICLE	UPC	MODEL	TRAVEL	DIAMETER	LENGTH	WEIGHT*	PRICE (€)
16501	641300165015	<b>highline 3</b> (No remote lever included)	80mm	30.9	418mm	540g	200
16502	641300165022			31.6		564g	200
16370	641300163707		100mm	30.9	370mm	484g	200
16371	641300163714			31.6		503g	200
16469	641300164698		125mm	34.9	421mm	603g	200
16372	641300163721			30.9		525g	200
16373	641300163738		150mm	31.6	469mm	545g	200
16471	641300164711			34.9		645g	200
16374	641300163745		170mm	30.9	509mm	565g	200
16375	641300163752			31.6		587g	200
16472	641300164728		200mm	34.9	569mm	699g	200
16376	641300163769			30.9		585g	200
16377	641300163776		200mm	31.6	569mm	609g	200
16473	641300164735			34.9		735g	200
16523	641300165237					686g	200

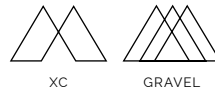

HIGHLINE XC/GRAVEL							
ARTICLE	UPC	MODEL	TRAVEL	DIAMETER	LENGTH	WEIGHT*	PRICE (€)
16489	641300164896	<b>highline xc/gravel</b> (No remote lever included)	60mm short	27.2	297mm	369g	250
16490	641300164902		60mm long	27.2	387mm	410g	250
16500	641300165008		80mm	27.2	407mm	434g	250
16468	641300164681		100mm	27.2	427mm	459g	250
16470	641300164704		125mm	27.2	452mm	467g	250

(\*) Weight includes post only. Housing adds 25-60 g based on length.

(\*) Gewicht bezieht sich nur auf die Stütze. Durch die Hülle werden je nach Länge 25-60 g hinzugefügt.

## HIGHLINE REMOTE KIT

# WORLD'S MOST ERGONOMIC REMOTE DER WELTWEIT ERGONOMISCHSTE REMOTE HEBEL

THE HIGHLINE REMOTE FEATURES A UNIQUE SPHERICAL ADJUSTMENT, WITH NEAR-INFINITE ROTATION AND TILT CUSTOMIZATION OPTIONS, FOR PERFECT COCKPIT ERGONOMICS.

DANK DES EINMALIGEN KUGELKOPF DESIGNS BIETET DER HIGHLINE REMOTE HEBEL NAHEZU UNBEGRENZTE MÖGLICHKEITEN IN DER ANPASSUNG, UM SOMIT EINE PERFEKTE ERGONOMIE AM COCKPIT ZU ERHALTEN.



**HIGHLINE EVO**  
FLATBAR DROPPER POST REMOTE KIT  
MATCHMAKER



**HIGHLINE EVO**  
FLATBAR DROPPER POST REMOTE KIT  
22.2 CLAMP



**HIGHLINE EVO**  
FLATBAR DROPPER POST REMOTE KIT  
I-SPEC EV



**HIGHLINE**  
FLATBAR DROPPER POST REMOTE KIT  
22.2 CLAMP



**HIGHLINE**  
DROPBAR DROPPER POST REMOTE KIT V2

ARTICLE	UPC	MODEL	PRICE (€)
16754	641300167545	highline EVO - flatbar dropper post remote kit 22.2 clamp	70
16755	641300167552	highline EVO - flatbar dropper post remote kit matchmaker	70
16756	641300167569	highline EVO - flatbar dropper post remote kit I-Spec EV	70
16066	641300160669	highline remote kit 22.2 clamp	60
16824	641300168245	highline dropbar remote kit V2	50



# CIGAR TOOL

COMPACT TUBELESS TIRE REPAIR KIT INCLUDING CO2 ADAPTER  
KOMPAKTES REPARATURSET FÜR TUBELESS REIFEN INKLUSIVE CO2 ADAPTER

## PLUG KIT + CO2 HEAD

### MOUNTING BRACKET

Bottle cage bracket to mount the tool to bicycle frame

Flaschenhalter-Halterung zur Befestigung des Werkzeugs am Fahrradrahmen

### Co2 HEAD

klic Co2 cartridge adaptor (presta only) allows use of Co2 cartridge

klic Co2-Kartuschenadapter (nur Presta) ermöglicht die Verwendung von Co2-Kartuschen

Co2 cartridge sold separately  
Co2-Patrone separat erhältlich



### STORAGE CASE

Aluminum storage case with threaded top cap for Co2

Aluminium-Aufbewahrungsbehälter mit Gewindeaufsatz für Co2 Patrone

### TIRE PLUG TOOL

plunger tool screws into cap of the case, doubles as handle

Plunger-Werkzeug wird in die Kappe des Gehäuses geschraubt und dient gleichzeitig als Griff

### FEATURES

- tire plug tool
- tire plugs (5)
- Co2 head
- storage case
- mounting bracket
- 5 year warranty
- weight 55g

### EIGENSCHAFTEN

- Reifenstopfen-Werkzeug
- Reifenstopfen (5)
- Co2-Adapter
- Aufbewahrungsbehälter
- Halterung
- 5 Jahre Garantie
- Gewicht 55g

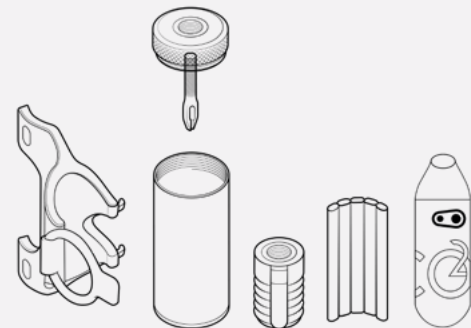

ARTICLE	UPC	MODEL	COLOR	WEIGHT	PRICE (€)
16570	641300165701	<b>tool cigar</b>	black/silver	55g	30
16637	641300166371	<b>tire plug refill kit (10 pieces)</b>	-	-	5

# TOOLS

NEW

## S.O.S TT17 TWIN TUBE KIT SOS TOOLS

- 2, 2.5, 3, 4, 5, 6, 8mm hex
- T25 torx tool
- Flat screwdriver
- Tire plug tool + 2x plugs
- Tire lever
- Chain tool
- Spoke wrenches 0, 1, 2
- Valve core tool
- CO2 head
- Storage tube
- 247g
- Fits a spare chain link + 16/20g CO2, sold separately

- 2, 2.5, 3, 4, 5, 6, 8 mm Sechskantschlüssel
- T25 Torx-Werkzeug
- Flacher Schraubendreher
- Reifenstopfwerkzeug + 2x Stopfen
- Reifenheber
- Kettenwerkzeug
- Speichenschlüssel 0, 1, 2
- Ventilkernwerkzeug
- CO2-Adapter
- Aufbewahrungsröhre
- 247g
- Passt für ein Ersatzkettenglied + 16/20 g CO2, separat erhältlich



## S.O.S BC18 BOTTLE CAGE KIT SOS TOOLS

- Reversible left / right entry bottle cage design
- 2, 2.5, 3, 4, 5, 6, 8mm hex
- T10, T25 torx tools
- Flat screwdriver
- Tire plug tool + 4x plugs
- Tire lever
- Chain tool
- Spoke wrenches 0, 1, 2
- Valve core tool
- CO2 head
- 247g
- Fits a spare chain link + 16/20/25g CO2 or Crankbrothers Klic HV pump, sold separately
- Optimized width for maximum pedaling clearance

- Umkehrbares Flaschenhalter-Design für links/rechts-Flaschen-Einschub
- 2, 2.5, 3, 4, 5, 6, 8 mm Sechskant
- Torx-Werkzeuge T10, T25
- Flacher Schraubendreher
- Reifenflickwerkzeug + 4x Flickstücke
- Reifenheber
- Kettenwerkzeug
- Speichenschlüssel 0, 1, 2
- Ventilkernwerkzeug
- CO2-Kopf
- 247g
- Passt zu einem Ersatzkettenschlussglied + 16/20/25g CO2 oder Crankbrothers Klic HV Pumpe, separat erhältlich
- Optimale Breite für maximale Pedalfreiheit



## S.O.S BC2 BOTTLE CAGE + SOS TOOLS

- Reversible left / right entry bottle cage design
- Tire plug tool + 2x plugs
- Tire lever
- 73g

- Umkehrbares Flaschenkäfigdesign für links/rechts-Einführung
- Reifen Plug Tool + 2x Plugs
- Reifenheber
- 73g





# TOOLS

**NEW**

## S.O.S TS2 TUBE STASH + SOS TOOLS

- Tube / gear storage with hook-and-loop strap
- Tire plug tool + 2x plugs
- Tire lever
- 53g

- Aufbewahrung für Schlauch/Ausrüstung mit Klettverschlussband
- Reifen Plug Tool + 2x Plugs
- Reifenheber
- 53g



## S.O.S TS18 TUBE STASH KIT SOS TOOLS

- Tube / gear storage with hook-and-loop strap
- 2, 2.5, 3, 4, 5, 6, 8mm hex
- T10, T25 torx tools
- Flat screwdriver
- Tire plug tool + 4x plugs
- Tire lever
- Chain tool
- Spoke wrenches 0, 1, 2
- Valve core tool
- CO2 head
- 229g
- Fits a spare chain link + 16/20/25g CO2 or Crankbrothers Klic HV pump, sold separately
- Optimized width for maximum pedaling clearance

- Aufbewahrung für Schlauch/Ausrüstung mit Klettverschlussband
- 2, 2.5, 3, 4, 5, 6, 8 mm Sechskantschlüssel
- T10, T25 Torx-Werkzeuge
- Flacher Schraubendreher
- Reifen Plug Tool + 4x Plugs
- Reifenheber
- Kettenwerkzeug
- Speichenschlüssel 0, 1, 2
- Ventilkernwerkzeug
- CO2-Adapter
- 229g
- Passt für ein Ersatzkettenglied + 16/20/25 g CO2 oder Crankbrothers Klic HV-Pumpe (separat erhältlich)
- Optimierte Breite für maximale Tretfreiheit



ARTICLE	UPC	NEW	MODEL	PRICE (€)
16774	641300167743	<b>NEW</b>	<b>tool S.O.S. TT17 twin tube tool kit</b>	120
16776	641300167767	<b>NEW</b>	<b>tool S.O.S. BC18 bottle cage kit</b>	100
16775	641300167750	<b>NEW</b>	<b>tool S.O.S. BC2 bottle cage +</b>	40
16777	641300167774	<b>NEW</b>	<b>tool S.O.S. TS2 tube stash +</b>	30
16778	641300167781	<b>NEW</b>	<b>tool S.O.S. TS18 tube stash tool kit</b>	90



# TOOLS

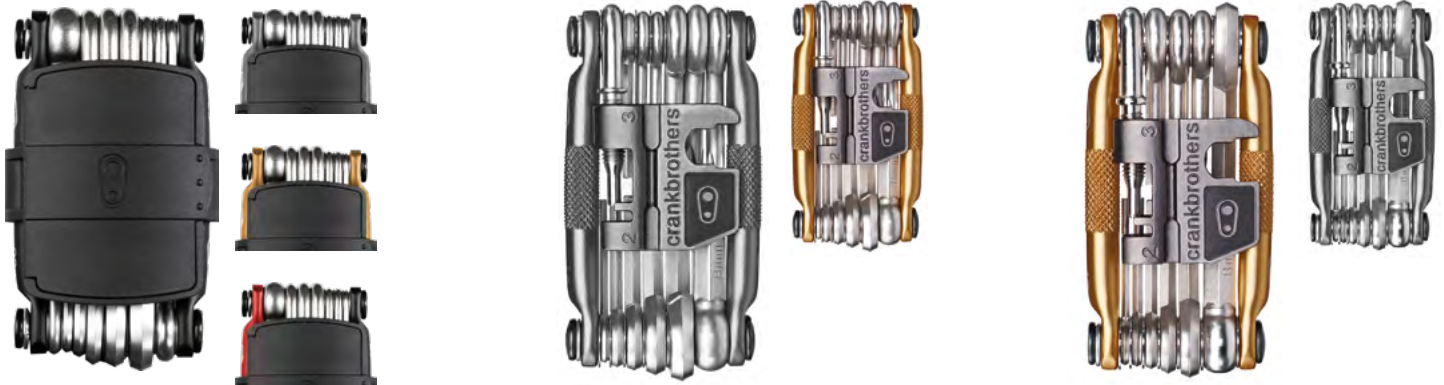

M20

M19

M17



M17 - SPLATTER EDITION

M13

M10

M5

ARTICLE	UPC	MODEL	COLOR	WEIGHT	PRICE (€)
16403	641300164032	<b>multi 20</b>	matte black	203g	40
16402	641300164025		nickel		40
16405	641300164056		gold		40
16404	641300164049		matte black/red		40
11465	641300352194	<b>multi 19</b>	nickel	175g	37
10758	641300351197		gold		37
10752	641300350176	<b>multi 17</b>	nickel	168g	30
10755	641300351173		gold		30
16679	641300166791		<b>multi 17 splatter edition</b>		red*
16681	641300166814		green*	168g	30
16682	641300166821		blue*	30	30
16399	641300163998	<b>multi 13</b>	matte black	164g	27
16398	641300163981		nickel		27
16401	641300164018		gold		27
16400	641300164001		matte black/red		27
10747	641300350107	<b>multi 10</b>	nickel	124g	20
10750	641300351104		gold		20
10743	641300350053	<b>multi 5</b>	nickel	85g	15
10745	641300351050		gold		15

(\*) Until sold out | Solange der Vorrat reicht



# TOOLS



F16

F11

F15

F10+

## TOOL BITS

	HEX 2	HEX 2.5	HEX 3	HEX 4	HEX 5	HEX 6	HEX 8	PHIL #1	PHIL #2	FLAT	TORX 10	TORX 25	OPEN WRENCH 8MM	OPEN WRENCH 10MM	ROTOR ALIGNMENT	CHAIN TOOL	SPOKE WRENCH	VALVE CORE TOOL	TIRE PLUG TECH	
M5 85g			●	●	●	●			●											
M10 150g	●	●	●	●	●	●	●		●	●		●								
M13 164g	●	●	●	●	●	●	●	●	●	●	●	●						●	●	
M17 168g	●	●	●	●	●	●	●		●	●		●	●	●			●	●		
M19 175g	●	●	●	●	●	●	●	●	●	●	●	●	●	●			●	●		
M20 203g	●	●	●	●	●	●	●	●	●	●	●	●	●		●	●	●	●	●	●
F10 116g	●	●	●	●	●	●	●		●	●		●								
F11 131g	●	●	●	●	●	●	●		●	●		●								●
F15 164g	●	●	●	●	●	●	●		●	●		●				●	●			
F16 179g	●	●	●	●	●	●	●		●	●		●				●	●			●

ARTICLE	UPC	MODEL	COLOR	WEIGHT	PRICE (€)
16753	641300167538	<b>f16</b>	black	179g	60
16092	641300160928	<b>f15</b>	black/silver	169g	50
16752	641300167521	<b>f11</b>	black	131g	50
16091	641300160911	<b>f10+</b>	black/silver	121g	40



PUMPS & CO<sub>2</sub>

## THE WORKSHOP ESSENTIAL



## FLOOR PUMPS

# KLIC FLOOR PUMPS

- Magnetic hose attachment
- Hidden hose in the body of the floor pump
- Quick connect for gauge to be mounted to pump
- Hose is magnetically held inside the pump
- Tripod base for added stability
- Burst tank can hold 160 psi / 11 bar
- Universal head for presta/schrader
- Large, accurate digital or analog gauge
- Burst tank can be charged to install and inflate tubeless tires with ease
- Tank is removable for easy transport

- Magnetischer Schlauch Anschluss
- Versteckter Schlauch im Pumpenkörper
- Schnellverschluss um Manometer anzubringen
- Schlauch wird magnetisch im Pumpenkörper aufbewahrt
- Dreibein Standfuß für verbesserte Stabilität
- Burst Tank hält bis zu 160 psi / 11 bar
- Universeller Pumpenkopf für Presta/Schrader
- Großes, genaues digital oder analog Manometer
- Burst Tank kann aufgeladen werden, für einfaches montieren und befüllen von Tubeless Reifen
- Der Tank ist abnehmbar für einen einfachen Transport



### REMOVABLE BURST TANK

Install and inflate tubeless tires with ease.

### ABNEHMBARER BURST TANK

Tubeless Reifen mit Leichtigkeit montieren und befüllen.



### HIDDEN HOSE

Stores neatly away in the pump body when not in use.

### VERSTECKTER SCHLAUCH

Lässt sich bei Nichtgebrauch platzsparend im Pumpenkörper verstauen.



### MAGNETIC QUICK-CONNECT

Easy interface for hose and burst tank.

### MAGNETISCHER SCHNELLVERSCHLUSS

Einfacher Verbindung von Schlauch und Burst Tank.

UNIVERSAL HEAD FOR PRESTA/SCHRADER  
(FULLY THREADED PRESTA VALVE BODIES ONLY)

UNIVERSALKOPF FÜR PRESTA/SCHRADER  
(NURPRESTA-VENTILKÖRPER MIT VOLLGEWINDE)



ARTICLE	UPC	MODEL	COLOR	PSI / BAR	PRICE (€)
16197	641300161970	<b>klic w/ digital gauge + canister</b>	silver	160 psi / 11 bar	250
16198	641300161987	<b>klic w/ analog gauge + canister</b>	silver	160 psi / 11 bar	220

FLOOR PUMPS

STERLING FLOOR PUMP

- Foot activated high pressure / high volume switch
  - Lightweight alloy base for stability
  - Corrosion resistant aluminum body and base
  - Smart head: presta & schrader ready
  - Bar / psi gauge
- 
- High Pressure / High Volume einstellbar über Fußschalter
  - Leichter, stabiler Aluminium Standfuß
  - Rostfreier Aluminiumkörper
  - Smart head: Presta & Schrader ready
  - Bar / psi Anzeige



SAPPHIRE FLOOR PUMP



GEM FLOOR PUMPS



ARTICLE	UPC	MODEL	COLOR	PSI / BAR	HEAD	BASE	PRICE (€)
16168	641300161680	<b>sterling</b>	silver	160 psi / 11 bar	universal presta / schrader	alloy	80
16303	641300163035	<b>sapphire</b>	black	160 psi / 11 bar	universal presta / schrader	steel	60
16218	641300162182		black				60
16205	641300162052	<b>gem</b>	red	160 psi / 11 bar	2 stage presta / schrader	steel	60
16206	641300162069		green				60



CO<sub>2</sub>

# CO<sub>2</sub> CARTRIDGE



ARTICLE	UPC	MODEL	WEIGHT	DESCRIPTION	PRICE (€)
16235	641300162359		co2 25g cartridge	20 units bulk pack	121
16232	641300162328	<b>co2 cartridge</b>	co2 25g cartridge	(2 units) w/ inflator	20
16230	64130016230		co2 16g cartridge	(2 units) w/ inflator	16

## HAND PUMPS

# KLIC HAND PUMPS

- Hidden flexible hose inside (all models)
- Magnetic head with twisting collar to keep out dirt and debris
- Magnetic hose end to attach hose to head quickly and easily
- Presta and schrader ready
- Folding and locking handle on all models
- Gauge incorporated on select models
- CO2 adaptor incorporated into handle on select models
- All pumps come with frame mounting bracket
- 5 Year warranty

- Versteckter, flexibler Schlauch (in allen Modellen enthalten)
- Magnetischer, abgewinkelter Pumpenkopf beugt Verschmutzung vor
- Magnetisches Ende für einfache und schnelle Montage
- Presta und Schrader ready
- falt- und arretierbarer Griff an allen Modellen
- Ausgewählte Modelle mit Manometer
- CO2 Adapter im Griff an ausgewählten Modellen
- Alle Pumpen werden mit einem Rahmenhalter ausgeliefert
- 5 Jahre Garantie



### PRESTA / SCHRADER READY

Unscrew and flip the head to switch between Presta and Schrader.

### PRESTA / SCHRADER READY

Durch einfaches umdrehen zwischen Presta & Schrader wechseln.



### TIRE PRESSURE GAUGE

Highly accurate and easy to read gauge on select models.

### REIFENDRUCK ANZEIGE

Sehr akkurate und gut ablesbare Anzeige.



### MAGNETIC HEAD WITH TWISTING COLLAR

Magnetic head with twisting collar to keep out dirt and debris. Magnetic hose end to attach hose to head quickly and easily.

### MAGNETISCHER, ABGEWINKELTER PUMPENKOPF

Der magnetische, abgewinkelte Pumpenkopf beugt Verschmutzung vor. Magnetische Anschlüsse für einfache und schnelle Montage.



### HIDDEN, FLEXIBLE HOSE & LOCKING HANDLE W/ CO2 ADAPTER

Folding handle unlocks to reveal hidden hose. Magnetic head with twisting collar to keep out dirt and debris. CO2 head integrated on select models.

### VERSTECKTER, FLEXIBLER SCHLAUCH

Verdeckter Schlauch unter dem Klappgriff. Magnetischer, abgewinkelter Pumpenkopf beugt Verschmutzung vor. Integrierter CO2 Anschluss an ausgewählten Modellen.



## HAND PUMPS

### KLIC HP

ROAD SPECIFIC HIGH PRESSURE: 120 PSI / 8.3 BAR



### KLIC HV

MTB SPECIFIC HIGH VOLUME: 110 PSI / 7.6 BAR



## GEM HAND PUMP

130+ PSI / 9+ BAR

Premium pumps featuring a patented high volume / high pressure switch for easy inflation, with a smart head that automatically adjusts to schrader or presta.  
Available in three colors, with or without a gauge.

Diese premium Pumpen verfügen über ein patentierten High Volume/High Pressure Wahlschalter, der ein einfaches Befüllen ermöglicht. Unser Smart Head Pumpenkopf wechselt automatisch zwischen Presta und Schrader Ventil.  
Verfügbar in drei Farben, mit oder ohne Manometer.



ARTICLE	UPC	MODEL	DESCRIPTION	COLOR	LENGTH	WEIGHT	PRICE (€)
16116	641300161161		klic hp gauge w/ co2		260mm	142g	60
16114	641300161147	<b>klic hp</b>	klic hp gauge	silver	260mm	132g	50
16112	641300161123		klic hp		260mm	102g	40
16117	641300161178		klic hv gauge w/ co2		260mm	145g	60
16115	641300161154	<b>klic hv</b>	klic hv gauge	silver	260mm	135g	50
16113	641300161130		klic hv		260mm	105g	40
14683	641300146830			red			25
14685	641300146854	<b>gem S</b>	-	green	176mm	131g	25
14681	641300146816			silver			25



**Continental**   
The Future in Motion



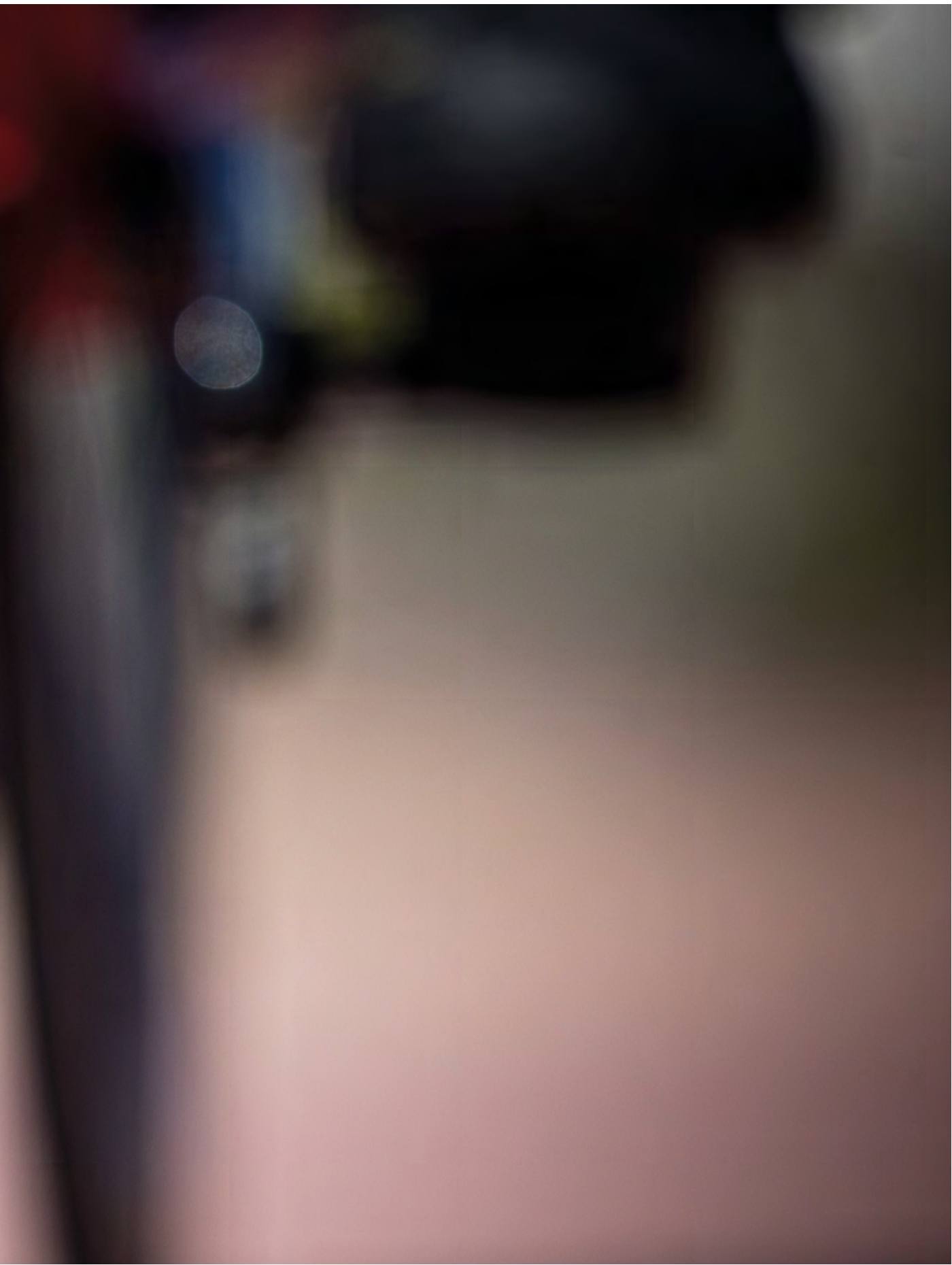

# MADE IN GERMANY



## **PASSION AND TECHNOLOGY**

**Producing the best tyres is only just good enough for us. That's why our designers and engineers are always working continuously to make our products even more efficient, developing new or improved formulations for our rubber compounds for example. These changes are not always visible at first glance, but they are definitely noticeable. Ride the difference, ride "handmade in Germany".**

Continental, the only German manufacturer of bicycle tyres in Germany. "Handmade in Germany" denotes that the tyres are produced in our Korbach plant, mostly by hand and with a high proportion of manual labour from tyre design to the final quality control. For you this means offering your customers tyres with German technology - a tradition since 1871.

## **LEIDENSCHAFT UND TECHNOLOGIE**

**Die bestmöglichen Reifen herzustellen, ist uns gerade gut genug. Deswegen arbeiten unsere Entwickler und Ingenieure auch kontinuierlich daran, unsere Produkte noch effizienter zu gestalten. Mit neuen oder verbesserten Rezepturen für unsere Gummimischungen beispielsweise. Nicht immer sind diese Änderungen auf den ersten Blick sichtbar. Spürbar sind sie auf jeden Fall. Fahren Sie den Unterschied - handmade in Germany.**

Continental, der einzige deutsche Fahrradreifenhersteller mit Produktion in Deutschland. "Handmade in Germany" – das heißt, dass die Reifen an unserem Standort Korbach maßgeblich in Handarbeit und mit einem hohen Anteil manueller Arbeitsschritte gefertigt werden. Vom Aufbau der Reifen bis zu ihrer abschließenden Qualitätskontrolle. Für Sie bedeutet das, Ihren Kunden Reifen mit deutscher Technik anbieten zu können - aus Tradition seit 1871.



### **PASSION AND ACCURACY**

**Only materials of the highest quality are used for making our tubular tyres. The individual elements are precisely combined and bonded. The most successful cyclists in the world put their faith in our work. Whether on the road or track, tubular tyres made by Continental have made their mark on competitions throughout the world.**

- Eleven out of twelve tyres produced in our Korbach plant are handmade
- The tube is sewn directly onto the carcass with about 400 stitches
- German technology from the tread compound mixture to completion
- 100 % quality audit

### **ADVANTAGES**

**Light:** lower weight than a clincher tyre  
**Fast:** high speeds due to reduced rolling resistance  
**Fit:** can be used with high tyre pressures  
**Safe:** in the event of a puncture, the tyre will not slide off the rim in action: perfect for competition.  
Ask the pros!

### **LEIDENSCHAFT UND PRÄZISION**

**Für unsere Schlauchreifen kommen ausschließlich die hochwertigsten Materialien zum Einsatz. Die einzelnen Komponenten werden in Maßarbeit zusammengesetzt und miteinander verbunden. Dieser Arbeit vertrauen auch die erfolgreichsten Athleten der Welt. Ob auf der Straße oder auf der Bahn – Schlauchreifen von Continental prägen die Wettkämpfe weltweit.**

- Elf von zwölf Reifen werden von Hand in unserem Werk in Korbach gefertigt
- Der Schlauch wird mit rund 400 Stichen direkt in die Karkasse eingenäht
- Deutsche Technik von der Mischung bis zur Fertigstellung
- 100 % Qualitätsprüfung

### **VORTEILE**

**Leicht:** geringeres Gewicht als Clincher  
**Schnell:** hohe Geschwindigkeiten durch reduzierten Rollwiderstand  
**Sitz:** auch hohe Reifendrucke fahrbar  
**Sicher:** im Fall einer Panne springt der Reifen nicht von der Felge im Einsatz: perfekt für den Wettkampf

# ROAD





## Grand Prix 5000 [Clincher]

### IT'S YOUR TIME!

The new era in cycling - the best allrounder in the field, brought to a whole new performance level!

Die neue Ära im Rennradsport - der beste Allrounder im Feld auf einem völlig neuen Performance-Level!



**Lazer Grip**, to make you one with the road. The lazed micro profile structure expands over the tire's shoulder and provides out-standing cornering.

**Lazer Grip**, Lässt dich eins werden mit der Straße. Die gelaserte Mikro-Profilstruktur konzentriert sich auf den Schulterbereich des Reifens und bietet dir so erhöhten Kurvengrip.



**Active Comfort Technology**, The revolutionary approach in cycling. Embedded in the tire construction the Active Comfort Technology absorbs vibrations and smoothens your ride.

**Der revolutionäre Ansatz im Rennradsport.** In die Reifenkonstruktion integriert, absorbiert die Active Comfort Technologie Erschütterungen und sorgt für ein überragendes Fahrgefühl.

ARTICLE	EAN	ETRTO	DIMENSION	COLOR/SIDEWALL	TECHNOLOGY	WEIGHT	BAR	MAX.BAR	PRICE (€)
<b>Grand Prix 5000</b>									
C0101624	4019238007824	25-622	28"1700x25 C	black/black skin foldable	Vectran B./LazerGrip/ACT	215g	6,50	8,50	74,99
C0101895	4019238056235	25-622	28"1700x25 C	black/transparent fold.	Vectran B./LazerGrip/ACT	225g	6,50	8,50	74,99
C0101947	4019238 064711	25-622	28"1700x25C	black/cream foldable	Vectran B./LazerGrip/ACT	260g	6,50	8,50	74,99
C0101625	4019238007848	28-622	28"1700x28 C	black/black skin foldable	Vectran B./LazerGrip/ACT	235g	6,50	8,00	74,99
C0101896	4019238056242	28-622	28"1700x28 C	black/transparent fold.	Vectran B./LazerGrip/ACT	235g	6,50	8,50	74,99
C0101948	4019238 064728	28-622	28"1700x28C	black/cream foldable	Vectran B./LazerGrip/ACT	290g	6,50	8,00	74,99
C0101813	4019238041972	30-622	28"1700x30 C	black/black skin foldable	Vectran B./LazerGrip/ACT	260g	6,00	7,00	74,99
C0101626	4019238007855	32-622	28"1700x32 C	black/black skin foldable	Vectran B./LazerGrip/ACT	290g	6,00	7,00	74,99



### Grand Prix 5000 TL [Tubeless]

**TUBELESS-VERSION.** The new Grand Prix 5000 S Tubeless Ready: Lighter, faster and with stronger sidewalls. The new standard in road tubeless ready technology. Ride faster, more comfortable and with increased puncture protection. Made to make you better.

**TUBELESS-VERSION.** Der neue Grand Prix 5000 S Tubeless Ready: leichter, schneller und mit stabileren Seitenwänden. Der neue Standard in Sachen Tubeless Ready-Technologie fürs Rennrad. Fahren Sie schneller, komfortabler und mit einem optimierten Pannenschutz. Hergestellt, damit Sie Ihre Leistungsfähigkeit entfalten können.



**Lazer Grip**, to make you one with the road. The lazered micro profile structure expands over the tire's shoulder and provides out-standing cornering.

**Lazer Grip**, Lässt dich eins werden mit der Straße. Die gelaserte Mikro-Profilstruktur konzentriert sich auf den Schulterbereich des Reifens und bietet dir so erhöhten Kurvengrip.



**Active Comfort Technology**, The revolutionary approach in cycling. Embedded in the tire construction the Active Comfort Technology absorbs vibrations and smoothens your ride.

**Der revolutionäre Ansatz im Rennradsport.** In die Reifenkonstruktion integriert, absorbiert die Active Comfort Technologie Erschütterungen und sorgt für ein überragendes Fahrgefühl.



**Tubeless Ready Bead**, Specifically developed the Tubeless bead seals through its unique shape and provides stable fitting on the rim.

**Tubeless Ready Bead**, Speziell entwickelt, dichtet der Tubeless-Fuß durch seine Form besonders ab und sorgt für stabilen Halt auf der Felge.

ARTICLE	EAN	ETRTO	DIMENSION	COLOR/SIDEWALL	TECHNOLOGY	WEIGHT	BAR	MAX.BAR	PRICE (€)
<b>Grand Prix 5000 S Tubeless</b>									
C0101866	4019238054439	25-622	28"   700x25C	black/black skin fold.	Vectran B./LazerGrip/ACT	245g	5,0	7,5	87,99
C0101873	4019238055559	25-622	28"   700x25C	black/transparent fold.	Vectran B./LazerGrip/ACT	295g	5,0	7,5	87,99
C0101867	4019238054422	28-622	28"   700x28C	black/black skin fold.	Vectran B./LazerGrip/ACT	270g	5,0	6,5	87,99
C0101874	4019238055580	28-622	28"   700x28C	black/transparent fold.	Vectran B./LazerGrip/ACT	315g	5,0	6,5	87,99
C0101869	4019238054408	32-622	28"   700x32C	black/black skin fold.	Vectran B./LazerGrip/ACT	320g	3,5	5,0	87,99
C0101876	4019238055641	32-622	28"   700x32C	black/transparent fold.	Vectran B./LazerGrip/ACT	375g	3,5	5,0	87,99



### Grand Prix 5000 AllSeason TR

**FOR THE EXTRA MILE.** The strongest Grand Prix 5000: creates trust in all weather conditions and boosts your protection.

**FÜR DIE EXTRA MEILE.** Der stärkste Grand Prix 5000: schafft Vertrauen in allen Wetterbedingungen und erhöht deinen Schutz.



**Lazer Grip.** to make you one with the road. The lazed micro profile structure expands over the tire's shoulder and provides out-standing cornering.

**Lazer Grip.** Lässt dich eins werden mit der Straße. Die gelaserte Mikro-Profilstruktur konzentriert sich auf den Schulterbereich des Reifens und bietet dir so erhöhten Kurvengrip.



**Active Comfort Technology.** The revolutionary approach in cycling. Embedded in the tire construction the Active Comfort Technology absorbs vibrations and smoothens your ride.

**Der revolutionäre Ansatz im Rennradsport.** In die Reifenkonstruktion integriert, absorbiert die Active Comfort Technologie Erschütterungen und sorgt für ein überragendes Fahrgefühl.



**Tubeless Ready Bead.** Specifically developed the Tubeless bead seals through its unique shape and provides stable fitting on the rim.

**Tubeless Ready Bead.** Speziell entwickelt, dichtet der Tubeless-Fuß durch seine Form besonders ab und sorgt für stabilen Halt auf der Felge.

ARTICLE	EAN	ETRTO	DIMENSION	COLOR/SIDEWALL	TECHNOLOGY	WEIGHT	BAR	MAX.BAR	PRICE (€)
<b>Grand Prix 5000 AllSeason TR</b>									
C0101910	4019238056754	25-622	28" 700x25 C	black/black reflex skin fold.	Vectran B./LazerGrip	250g	5,0	7,5	104,99
C0101911	4019238056815	28-622	28" 700x28 C	black/black reflex skin fold.	Vectran B./LazerGrip	280g	5,2	6,5	104,99
C0101912	4019238056914	32-622	28" 700x32 C	black/black reflex skin fold.	Vectran B./LazerGrip	325g	3,5	5,0	104,99
C0101913	4019238056990	35-622	28" 700x35 C	black/black reflex skin fold.	Vectran B./LazerGrip	325g	2,5	4,5	104,99
C0101901	4019238056716	25-622	28" 700x25 C	black/cream reflex skin fold.	Vectran B./LazerGrip	250g	5,1	7,5	99,99
C0101902	4019238056792	28-622	28" 700x28 C	black/cream reflex skin fold.	Vectran B./LazerGrip	280g	5,3	6,5	99,99
C0101903	4019238056884	32-622	28" 700x32 C	black/cream reflex skin fold.	Vectran B./LazerGrip	315g	3,5	5,1	99,99
C0101904	4019238056952	35-622	28" 700x35 C	black/cream reflex skin fold.	Vectran B./LazerGrip	315g	2,5	4,5	99,99





**Grand Prix 4-Season**

**OUR ALL-YEAR-ROUND TYRE AND A RELIABLE COMPANION FOR THOSE HIGH MILEAGE ROAD CYCLISTS.**

- solid partner for training rides and in competition, come rain or shine
- outstanding puncture protection, reliable tread with good grip and the highest mileage
- a tyre with a superior durability ready for any season

**UNSER GANZJAHRESREIFEN UND EIN VERLÄSSLICHER BEGLEITER FÜR VIELFAHRER - IN JEDER SEASON.**

- solider Touren und Trainingsbegleiter der weder Sonne noch Regen • widerstandsfähiger Partner für Touren, Training und Wettkampf, der weder Sonne noch Regen scheut
- hervorragender Pannenschutz, griffiges, bewährtes Profil und höchste Laufleistung
- ein Reifen mit souveräner Haltbarkeit, mit dem Sie für jede Saison gerüstet sind



**Grand Prix**

**MOUNTAIN TOP FINISH: A COMFORTABLE ALL-ROUNDER THAT HAS BEEN WRITTEN INTO CYCLING HISTORY.**

- an all-rounder designed to be tough, made for sporty trips across demanding terrain
- offers high puncture protection, comfort and good grip
- with high mileage, available in many sizes

**BERGANKUNFT: EIN KOMFORTABLER ALLESKÖNNER, DER RADSPORTGESCHICHTE GESCHRIEBEN HAT.**

- ein Allrounder mit solidem Aufbau, gemacht für sportliche Ausfahrten in anspruchsvollem Terrain
- bietet hohen Pannenschutz, Komfort und ordentlich Grip
- mit besonders hoher Laufleistung und in vielen Größen verfügbar



ARTICLE	EAN	ETRTO	DIMENSION	COLOR/SIDEWALL	TECHNOLOGY	WEIGHT	BAR	MAX.BAR	PRICE (€)
<b>Grand Prix 4-Season</b>									
C0100175	4019238409116	25-622	700x25 C	black DuraSkin fold.	Double Vectran Breaker	230g	6,5	8,5	74,99
C0101105	4019238674620	28-622	700x28 C	black DuraSkin fold.	Double Vectran Breaker	295g	6,5	8,0	74,99
C0101095	4019238668131	32-622	700x32 C	black DuraSkin fold.	Double Vectran Breaker	340g	6,0	7,0	74,99
<b>Grand Prix</b>									
C0100506	4019238564617	23-622	700x23 C	black foldable	PolyX Breaker	225g	7,5	8,5	49,99
C0100637	4019238581409	25-622	700x25 C	black foldable	PolyX Breaker	230g	7,5	8,5	49,99
C0101109	4019238674590	28-622	700x28 C	black foldable	PolyX Breaker	275g	6,5	8,0	49,99



### Grand Sport Race

#### A PURE RACER AND THE IDEAL TYRE FOR COMPETITIONS AND TOURS.

- this all-rounder is ready for every challenge, even the biggest ones
- reliable level of puncture protection thanks to NyTech Breaker insert, high mileage with PureGrip Compound
- proven Continental racing tyre contour for responsive handling and secure grip

#### EIN REINER RENNFÄHRER UND DER IDEALE REIFEN FÜR WETTKÄMPFE UND TOUREN.

- dieser Allrounder ist bereit für jede noch so große Herausforderung
- zuverlässiger Pannenschutz durch NyTech Breaker-Einlage, hohe Laufleistung durch PureGrip Mischung
- bewährte Continental-Rennreifenkontur für reaktionsschnelles Handling und sicheren Grip



### Ultra Sport III

**MODERN TIRE FOR THOSE NEW TO BICYCLE RACING.** Tires for general road bike riding and competitions. Comprehensive assortment for fine tuning your bike with outstanding value for money. Available in many sizes and colors.

**MODERNER EINSTIEGSREIFEN FÜR DEN RENNRADESPORT.** Reifen für Touren und Wettkampf, mit einem hervorragenden Preis-Leistungs-Verhältnis. Umfassende Auswahl für die Feinabstimmung auf den jeweiligen Einsatzzweck. Erhältlich in vielen Dimensionen und Farben.



ARTICLE	EAN	ETRTO	DIMENSION	COLOR/SIDEWALL	TECHNOLOGY	WEIGHT	BAR	MAX.BAR	PRICE (€)
<b>Grand Sport Race</b>									
C0150001	4019238586565	23-622	700x23 C	black foldable	NyTech Breaker	230g	7,5	8,5	39,99
C0150027	4019238587319	25-622	700x25 C	black foldable	NyTech Breaker	270g	6,5	8,5	39,99
C0150118	4019238621105	28-622	700x28 C	black foldable	NyTech Breaker	330g	5,5	8,0	39,99
<b>Ultra Sport III</b>									
C0150449	4019238026641	23-622	700x23 C	black skin foldable	Performance	320g	7,5	8,5	29,99
C0150457	4019238026849	25-622	700x25 C	black skin foldable	Performance	270g	6,5	8,5	29,99
C0150466	4019238026917	28-622	700x28 C	black skin foldable	Performance	420g	5,5	8,0	29,99

# TUBULAR





### Competition

#### A PURE RACER AND THE IDEAL TYRE FOR COMPETITIONS AND TOURS.

- robust all-rounder appearing at the sharp end in all the major cycle races around the world
- a high-performance tread compound coupled with reliable puncture protection
- agile and fast, adapts to the competition in all road conditions

#### ES IST WETTKAMPFZEIT: DER KLASSIKER FÜR DEN ANTRITT BEI RENNEN – NICHT NUR AUF DER PRO TOUR.

- robuster Allrounder, der bei allen großen Radrennen weltweit vorne mitfährt
- eine leistungsfähige Laufstreifenmischung trifft auf eine verlässliche Pannenschutzeinlage der Extraklasse
- wendig und schnell, passt sich der Competition allen auftretenden Straßengegebenheiten an

### Giro

#### FOR NEWCOMERS: THE PERFECT COMPANION FOR TRAINING AND LEISURE RIDES.

- a reliable all-round tyre, high quality for newcomers with high aspirations
- outstanding rolling characteristics and robust qualities that will make them last for many miles
- high mileage and excellent value for money

#### FÜR EINSTEIGER DER PERFEKTE BEGLEITER IM TRAINING UND AUF TOUR.

- ein verlässlicher Allroundreifen in bewährter Qualität für Einsteiger, die noch hoch hinaus wollen
- mit hervorragenden Abrolleigenschaften und Robustheit auch nach vielen Kilometern noch bereit für den Einsatz
- zeigt sich mit hoher Laufleistung und einem ausgezeichneten Preis-Leistungs-Verhältnis



ARTICLE	EAN	ETRTO	DIMENSION	COLOR/SIDEWALL	TECHNOLOGY	WEIGHT	BAR	MAX.BAR	PRICE (€)
<b>Competition</b>									
C0196189	4019238549126	-	28"x25 mm	black	Vectran Breaker	280g	8,0	12,0	130,99
<b>Giro</b>									
C0196017	4019238107715	-	28"x22 mm	black/transparent	Performance	390g	8,0	10,0	39,99



### Sprinter

**IF THE AIM IS WINNING POINTS THEN THIS NIMBLE SPURTER IS THE RIGHT TYRE FOR YOU.**

- efficient tyres for criteriums or triathlon where the tyres' characteristics will shine through
- proven puncture protection through the SafetySystem Breaker
- neutral slick profile for a direct feel with the road. Full speed ahead!

**WENN SIE HEIß AUF PUNKTE SIND, IST DIESER LEICHTE SPURTER DER RICHTIGE REIFEN.**

- effizienter Wettkampfreifen, der bei Kriterien und im Triathlon seine Stärken voll ausspielt
- bewährter Pannenschutz durch den SafetySystem Breaker
- das neutrale Slick-Profil sorgt für ein direktes Gefühl für die Straße. Volle Fahrt voraus!



### Sprinter Gatorskin

**THE SPURTER IN THE GROUP, DESIGNED FOR EXTENDED RIDES AND TRAINING.**

- the roads of Flanders, Roubaix and Sanremo are home to this tough tubular
- durable and puncture protected carcass, ready for hundreds of kilometres even on bad roads
- big volume ensures additional grip and improved rolling characteristics

**DER SPURTER IM PELOTON: ÜBERZEUGT AUF TOUREN UND IM TRAINING.**

- die Straßen von Flandern, Roubaix und San Remo sind das Zuhause dieses Marathonreifens
- langlebige und pannensichere Karkasse, gewappnet für hunderte Kilometer - gerade auf schlechten Straßen
- großes Volumen sorgt für zusätzliche Sicherheit und verbessertes Abrollen



ARTICLE	EAN	ETRTO	DIMENSION	COLOR/SIDEWALL	TECHNOLOGY	WEIGHT	BAR	MAX.BAR	PRICE (€)
<b>Sprinter</b>									
C0196244	4019238674576	-	28"x25 mm	black	SafetySystem Breaker	295g	8,0	12,0	66,99
<b>Sprinter Gatorskin</b>									
C0196187	4019238549089	-	28"x25 mm	black	SafetySystem Breaker	300g	8,0	12,0	84,99



### Vectran™ Breaker

The reference for puncture protection: Vectran™ is spun from liquid crystal-polymer. This way a thermoplastic, multiple-thread yarn is created. As a comparison: this partially crystalline fabric is more cut-resistant than aramide and its tensile strength is five times higher than that of steel. A Vectran™ Breaker is lighter, more flexible and effective against cuts than a comparable nylon breaker. There is no detrimental effect on rolling resistance.

Die Referenz im Pannenschutz - Vectran™ wird aus dem Flüssigkristallpolymer Vectra gesponnen. Dadurch entsteht ein thermoplastisches, mehrfaseriges Garn. Zum Vergleich: Dieses teilkristalline Gewebe ist schnittfester als Aramid und besitzt eine fünfmal höhere Zugfestigkeit als Stahl. Ein Vectran™ Breaker ist leichter, flexibler und schützt effektiver vor Schnitten als vergleichbare Nylon-Breaker. Der Rollwiderstand wird dabei nicht negativ beeinflusst.

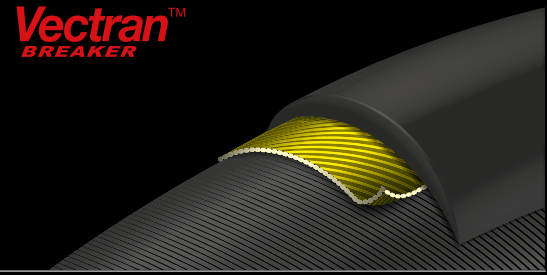

### PolyX Breaker™

With the PolyX Breaker™ we introduce technological know-how from automotive manufacturing to the bicycle tyre sector. Polyester has been used successfully in car tyres for years and has proven its worth. The extremely resilient polyester fibre is woven finely as a cross mesh. This way a high density of fabric is achieved which not only makes our breaker more robust against foreign objects, but also makes it particularly puncture resistant.

Mit dem PolyX Breaker™ bringen wir PKW-Know-How ins Fahrradreifensegment: Polyester wird seit Jahren erfolgreich in Autoreifen eingesetzt und hat sich vielfach bewährt. Die extrem widerstandsfähige Polyesterfaser wird engmaschig über Kreuz gewebt. Dadurch wird eine sehr hohe Gewebedichte erreicht, die den Breaker nicht nur widerstandsfähig gegenüber Fremdkörpern, sondern besonders resistent gegen Durchstiche macht. Der Rollwiderstand wird auch durch den PolyX Breaker™ nicht negativ beeinflusst.

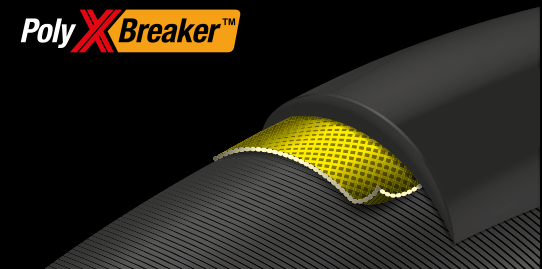

### DuraSkin®

Tyres with DuraSkin® sidewall protection can take a beating as they are designed for the most adverse conditions. In rough terrain on a cyclocross or a gravel bike, on commuter bikes where tyres scrape along curbs, on touring bikes as they cross continents encountering many different road qualities and on the race circuit where they prove themselves in endurance events such as the Paris-Roubaix. The high-quality polyamide fabric reliably protects the wall of the tyre. Tyres with DuraSkin® can be identified by the characteristic brown mesh sidewall.

Reifen mit DuraSkin®-Seitenwandschutz müssen ordentlich einstecken können. Sie kommen unter den widrigsten Bedingungen zum Einsatz. Auf Messenger-Bikes rutschen die Reifen an Bordsteinen entlang, auf Reiserädern durchqueren sie Kontinente ohne durchzuschuern, im Rennsport müssen sie Härteprüfungen wie Paris-Roubaix bestehen. Das hochwertige Polyamid-Gewebe schützt zuverlässig die Flanke des Reifens und wappnet den Reifen für das Äußerste. Aus der breiten Masse heben sich diese Reifen dank ihrer braunen Seitenwand hervor.



### NyTech Breaker

A puncture protection technology made of nylon fibres - protects similar to Kevlar but with low rolling resistance and reduced weight.

Eine Pannenschutztechnologie aus Nylonfaser - schützt ähnlich wie Kevlar und dabei mit geringerem Rollwiderstand und wenig Gewicht.

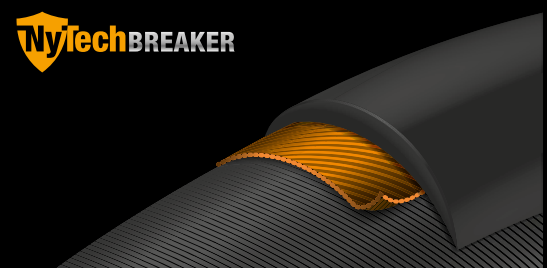

**Safety System**

Puncture and cut-proof, but still light and flexible, the tyre adapts better to the terrain. Provides particularly comfortable handling characteristics.

Stich- und schnittfest, dabei besonders leicht und flexibel passt sich der Reifen dem Untergrund besser an. Bietet besonders komfortable Fahreigenschaften.

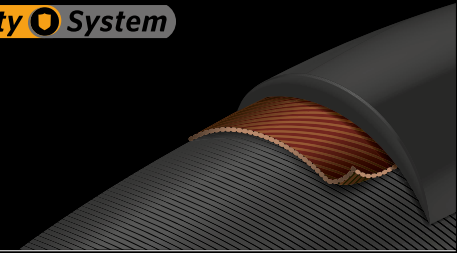
**Safety O System****BlackChili Compound**

With our unique tread compound, which is produced only in Germany, we have revolutionised the sport of cycling. With the legendary BlackChili Compound we have answered the eternal question of the best balance of grip and rolling resistance for cycling. Regular test wins confirm the measurable and noticeable advantages for the cyclist, established in the laboratory and on the road. The latest polymers as well as specially developed carbon black particles and filler materials guarantee unique performance, be it on a road or a mountain bike, for time trialling or downhill. In contrast to conventional silica compounds: more mileage [+5 %]; improved rolling resistance by 26 % while grip is enhanced by 30 % at the same time; consistent handling characteristics from the first to the last kilometre.

Mit unserer einzigartigen, nur in Deutschland hergestellten Laufstreifenmischung haben wir die Radsportszene revolutioniert. Durch das legendäre BlackChili Compound konnten wir die ewige Frage, ob Grip oder Rollwiderstand nachhaltig beantworten. Regelmäßige Testsiege belegen die im Labor und auf der Straße mess- und spürbaren Vorteile für die Fahrer. Neueste Polymere sowie speziell entwickelte Rußpartikel und Füllstoffe garantieren eine einzigartige Performance – ob auf dem Rennrad oder Mountainbike, zum Zeitfahren oder Downhill.

**PureGrip Compound**

PureGrip Compound is derived from an activated Silica compound and is a good example of how we integrate customer feedback continuously into our research and development. This mixture technology compliments the BlackChili Compound. The name PureGrip does exactly what it says; exceptionally good grip and durability are the distinguishing features of this compound. Tyres engineered with PureGrip can be found in our Performance products in our road and mountain bike ranges.

Auf Basis des aktivierten Silika Compounds wurde zielstrebig auf eine Mischungstechnologie im Performance-Segment hingearbeitet. Das Ergebnis unserer Korbacher Forschungs- und Entwicklungsabteilung brachte nach intensivem Entwicklungsaufwand eine neue Mischungstechnologie mit hervorragenden Grip- und Langlaufeigenschaften hervor. Die neue Gummimischung mit dem selbsterklärenden Namen „PureGrip“ reiht sich hinter unserem BlackChili Compound ein und wird in Performance-Produkten der Segmente Race und Mountainbike eingesetzt. Hier sorgt es für langanhaltende Traktion und hohe Laufleistung von Continental-Reifen, die exklusiv in der Produktionsstätte in Hefei (Asien) gefertigt werden.

**Tire Positioning System**

Know-how from motorcycle sport, specially adapted for bicycle racing to address the specific demands of front and rear wheels. Front: agile and direct. The narrower tyre provides reduced air resistance and improved steering characteristics. Rear: comfortable and dampening. With its slightly broader contact surface the tyre provides better traction. Thanks to the compound mix being optimised for rolling resistance, stiction is reduced. The result: a pioneering front and rear wheel tyre system in which the tyres have been painstakingly matched with one another.

Know-how aus dem Motorradsport, eigens übertragen auf den Rennradsport, um hier den speziellen Anforderungen für Vorder- und Hinterrad gerecht zu werden. Vorn: agil und direkt. Der schmalere Reifen sorgt für einen verringerten Luftwiderstand und ein verbessertes Lenkverhalten. Hinten: komfortabel und dämpfend. Hier mit einer etwas breiteren Aufstandsfläche sorgt der Reifen für verbesserte Traktion. Dank





**GRAVEL**





### Terra Speed

**CHOOSE ALTER ROAD, CHOOSE TERRA.** For your way off-road. For more comfort. For the adventure. Be it the long tour, or the shortcut on your way home. The new gravel Terra series by Continental gets you there. The Terra Speed is the fast model in our series. Made to get you over tarmac and sand.

**WÄHLEN SIE EINEN ALTERNATIVEN WEG, WÄHLEN SIE TERRA.** Für den Weg abseits der Straße. Für mehr Komfort. Für das Abenteuer. Ob ausgedehnte Tour oder die schnelle Abkürzung auf dem Weg nach Hause. Die neue Gravel Terra-Reihe von Continental bringt dich ans Ziel. Der Terra Speed ist dabei das schnelle Modell in unserer Serie. Gemacht, um dich über Asphalt und Sand zu bringen.

### Terra Trail

**CHOOSE ALTER ROAD, CHOOSE TERRA.** For your way off-road. For more comfort. For the adventure. Be it the long tour, or the shortcut on your way home. The new gravel Terra series by Continental gets you there. The Terra Trail is the nobbiest model in our series. Made to get you over rough and smooth.

**WÄHLEN SIE EINEN ALTERNATIVEN WEG, WÄHLEN SIE TERRA.** Für den Weg abseits der Straße. Für mehr Komfort. Für das Abenteuer. Ob ausgedehnte Tour oder die schnelle Abkürzung auf dem Weg nach Hause. Die neue Gravel Terra-Reihe von Continental bringt dich ans Ziel. Der Terra Trail ist dabei das stollenstärkste Modell in unserer Serie. Gemacht, um dich über Stock und Stein zu bringen.



ARTICLE	EAN	ETRTO	DIMENSION	COLOR/SIDEWALL	TECHNOLOGY	WEIGHT	BAR	MAX.BAR	PRICE (€)
<b>Terra Speed</b>									
C0101720	4019238029772	35-584	650x35 B   27.5x1.35	black/cream skin fold.	ProTectiOn	350g	3,0	5,0	69,99
C0101718	4019238029611	40-584	650x40 B   27.5x1.50	black/cream skin fold.	ProTectiOn	420g	3,0	5,0	69,99
C0101700	4019238026955	35-622	700x35 C   28x1.35	black/cream skin fold.	ProTectiOn	360g	3,0	5,0	69,99
C0101702	4019238027020	40-622	700x40 C   28x1.50	black/cream skin fold.	ProTectiOn	440g	3,0	5,0	69,99
C0101837	4019238052053	40-622	700x40 C   28x1.50	black/transp. skin fold.	ProTectiOn	440g	3,0	5,0	69,99
C0102007	4019238083439	45-622	700x45 C   28x1.70	black/transp. skin fold.	ProTectiOn	490g	3,0	5,0	69,99
C0101719	4019238029796	35-584	650x35 B   27.5x1.35	black/black foldable	ProTectiOn	390g	3,0	5,0	69,99
C0101693	4019238027013	35-622	700x35 C   28x1.35	black/black foldable	ProTectiOn	410g	3,0	5,0	69,99
C0101717	4019238029635	40-584	650x40 B   27.5x1.50	black/black foldable	ProTectiOn	420g	3,0	5,0	69,99
C0101694	4019238027099	40-622	700x40 C   28x1.50	black/black foldable	ProTectiOn	440g	3,0	5,0	69,99
<b>Terra Trail</b>									
C0101716	4019238029659	40-584	650x40 B   27.5x1.50	black/cream skin fold.	ProTectiOn	440g	3,0	5,0	69,99
C0101701	4019238027044	40-622	700x40 C   28x1.50	black/cream skin fold.	ProTectiOn	440g	3,0	5,0	69,99
C0101836	4019238052060	40-622	700x40 C   28x1.50	black/transp. skin fold.	ProTectiOn	440g	3,0	5,0	69,99
C0101715	4019238029673	40-584	650x40 B   27.5x1.50	black/black skin fold.	ProTectiOn	440g	3,0	5,0	69,99
C0101697	4019238027075	40-622	700x40 C   28x1.50	black/black skin fold.	ProTectiOn	460g	3,0	5,0	69,99
C0150509	4019238038507	47-584	650x47 B   27.5x1.75	black/black skin fold.	ShieldWall Syst.	520g	2,5	4,5	39,99
C0150508	4019238038538	47-584	650x47 B   27.5x1.75	black/cream skin fold.	ShieldWall Syst.	510g	2,5	4,5	39,99
C0150503	4019238038460	35-622	700x35 C   28x1.35	black/black skin fold.	ShieldWall Syst.	425g	3,0	5,0	39,99
C0150505	4019238038491	35-622	700x35 C   28x1.35	black/cream skin fold.	ShieldWall Syst.	445g	3,0	5,0	39,99
C0150507	4019238038545	40-622	700x40 C   28x1.50	black/black skin fold.	ShieldWall Syst.	495g	3,0	5,0	39,99
C0150673	4019238064506	40-622	700x40 C   28x1.50	black/brown skin fold.	ShieldWall Syst.	440g	3,0	5,0	39,99
C0150675	4019238064476	45-622	700x45 C   28x1.70	black/black skin fold.	ShieldWall Syst.	500g	2,5	4,5	39,99

# MOUNTAIN BIKE





Umido  
Terrain Mixte



KRYPTOTAL Fr

KRYPTOTAL Re



**Kryptotal <sup>Fr</sup>**

**SPECIALIST FOR MIXED TERRAIN AND CONDITIONS.** Designed to work with Kryptotal Re and optimised for front wheel maneuverability and agility. Ideal for mixed terrain conditions across trail, enduro and downhill gravity riding.

**DER SPEZIALIST FÜR UNTERSCHIEDLICHE UNTERGRÜNDE UND BEDINGUNGEN.** Konzipiert für die Kombination mit dem Kryptotal Re und optimiert für Manövrierbarkeit und Agilität am Vorderrad. Ideal für gemischte Bodenverhältnisse in den Segmenten Trail, Enduro und Downhill.

**Kryptotal <sup>Re</sup>**

**SPECIALIST FOR MIXED TERRAIN AND CONDITIONS.** Optimised for rear wheel, this all round tire balances stability of grip, traction for braking and rolling resistance. Ideal for mixed terrain conditions for you to push your limits in trail, enduro or downhill gravity riding.

**DER SPEZIALIST FÜR UNTERSCHIEDLICHE UNTERGRÜNDE UND BEDINGUNGEN.** Optimiert für den Einsatz am Hinterrad, bietet dieser Allround-Reifen ein ausgewogenes Verhältnis zwischen Grip, Traktion beim Bremsen und in Sachen Rollwiderstand. Ideal für gemischte Bodenverhältnisse, damit Sie beim Trail-, Enduro- oder Downhill-Riding an Ihre Grenzen gehen können.



ARTICLE	EAN	ETRTO	DIMENSION	COLOR/SIDEWALL	TECHNOLOGY	WEIGHT	BAR	MAX.BARPRICE (€)
<b>Kryptotal-F 2.4</b>								
C0101957	4019238070491	60-622	29"   29x2.40	black/black fold. skin	Downhill/Super Soft Comp.	1290g	2,5 3,5	99,00
C0150694	4019238074116	60-584	27.5"   27.5x2.40	black/black fold. skin	Enduro/Soft Comp.	1080g	2,5 3,5	85,00
C0150696	4019238074079	60-622	29"   29x2.40	black/black fold. skin	Enduro/Soft Comp.	1125g	2,5 3,5	85,00
C0150695	4019238074093	60-584	27.5"   27.5x2.40	black/black fold. skin	Trail/Endurance Comp.	1000g	2,5 3,5	73,00
C0150697	4019238074055	60-622	29"   29x2.40	black/black fold. skin	Trail/Endurance Comp.	1040g	2,5 3,5	73,00
<b>Kryptotal-R 2.4</b>								
C0101991	4019238080780	60-584	27.5"   27.5x2.40	black/black fold. skin	Downhill/Soft Comp.	1220g	2,5 3,5	95,00
C0101992	4019238080773	60-622	29"   29x2.40	black/black fold. skin	Downhill/Soft Comp.	1290g	2,5 3,5	95,00
C0101993	4019238080766	60-584	27.5"   27.5x2.40	black/black fold. skin	Enduro/Soft Comp.	1080g	2,5 3,5	85,00
C0150634	4019238063127	60-622	29"   29x2.40	black/black fold. skin	Enduro/Soft Comp.	1125g	2,5 3,5	85,00
C0150637	4019238063059	60-584	27.5"   27.5x2.40	black/black fold. skin	Trail/Endurance Comp.	1000g	2,5 3,5	73,00
C0150638	4019238063042	60-622	29"   29x2.40	black/black fold. skin	Trail/Endurance Comp.	1040g	2,5 3,5	73,00
<b>Kryptotal-R 2.6</b>								
C0150635	4019238063097	65-584	27.5"   27.5x2.60	black/black fold. skin	Enduro/Soft Comp.	1220g	2,0 3,0	89,00
C0150636	4019238063080	65-622	29"   29x2.60	black/black fold. skin	Enduro/Soft Comp.	1275g	2,0 3,0	89,00
C0150639	4019238063011	65-584	27.5"   27.5x2.60	black/black fold. skin	Trail/Endurance Comp.	1100g	2,0 3,0	81,00
C0150640	4019238063004	65-622	29"   29x2.60	black/black fold. skin	Trail/Endurance Comp.	1200g	2,0 3,0	81,00



Bagnato  
Terrain Meuble



### Argotal

**SPECIALIST FOR LOOSE TERRAINS.** Ideal tire for loose terrain, with cornering stability and increased side-grip. The open tread pattern allows for self-cleaning so you can push your riding limits through dust and loam.

**DER SPEZIALIST FÜR LOCKERE BÖDEN.** Idealer Reifen für den Einsatz auf weichen Böden, der sich durch Kurvenstabilität und erhöhten seitlichen Grip auszeichnet. Das offene Profildesign gewährleistet eine gute Selbstreinigung, sodass Sie auch bei Staub und Schlamm an Ihre Grenzen gehen können.

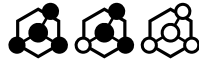

ARTICLE	EAN	ETRTO	DIMENSION	COLOR/SIDEWALL	TECHNOLOGY	WEIGHT	BAR	MAX.BAR	PRICE (€)
<b>Argotal 2.4</b>									
C0150684	4019238068016	60-584	27.5"   27.5x2.40	black/black fold. skin	Enduro/Soft Comp.	1080g	2,5	3,5	85,00
C0150686	4019238068078	60-622	29"   29x2.40	black/black fold. skin	Enduro/Soft Comp.	1160g	2,5	3,5	85,00
C0150689	4019238067972	60-584	27.5"   27.5x2.40	black/black fold. skin	Trail/Endurance Comp.	1000g	2,5	3,5	73,00
C0150691	4019238068030	60-622	29"   29x2.40	black/black fold. skin	Trail/Endurance Comp.	1040g	2,5	3,5	73,00
<b>Argotal 2.6</b>									
C0150685	4019238067910	65-584	27.5"   27.5x2.60	black/black fold. skin	Enduro/Soft Comp.	1220g	2,0	3,0	89,00
C0150688	4019238067958	65-622	29"   29x2.60	black/black fold. skin	Enduro/Soft Comp.	1275g	2,0	3,0	89,00
C0150690	4019238067897	65-584	27.5"   27.5x2.60	black/black fold. skin	Trail/Endurance Comp.	1100g	2,0	3,0	81,00
C0150692	4019238067934	65-622	29"   29x2.60	black/black fold. skin	Trail/Endurance Comp.	1200g	2,0	3,0	81,00



Asciutto  
Terrain Dur



### Xynotal

**SPECIALIST FOR HARDPACK AND DRY CONDITIONS.** Perfect for hardpack, rocky surfaces. With low rolling resistance and contact edges for improved traction and braking, you can enjoy a fast gravity ride with the confidence of continuous grip when you need it most.

**DER SPEZIALIST FÜR HARTEN UNTERGRUND UND TROCKENE BEDINGUNGEN.** Perfekt für harten Untergrund und felsige Oberflächen. Dank des geringeren Rollwiderstands und Kontaktflächen an den Kanten, für verbesserte Traktion und besseres Bremsverhalten, können Sie Ihre temporeichen Abfahrten genießen, immer mit der Gewissheit, dass Sie stets optimalen Grip haben, wenn Sie ihn wirklich brauchen.

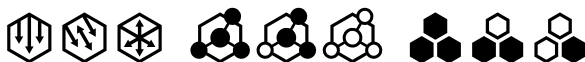

ARTICLE	EAN	ETRTO	DIMENSION	COLOR/SIDEWALL	TECHNOLOGY	WEIGHT	BAR	MAX.BAR	PRICE (€)
<b>Xynotal 2.4</b>									
C0150646	4019238063257	60-584	27.5"   27.5x2.40	black/black fold. skin	Trail/Endurance Comp.	1000g	2,5	3,5	73,00
C0150647	4019238063240	60-622	29"   29x2.40	black/black fold. skin	Trail/Endurance Comp.	1040g	2,5	3,5	73,00

4 NAMES, 5 PATTERNS, 1

# The all new G

CAS

TERRAIN

	<b>TRAIL</b>				<b>ENDURO</b>	
<b>HARD PACK</b>	27.5" X 2.4 <b>XY</b> XYNOTAL	29" X 2.4 <b>XY</b> XYNOTAL			27.5" X 2.4 <b>XY</b> XYNOTAL	29" X 2.4 <b>XY</b> XYNOTAL
	27.5" X 2.4 <b>Fr</b> <b>KR</b> KRYPTOTAL	29" X 2.4 <b>Fr</b> <b>KR</b> KRYPTOTAL			27.5" X 2.4 <b>Fr</b> <b>KR</b> KRYPTOTAL	29" X 2.4 <b>Fr</b> <b>KR</b> KRYPTOTAL
<b>MIXED</b>	27.5" X 2.4 <b>Re</b> <b>KR</b> KRYPTOTAL	27.5" X 2.6 <b>Re</b> <b>KR</b> KRYPTOTAL	29" X 2.4 <b>Re</b> <b>KR</b> KRYPTOTAL	29" X 2.6 <b>Re</b> <b>KR</b> KRYPTOTAL	27.5" X 2.4 <b>Re</b> <b>KR</b> KRYPTOTAL	27.5" X 2.6 <b>Re</b> <b>KR</b> KRYPTOTAL
<b>LOOSE</b>	27.5" X 2.4 <b>AR</b> ARGOTAL	27.5" X 2.6 <b>AR</b> ARGOTAL	29" X 2.4 <b>AR</b> ARGOTAL	29" X 2.6 <b>AR</b> ARGOTAL	27.5" X 2.4 <b>AR</b> ARGOTAL	27.5" X 2.6 <b>AR</b> ARGOTAL
<b>MUD</b>						

TERRAIN



HARDPACK MIXED LOOSE MUD

COMPOUND



SUPER SOFT SOFT ENDURANCE

INFINITE POSSIBILITIES

# Gravity Range

ING

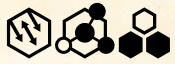

**DOWNHILL  
SOFT**



**DOWNHILL  
SUPER SOFT**



27.5" X 2.4

29" X 2.4

27.5" X 2.4

29" X 2.4

**XY**  
XYNOTAL

**XY**  
XYNOTAL

**XY**  
XYNOTAL

**XY**  
XYNOTAL

27.5" X 2.4

Fr

29" X 2.4

Fr

**KR**  
KRYPTOTAL

**KR**  
KRYPTOTAL

29" X 2.4

Re

29" X 2.6

Re

**KR**  
KRYPTOTAL

**KR**  
KRYPTOTAL

27.5" X 2.4

Re

29" X 2.4

Re

**KR**  
KRYPTOTAL

**KR**  
KRYPTOTAL

27.5" X 2.4

Re

29" X 2.4

Re

**KR**  
KRYPTOTAL

**KR**  
KRYPTOTAL

29" X 2.4

29" X 2.6

**AR**  
ARGOTAL

**AR**  
ARGOTAL

27.5" X 2.4

29" X 2.4

**AR**  
ARGOTAL

**AR**  
ARGOTAL

27.5" X 2.4

29" X 2.4

**AR**  
ARGOTAL

**AR**  
ARGOTAL

27.5" X 2.4

29" X 2.4

**HY**  
HYDROTAL

**HY**  
HYDROTAL

## RIDING



DOWNHILL



ENDURO



TRAIL

## CASING



DOWNHILL



ENDURO



TRAIL





## Cross King

### A FIRST CLASS ALL-ROUNDER WHICH ALSO PROVES ITSELF IN COMPETITIONS.

- versatile competition and trail tyre, sure footed in turns and comfortable
- good grip and available with various technologies
- smoothly rolling tyre that adapts to any terrain with its special tread

### EIN ERSTKLASSIGER ALLROUNDER, DER SICH AUCH GERN MAL IM WETTKAMPF BEWEIST.

- vielseitiger Wettkampf- und Tourenreifen mit sicherem Kurvenhalt und Fahrkomfort
- guter Grip und leises Abrollverhalten, mit verschiedenen Technologien verfügbar
- leichtläufiger Reifen, der sich mit seinem speziellen Profil jedem Untergrund anpasst



ARTICLE	EAN	ETRTO	DIMENSION	COLOR/SIDEWALL	TECHNOLOGY	WEIGHT	BAR	MAX.BAR	PRICE (€)
<b>Cross-King 2.2 ProTecton</b>									
C0101483	4019238798036	55-559	26x2.2	black skin foldable	ProTecton	590g	3,0	4,0	67,90
C0101465	4019238798050	55-584	27.5x2.2	black skin foldable	ProTecton	620g	3,0	4,0	67,90
C0101965	4019238071474	55-584	27.5x2.2	black/transp. fold.	ProTecton	630g	3,0	4,0	67,90
C0101471	4019238798043	55-622	29x2.2	black skin foldable	ProTecton	660g	3,0	4,0	67,90
C0101966	4019238071467	55-622	29x2.2	black/transp. fold.	ProTecton	670g	3,0	4,0	67,90
<b>Cross King 2.2 ShieldWall</b>									
C0150303	4019238797480	55-559	26x2.2	black skin foldable	ShieldWall System	700g	3,0	4,0	36,90
C0150291	4019238797503	55-584	27.5x2.2	black skin foldable	ShieldWall System	740g	3,0	4,0	36,90
C0150295	4019238797497	55-622	29x2.2	black skin foldable	ShieldWall System	790g	3,0	4,0	36,90
<b>Cross King 2.3 ProTecton</b>									
C0101463	4019238798364	58-584	27.5x2.3	black foldable	ProTecton	730g	2,8	3,8	67,90
C0101475	4019238798418	58-622	29x2.3	black foldable	ProTecton	770g	2,8	3,8	67,90
<b>Cross King 2.3 ShieldWall</b>									
C0150302	4019238798319	58-559	26x2.3	black foldable	ShieldWall System	730g	2,8	3,8	36,90
C0150290	4019238798296	58-584	27.5x2.3	black foldable	ShieldWall System	780g	2,8	3,8	36,90
C0150297	4019238798326	58-622	29x2.3	black foldable	ShieldWall System	830g	2,8	3,8	36,90
<b>Cross King 2.6 ShieldWall</b>									
C0150337	4019238003581	65-584	27.5x2.60	black skin foldable	ShieldWall System	920g	2,0	3,0	40,99
C0150502	4019238037258	65-622	29x2.60	black skin foldable	ShieldWall System	995g	2,0	3,0	40,99
<b>Cross-King 2.6 ProTecton</b>									
C0101384	4019238773606	65-584	27.5x2.6	black foldable	ProTecton	810g	2,0	3,0	89,99
<b>Cross-King 2.8 ShieldWall</b>									
C0150336	4019238003611	70-584	27.5x2.80	black skin foldable	ShieldWall System	1040g	1,8	2,8	40,99



### Mountain King

**HERO ON THE MOUNTAIN: THE PERFECT TRAIL COMPANION.**

- sure riding in hilly terrain and also optimal for the touring mountain bike
- superior grip from its continuous central tread and its grippy outer lugs
- the perfect companion for exploring the trails

**HELD AM BERG: PERFEKTER TOURENBEGLEITER MIT BODENHAFTUNG.**

- sicher im bergigen Gelände unterwegs und ebenso optimal auf dem Touren-Mountainbike
- viel Grip durch seine bissigen Mittel- und griffigen Außenstollen
- als All-Mountain-Reifen mit Enduro-Ambitionen der perfekte Begleiter für sportliche Ausfahrten



ARTICLE	EAN	ETRTO	DIMENSION	COLOR/SIDEWALL	TECHNOLOGY	WEIGHT	BAR	MAX.BAR	PRICE (€)
<b>Mountain King 2.3 ProTecton</b>									
C0101461	4019238798371	58-584	27.5x2.3	black skin foldable	ProTecton	730g	2,8	3,8	69,90
C0101469	4019238798432	58-622	29x2.3	black skin foldable	ProTecton	770g	2,8	3,8	69,90
<b>Mountain King III 2.3 ShieldWall</b>									
C0150301	4019238798333	58-559	26x2.3	black skin foldable	ShieldWall System	730g	2,8	3,8	36,99
C0150289	4019238798302	58-584	27.5x2.3	black skin foldable	ShieldWall System	770g	2,8	3,8	36,99
C0150294	4019238798340	58-622	29x2.3	black skin foldable	ShieldWall System	820g	2,8	3,8	36,99
<b>Mountain King 2.6/2.8 ShieldWall</b>									
C0150335	4019238003598	65-584	27.5x2.6	black skin foldable	ShieldWall System	935g	2,0	3,0	40,99
C0150334	4019238003628	70-584	27.5x2.8	black skin foldable	ShieldWall System	1020g	1,8	2,8	40,99
<b>Mountain King 2.6 ProTecton</b>									
C0101583	4019238003543	65-584	27.5x2.6	black foldable	ProTecton	810g	2,0	3,0	79,90



### Race King

**FOR THE SKILLED: A HEARTY TIRE THAT WANTS TO BE RACED.**

- impressive in cross-country races and marathons, for hardtails and full suspension race bikes
- low rolling resistance, a voluminous carcass and exemplary self-dampening qualities
- minimal tread: for dedicated cyclists, for those who have the hunger for speed

**FÜR KÖNNER: EIN KERNIGER WETTKAMPFTYP, DER SICH BEI RENNEN MESSEN WILL.**

- überzeugend bei Cross-Country-Rennen und im Marathon, für Hardtails und Race Fullys
- kommt mit geringem Rollwiderstand, einer voluminösen Karkasse und sehr guter Eigendämpfung daher
- wenig Profil: beste Voraussetzungen für Vielfahrer, die es drauf haben



ARTICLE	EAN	ETRTO	DIMENSION	COLOR/SIDEWALL	TECHNOLOGY	WEIGHT	BAR	MAX.BAR	PRICE (€)
<b>Race King 2.0 ShieldWall</b>									
C0150309	4019238797527	50-584	27.5x2.0	black foldable	ShieldWall System	630g	3,5	4,5	36,90
C0150307	4019238797534	50-622	29x2.0	black foldable	ShieldWall System	660g	3,5	4,5	36,90
<b>Race King 2.2 ProTaction</b>									
C0101486	4019238798111	55-559	26x2.2	black skin foldable	ProTaction	560g	3,0	4,0	67,90
C0101467	4019238798135	55-584	27.5x2.2	black skin foldable	ProTaction	590g	3,0	4,0	67,90
C0101962	4019238071504	55-584	27.5x2.2	black/transp. fold.	ProTaction	590g	3,0	4,0	67,90
C0101473	4019238798128	55-622	29x2.2	black skin foldable	ProTaction	620g	3,0	4,0	67,90
C0101963	4019238071498	55-622	29x2.2	black/transp. fold.	ProTaction	630g	3,0	4,0	67,90
<b>Race King 2.2 ShieldWall</b>									
C0150304	4019238797541	55-559	26x2.2	black skin foldable	ShieldWall System	660g	3,0	4,0	36,99
C0150292	4019238797565	55-584	27.5x2.2	black skin foldable	ShieldWall System	700g	3,0	4,0	36,99
C0150296	4019238797558	55-622	29x2.2	black skin foldable	ShieldWall System	740g	3,0	4,0	36,99



### Tubeless Ready

Our Tubeless Ready [TR] tyres can be used with tubes or sealant. Tyres and rims are designed in such a way that when used together they seal easily. For safety reasons only use wheels designed to be Tubeless Ready. TR tyres have an altogether lighter design. Their sidewalls are less permeable for air and are sealed with a special sealant, for example Conti RevoSealant.

Tubeless Ready Reifen können mit und ohne Schlauch verwendet werden. Um den Reifen ohne Schlauch zu nutzen muss er mit einem speziellen Dichtmittel versiegelt werden. Die revolutionäre Tubeless Ready Wulst ermöglicht eine einfache und unkomplizierte Montage des Reifens. Alle Mountainbike-Reifen von Continental in den Ausführungen ProTection und Performance sind Tubeless Ready. Für optimale Ergebnisse bei der Abdichtung und im Einsatz empfehlen wir die Verwendung des neuen Continental RevoSealant Dichtmittels.



### Suitable for E-Bikes

For our E-Bike tire we fall back on over 100 years' experience with moped and motorcycle tires. All of our city/trekking tires are rated to a standard speed of at least 25 km/h. Those tires marked e50 are also certified for S-Pedelecs. With their high quality structure, puncture protection is high and the rolling resistance is low offering protection from premature wear brought about by the additional driving force.

Geeignet für E-Bikes. Bei unserem E-Bike-Reifen greifen wir auf über 100 Jahre Erfahrung mit Moped- und Motorradreifen zurück. Alle unsere City- / Trekking-Reifen sind für eine Standardgeschwindigkeit von mindestens 25 km/h ausgelegt. Die mit e50 gekennzeichneten Reifen sind auch für S-Pedelecs zertifiziert. Durch ihre hochwertige Struktur ist der Pannenschutz hoch und der Rollwiderstand gering, was vor vorzeitigem Verschleiß durch die zusätzliche Antriebskraft schützt.



**Continental**



### ProTaction

**THE HARD WAY.** The ProTaction technology gives our tyres their perfect mix of fast rolling, grip and puncture protection. Four plies under the tread and three in the sidewalls make this possible. The whole tyre attains greater resilience and becomes less vulnerable to damage. Adheres well to the terrain, even on the toughest trails. BlackChili Compound ensures smooth rolling and the required grip. The revolutionary Tubeless Ready base enables the tyre to be mounted easily. Conti RevoSealant gives reliable sealing. Technology: BlackChili Compound; 3/180 TPI carcass; 50 x 40 TPI ProTaction weave.

**AUF DIE HARTE TOUR.** Die ProTaction-Technologie verleiht unseren Reifen ihre perfekte Mischung aus Leichtlauf, Grip und Pannenschutz. Bügelt sauber, selbst über die härtesten Trails. BlackChili Compound sorgt für den nötigen Leichtlauf und Grip. Der revolutionäre Tubeless-Ready-Fuß ermöglicht eine leichte und unkomplizierte Montage des Reifens. Conti Revo-Sealant dichtet zuverlässig ab. Technologie: BlackChili Compound; 3/180-TPI-Karkasse; 50 x 40 TPI-ProTaction-Gewebe.



### ShieldWall System

**TUBELESS READY AND PUNCTURE PROTECTION FOR RIDERS ON A BUDGET.** The ShieldWall system combines the optimum combination of high puncture protection and the low rolling resistance with low weight. This is made possible by an additional, all-round puncture protection layer, which consists of a finely woven cross fabric. This gives the tire a high resistance to punctures and damage. Despite its additional ply, the tire has a very good damping property and a high degree of flexibility to adapt perfectly to the ground. The revolutionary tubeless ready bead allows easy and uncomplicated mounting of the tire. For best results in sealing and in use, we recommend the use of the new Continental RevoSealant sealant.

**DAS SHIELDWALL SYSTEM VERBINDET DIE OPTIMALE KOMBINATION AUS HO-HEM PANNENSCHUTZ UND BESTEM LEICHTLAUF BEI NIEDRIGEM GEWICHT.** Möglich macht das eine zusätzliche, rundum laufende Pannenschutzlage, die aus einem fein gewobenen Kreuzgewebe besteht. Dadurch erhält der Reifen eine hohe Widerstandsfähigkeit gegen Durchstiche und Verletzungen. Trotz zusätzlicher Lage hat der Reifen sehr gute dämpfende Eigenschaften und besitzt hohe Flexibilität, um sich dem Untergrund perfekt anzupassen. Der revolutionäre Tubeless Ready Fuß ermöglicht eine leichte und unkomplizierte Montage des Reifens. Conti Revo-Sealant dichtet zuverlässig ab.



### Performance

**RELIABLE QUALITY.** PureGrip is the compound technology which we use exclusively for our Performance level series. The name speaks for itself - the combination of superior grip and longevity. A long lasting rubber mixture with a robust 60-TPI-Nylon carcass guarantees the highest durability. Tubeless Ready: reliable sealing with Conti RevoSealant. A strong aramide foldable bead ensures a secure fit to the rim. For ambitious hobby cyclists, a low-cost alternative to our Premium line. Technology: PureGrip Compound; Tubeless Ready; revolutionary Tubeless Ready base; robust and full sidewall rubber coating; 3/180 TPI carcass and sidewall with wafer design pattern.

**ZUVERLÄSSIGE QUALITÄT.** PureGrip ist die Mischungstechnologie, die wir exklusiv für unsere Performance-Qualitätsreihe verwenden. Der Name spricht für sich - die Kombination Grip und Langlebigkeit ist Programm. Die langlebige und haftungsstarke Gummimischung verspricht langes Fahrvergnügen eine robuste 60-TPI-Nylon-Karkasse gewährleistet beste Haltbarkeit. Tubeless Ready: zuverlässiges Abdichten mit Conti RevoSealant möglich. Ein starker Aramidfaltkern sorgt für festen Halt auf der Felge. Für ambitionierte Hobbysportler eine preiswerte Alternative zu unserer Premium-Linie. Technologie: PureGrip; Tubeless Ready; Revolution-Tubeless-Ready-Fuß; robuste und satte Seitenwandgummierung; 3/180-TPI-Karkasse; Seitenwand im Flag-Design.



# URBAN TOUR





### CONTACT Speed

**SPEED AND COMFORT, UNITED IN A TYRE.**

- the perfect choice for the city speedsters, single-speed bikes and fitness bikes
- double puncture protection, good grip and light-weight design
- the roughened slick tread speeds along on tarmac

**GESCHWINDIGKEIT UND KOMFORT, VEREINT IN EINEM REIFEN.**

- die perfekte Wahl für puristische Stadtflitzer, Singlespeed-Räder und Fitness-Bikes
- doppelte Pannenschutzlage, guter Grip und dabei leicht im Aufbau
- das angeraute und schnelle Slickprofil punktet vor allem auf Asphalt

### CONTACT Plus

**THE ULTIMATE COMBINATION.** An all-rounder on any type of road or path that enhances every bike. Thanks to the addition of puncture protection, nobody will be left behind with a flat tire. Together with the Hermetic Plus tube, it's an absolutely worry-free product.

**DIE ULTIMATIVE KOMBINATION.** Ein Allrounder für jede Art von Straße und Weg, der jedes Fahrrad aufwertet. Dank des zusätzlichen Pannenschutzes bleibt niemand mit einer Reifenpanne zurück. Zusammen mit dem Hermetic Plus Schlauch ist er ein absolut sorgenfreies Produkt.



ARTICLE	EAN	ETRTO	DIMENSION	COLOR/SIDEWALL	TECHNOLOGY	WEIGHT	BAR	MAX.BAR	PRICE (€)
<b>CONTACT Speed</b>									
C0101412	4019238774559	37-622	28x1 3/8x1 5/8	black wire skin	Double SafetySystemBreaker	500g	5,0	6,0	32,90
C0101416	4019238774504	42-622	700x42 C (40 C)	black wire skin	Double SafetySystemBreaker	590g	3,5	6,0	32,90
<b>CONTACT Plus</b>									
C0101002	4019238639964	47-559	26x1.75	black reflex wire skin	SafetyPlusBreaker	1040g	3,0	4,0	42,99
C0101004	4019238639940	32-622	28x1 1/4x1 3/4	black reflex wire skin	SafetyPlusBreaker	750g	5,0	6,0	42,99
C0101005	4019238639933	37-622	28x1 3/8x1 5/8	black reflex wire skin	SafetyPlusBreaker	980g	4,0	6,0	42,99
C0101006	4019238639926	42-622	28x1.6	black reflex wire skin	SafetyPlusBreaker	1050g	3,5	5,0	42,99





**RIDE Tour**

**TIME FOR A RIDE TRUSTED COMPANION ON YOUR REGULAR RIDES.**

- tarmac, unsurfaced park paths, urban surroundings - the right choice for the city cyclist on their daily ride
- features a puncture resistant carcass and an extra layer of rubber for enduring mileage
- available in a large range of colours and sizes

**DER REIFEN IST AUF JEDEM UNTERGRUND ZU HAUSE, EIN ECHTER ALLROUNDER.**

- durchgängige Mittellauffläche bietet gleichzeitig gute Rolleigenschaften und genügend Traktion bei Kurvenfahrten
- zuverlässiger Pannenschutz durch Extra Puncture Belt
- widerstandsfähige Karkasse und langlebiger Laufstreifen überzeugen regelmäßig bei Ausfahrten



ARTICLE	EAN	ETRTO	DIMENSION	COLOR/SIDEWALL	TECHNOLOGY	WEIGHT	BAR	MAX.BAR	PRICE (€)
<b>RIDE Tour</b>									
C0101148	4019238693553	47-559	26x1.75	black wire skin	Extra Puncture Belt	780g	3,0	4,0	21,99
C0101151	4019238693522	28-622	700x28C (700C)	black wire skin	Extra Puncture Belt	540g	5,0	5,5	21,99
C0101153	4019238693508	32-622	700x32C	black wire skin	Extra Puncture Belt	640g	5,0	5,5	21,99
C0101155	4019238693485	37-622	700x35C	black wire skin	Extra Puncture Belt	690g	4,0	5,0	21,99
C0101157	4019238693478	42-622	700x42C (40C)	black wire skin	Extra Puncture Belt	790g	3,5	4,5	21,99



**SafetyPlus Breaker**

**THE ANTI-PUNCTURE SPECIALIST**

Specially designed for e-bikes up to 50 km/h, we have combined our SafetySystem Breaker with a highly flexible natural rubber. The result is an extremely cut and puncture resistant breaker ply which has a low rolling resistance thanks to its high elasticity. This helps saving battery life and the environment. High acceleration torques and fast speeds in turns are easily absorbed by the breaker. The specialist for fast e-bikes and rental bikes.

**SAFETYPLUS BREAKER - DER SPEZIALIST UNTER DEN BREAKERN**

Speziell für E-Bikes bis 50 km/h haben wir unseren Safety-System-Breaker mit einem hochflexiblen Kautschuk kombiniert. Das Resultat ist ein extrem schnitt- und stichfester Breaker, der dank seiner hohen Elastizität einen geringen Rollwiderstand aufweist. Das schont die Umwelt und den Akku. Hohe Beschleunigungsmomente sowie schnelle Kurvengeschwindigkeiten steckt der Breaker problemlos weg. Der Spezialist für schnelle E-Bikes und Räder von Verleihstationen.

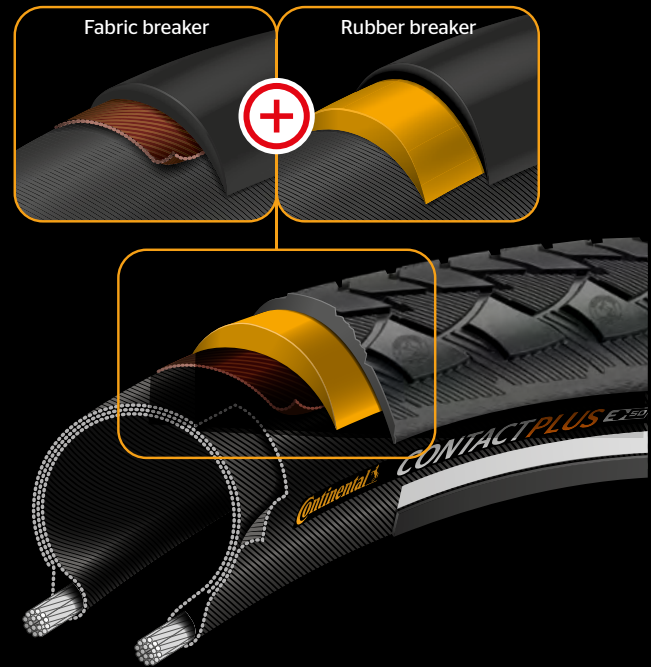

Up to **30% higher puncture protection\*** against glass and sharp flints!

\* Benchmark test: Piercing (blade) test measuring force required, Zedler Institute, 2016  
- further details of the test: [www.continental-tires.com/bicycle/technology](http://www.continental-tires.com/bicycle/technology)

Bis zu **30 % höherer Pannenschutz\*** gegen das Eindringen von Scherben und spitzen Steinen!

\* Vergleichstest Durchstichskraft Klinge durch Zedler Institut 2016  
mehr Infos zum Test unter [www.continental-reifen.de/fahrrad/technologie](http://www.continental-reifen.de/fahrrad/technologie)

**EXTRA PunctureBelt**

Anyone looking for a reliable everyday companion will go for a tire with EXTRA PunctureBelt. This rugged rubber breaker, combined with the rubber-reinforced sidewalls of the tire, ensures a high level of puncture protection and sidewall abrasion. Where durability is the main focus, there is also a solid tire version.

Wer einen zuverlässigen Begleiter im Alltag sucht, greift zu einem Reifen mit EXTRA PunctureBelt. Dieser robuste Gummibreaker, kombiniert mit den gummiverstärkten Seitenwänden des Reifens, gewährleistet einen hohen Pannen- und Anscheuerungsschutz. Kommt in soliden Reifen mit klarem Fokus auf Haltbarkeit zum Einsatz.



# ACCESSORIES



Small details make the difference. Be it seating the tyre on the rim, or repair jobs, on the road or at home, your tyres get the best service and support. In the next page you will find useful accessories to help make the practical aspects of your sport as hassle-free as possible. From the correct tube, the right rims, to the matching tyre lever and an effective sealant, we have something for your next project.

Die Details machen den Unterschied. Ob zur Montage oder Reparatur, unterwegs oder zu Hause: Ihre Reifen verdienen den besten Service und Support. Auf den folgenden Seiten finden Sie praktische Helfer, die Sie dabei unterstützen, Ihren Sport so komfortabel wie möglich ausüben zu können. Vom passenden Schlauch über Felgenbänder bis zum Reifenheber und einer effektiv arbeitenden Dichtmilch - wir haben da was für Ihr nächstes Projekt.

ARTICLE	EAN	DESCRIPTION	ETRTO	DIMENSION	PRICE (€)
<b>MTB Bicycle Tubes</b>					
C0181631	4019238556711	<b>MTB 26</b>	47-559 > 62-559	S42	8,99
C0182311	4019238619591	<b>MTB 27.5</b>	47-584 > 62-584	S42	8,99
C0180015	4019238008067	<b>MTB 27.5</b>	65-584 > 70-584	S42	10,99
C0182181	4019238557084	<b>MTB 28 / 29 inch</b>	47-622 > 62-662	S42	8,99
C0182191	4019238557091	<b>MTB 28 / 29 inch</b>	47-622 > 62-662	S60	9,99
<b>Tour Bicycle Tubes</b>					
C0182031	4019238556940	<b>Tour 28 all</b>	32-622 > 47-622	S42	8,99
<b>Cross Bicycle Tubes</b>					
C0181941	4019238556872	<b>Cross Tube 28</b>	32-622 > 47-622	S42	8,99
C0181951	4019238556889	<b>Cross Tube 28</b>	32-622 > 47-622	S60	9,99
<b>Race Bicycle Tubes</b>					
C0181781	4019238556780	<b>Race 28</b>	20-622 > 25-630	S42	8,99
C0181791	4019238556797	<b>Race 28</b>	20-622 > 25-630	S60	9,99
C0180000	4024066568133	<b>Race 28</b>	20-622 > 25-630	S80	10,99
C0181821	4019238556803	<b>Race 28 Light</b>	20-622 > 25-630	S42	10,99
C0181831	4019238556810	<b>Race 28 Light</b>	20-622 > 25-630	S60	12,99
C0181871	4019238556827	<b>Race 28 Light</b>	20-622 > 25-630	S80	13,99
C0181881	4019238556834	<b>Race 28 Supersonic</b>	20-622 > 25-630	S42	19,50
C0181891	4019238556841	<b>Race 28 Supersonic</b>	20-622 > 25-630	S60	19,50
C0181921	4019238556858	<b>Race 28 Wide</b>	20-622 > 25-630	S42	8,99
C0181931	4019238556865	<b>Race 28 Wide</b>	20-622 > 25-630	S60	9,99



ARTICLE	EAN	DESCRIPTION	WEIGHT	PRICE (€)
<b>Tubular kit</b>				
C0149091	4019238105322	Rim cement for aluminium	tube 25g	5,50
C0149092	4019238105339	Rim cement for aluminium	can 350g	33,90
C0140016	4024066441405	Rim cement for carbon rims	tube 25g	5,50
C0140017	4024066441412	Rim cement for carbon rims	can 200g	24,90
<b>Tube bag</b>				
C0100388	4024066508061	Tube bag with Race 28 S42 tube and 2 tire lever race	160g	12,99
C0101026	4024066653112	Tube bag with MTB 29 tube S42 and 2 tire levers MTB	320g	12,99
<b>Sealant</b>				
C0140044	4019238558913	Continental RevoSealant	240ml	14,90
C0140050	4019238585278	Continental RevoSealant	1.000ml	38,90
<b>Valve extension</b>				
C0149690	4019238105353	Exchangeable presta valve insert (bag of 10 pcs)	10 pcs	10,00
C0140030	4024066549170	Valve extension for presta valve aluminium 30mm, 2pcs	30mm	14,90
C0140032	4024066549194	Valve extension for presta valve aluminium 40mm, 2pcs	40mm	14,90
C0140034	4024066549217	Valve extension for presta valve aluminium 60mm, 2pcs	60mm	15,90

# BROOKS

18 ENGLAND 66



BROOKS  
18 ENGLAND 66



**BROOKS ENGLAND**



# **Cambium saddles**



IMMEDIATE COMFORT

**All Rides. All Roads. All Weathers.**



**Weatherproof, durable, and comfortable straight out of the box, Brooks England Cambium saddles combine the timeless commitment to quality with modern materials and techniques.**

Ready to ride for all weathers and roads, the flexibility of a natural rubber top on the simple construction of our cambium saddle has been designed to move with you on the journey. Made to the same timeless standards of design that Brooks England saddles are renowned for, the remarkable properties of natural rubber are ready to inspire a new generation of intrepid riders.

**Die wetterfesten, langlebigen und komfortablen Brooks England Cambium Sättel vereinen den immerwährenden Anspruch an Qualität mit modernen Materialien und Fertigungstechniken.**

Ready to ride - bei jedem Wetter, auf jedem Untergrund. Die Flexibilität einer Satteldecke aus natürlichem Gummi gepaart mit der einfachen Konstruktion unseres Cambium-Sattels, entworfen, um sich mit Ihnen auf Ihren Reisen zu bewegen. Hergestellt nach den gleichen, zeitlosen Design-Standards, für die die Sättel von Brooks England bekannt sind, inspirieren die bemerkenswerten Eigenschaften des Kautschuks eine neue Generation begeisterter Radfahrer.

UV, Abrasion Resistant,  
Waterproof Nylon Cover.

UV-beständiger, abriebfester,  
wasserdichter Nylonbezug.



Durable Anodised  
Aluminium Rivets.

Widerstandsfähige Nieten  
aus eloxiertem Aluminium.

Vulcanised Natural Rubber offers  
a unique level of comfort.  
Vulkanisierter Naturkautschuk bietet ein  
einzigartiges Maß an Komfort.



Nose-piece and saddleplate in  
Fibreglass Reinforced Nylon.

Nasenstück und Sattelplatte aus  
glasfaserverstärktem Nylon.



**45°**  
RIDING POSITION

**C13 145mm**  
L275 x W145 x H55 mm



**C13 Carved 145mm**  
L275 x W145 x H55 mm



C13 DETAILS

145 MM



158 MM

ARTICLE	UPC/EAN	MODEL	TOP	STRUCTURE	WEIGHT	PRICE (€)
C203M00A06300	190445015353	<b>C13 145mm</b>	Black	Carbon Frame	295g	200
C203MCOA06300	190445015391	<b>C13 Carved 145mm</b>	Black	Carbon Frame	280g	200



**45°**  
RIDING POSITION

**C13 158mm**  
L275 x W158 x H55 mm



**C13 Carved 158mm**  
L275 x W158 x H55 mm



**C13 DETAILS**

NYLON TOP

VULCANISED NATURAL RUBBER

7X9 MM CARBON FRAME



ARTICLE	UPC/EAN	MODEL	TOP	STRUCTURE	WEIGHT	PRICE (€)
C203W00A06300	190445016305	<b>C13 158mm</b>	Black	Carbon Frame	310g	200
C203WC0A06300	190445016312	<b>C13 Carved 158mm</b>	Black	Carbon Frame	295g	200



**45°**  
RIDING POSITION

**C15**  
L283 x W140 x H52 mm



**C15 Carved**  
L283 x W140 x H52 mm



C15 DETAILS

STANDARD



CARVED

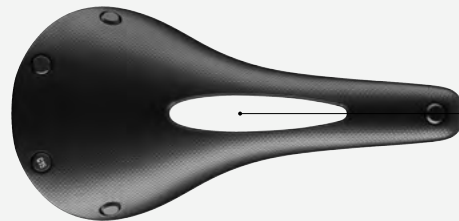

ARTICLE	UPC/EAN	MODEL	TOP	STRUCTURE	WEIGHT	PRICE (€)
C205000A06300	190445013861	<b>C15</b>	Black	Nose-piece and Saddleplate in Fibreglass Reinforced Nylon & Steel Rail	450g	130
C205C00A06300	190445013878	<b>C15 Carved</b>	Black	Nose-piece and Saddleplate in Fibreglass Reinforced Nylon & Steel Rail	432g	130



**60°**  
RIDING POSITION

**C17**  
L283 x W164 x H52 mm



**C17 Carved**  
L283 x W164 x H52 mm



**C17 CARVED DETAILS**

STEEL RAIL



NOSE-PIECE AND SADDLEPLATE  
IN FIBREGLASS REINFORCED NYLON

ARTICLE	UPC/EAN	MODEL	TOP	STRUCTURE	WEIGHT	PRICE (€)
C201000A06300	190445013847	<b>C17</b>	Black	Nose-piece and Saddleplate in Fibreglass Reinforced Nylon & Steel Rail	464g	130
C201C00A06300	190445013854	<b>C17 Carved</b>	Black	Nose-piece and Saddleplate in Fibreglass Reinforced Nylon & Steel Rail	446g	130



**60°**  
RIDING POSITION

**NEW COLOR**

**C17 Colored Top**  
L283 x W164 x H52 mm



**C17 Colored Top**  
L283 x W164 x H52 mm



**C17 Colored Top**  
L283 x W164 x H52 mm



**C17 Colored Top**  
L283 x W164 x H52 mm

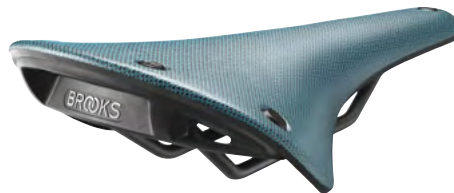

ARTICLE	UPC/EAN	NEW	MODEL	NYLON TOP	STRUCTURE	WEIGHT	PRICE (€)
C201000A06305	8021890552440	<b>NEW</b>	<b>C17</b>	Brown	Nylon Top, Nose-Piece and Saddleplate in Fibreglass Reinforced Nylon & Steel Rail	464g	130
C201000A00401	190445017555			Mud Green		464g	130
C201000A06317	190445016275			Bronze Orange		464g	130
C201000A06354	190445016282			Octane		464g	130

**NEW**

**C17 Carved Colored Top**  
L283 x W164 x H52 mm



**NEW**

**C17 Carved Colored Top**  
L283 x W164 x H52 mm



**NEW**

**C17 Carved Colored Top**  
L283 x W164 x H52 mm



**NEW**

**C17 Carved Colored Top**  
L283 x W164 x H52 mm



ARTICLE	UPC/EAN	NEW	MODEL	NYLON TOP	STRUCTURE	WEIGHT	PRICE (€)
C201C00A06305	8021890588111	<b>NEW</b>	<b>C17 Carved</b>	Brown	Nose-piece and Saddleplate in Fibreglass Reinforced Nylon & Steel Rail	446g	130
C201C00A00401	8021890588104	<b>NEW</b>		Mud Green		446g	130
C201C00A06317	8021890588128	<b>NEW</b>		Bronze Orange		446g	130
C201C00A06354	8021890588135	<b>NEW</b>		Octane		446g	130





**60°**  
RIDING POSITION

**C17 Special**  
ORGANIC COTTON  
L283 x W164 x H52 mm



**NEW COLOR**

**C17 Special**  
ORGANIC COTTON  
L283 x W164 x H52 mm



**NEW COLOR**

**C17 Special**  
ORGANIC COTTON  
L283 x W164 x H52 mm

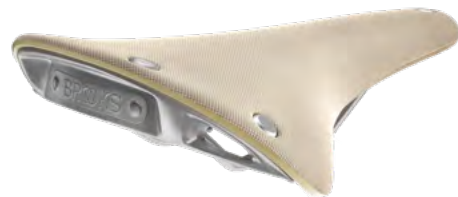

ARTICLE	UPC/EAN	NEW	MODEL	ORGANIC TOP	STRUCTURE	WEIGHT	PRICE (€)
C211000A06001	190445010273			Black/Natural Rubber		436g	160
C211000A56000	190445016329	<b>NEW</b>	<b>C17 Special</b>	Black/Black Rubber with Copper Rivets	Vulcanised Rubber & Organic Cotton Top, Nose-Piece and saddleplate in Aluminium Structure & Tubular Steel Rails	436g	160
C211000A06015	190445002766	<b>NEW</b>		Organic (Aluminium Frame) Natural/Natural Rubber		436g	160



**90°**  
RIDING POSITION

**C19**  
L275 x W184 x H57 mm



**C19 Carved**  
L275 x W184 x H57 mm



**C19 CARVED DETAILS**



ARTICLE	UPC/EAN	MODEL	TOP	STRUCTURE	WEIGHT	PRICE (€)
C209000A06300	190445013885	<b>C19</b>	Black	Nose-piece and Saddleplate in Fibreglass Reinforced Nylon & Steel Rail	490g	130
C209C00A06300	190445013892	<b>C19 Carved</b>	Black	Nose-piece and Saddleplate in Fibreglass Reinforced Nylon & Steel Rail	473g	130

# C67

CLASSIC EXTRA WIDE PROFILE FOR STABILITY  
AND COMFORT IN AN UPRIGHT CYCLING POSITION

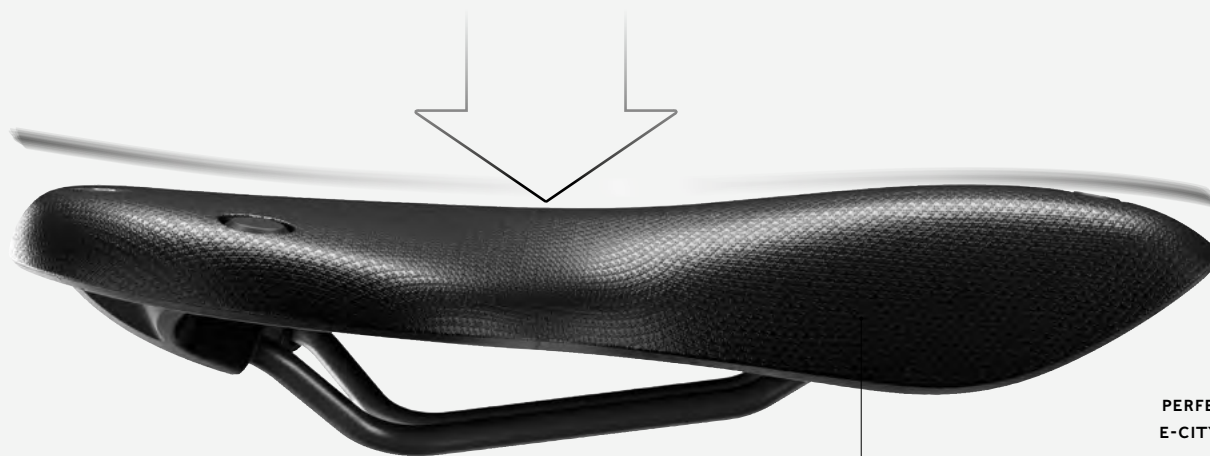

PERFECT ALSO FOR  
E-CITY AND CARGO

PERFECT FOR CITY / TREKKING  
(COMMUTER & TOURING)

## Our widest Cambium for upright urban cycling

The C67 is designed with the commuter, urban cyclist and casual tourer in mind and is perfect for cycling in all weathers in the upright riding position. Comfortably crafted from vulcanised natural rubber, the C67 moves with you for long-lasting support that requires no break-in period. Offering stability thanks to the wider rear part of the saddle, curved shape and flexible rubber base, the C67 provides maximum control during E-bike acceleration. Underneath, a fan-like structure made from fibreglass-reinforced nylon adds resistance against stress and vibrations while a smart rubber grip on the internal backplate guarantees a solid and stable grasp when walking with your electric, cargo or Dutch-style bike.

## Unser breiterster Cambium Sattel – für aufrechtes Radfahren in der Stadt

Der C67 wurde für Pendler, Stadtrader und Gelegenheits-Tourer entwickelt – und ist der perfekte Partner zum Radfahren bei jedem Wetter und zum Radfahren in einer möglichst aufrechten Sitzposition. Der C67 ist aus vulkanisiertem Naturkautschuk gefertigt und passt sich Ihren Bewegungen an. Das Ergebnis ist lang anhaltender Komfort – und das ganz ohne Einfahrzeit. Dank des breiteren hinteren Sattel-Teils, der geschwungenen Form und der flexiblen Gummibasis bietet der C67 darüber hinaus Stabilität und maximale Kontrolle bei der Beschleunigung eines E-Bikes. Und an seiner Unterseite sorgt eine fächerartige Struktur aus glasfaserverstärktem Nylon für zusätzliche Widerstandsfähigkeit gegen Belastungen und Vibrationen. Praktisch: Ein smarterer Gummigriff an der inneren Rückenplatte garantiert einen soliden und stabilen Halt, wenn Sie Ihr Elektro-, Cargo- oder Hollandrad einmal schieben bzw. tragen müssen.



**90°**  
RIDING POSITION

**C67**

L268 x W200 x H59 mm



The C67 features a wider rear area for more comfort in the upright position with a larger nose for added stability whilst riding.

The saddle top is made from 100% vulcanized rubber that guarantees the unique Brooks hammock effect for a natural seat offering flexibility and supporting the ischiatic bones.

**E-Shape:** the hammock effect of the natural rubber top is enhanced by an elevated rear section to prevent backward sliding with a more prominent nose for stability whilst riding.

**E-Grip:** a rubberised grip element on the internal back for easy and secure manoeuvring of the bike whilst on foot.

Der C67 verfügt über einen breiteren hinteren Bereich für mehr Komfort in der aufrechten Sitzposition und eine größere Nase für zusätzliche Stabilität während der Fahrt. Das Satteloberteil besteht aus 100% vulkanisiertem Gummi, das den einzigartigen Brooks-Hängematteneffekt für eine natürliche Sitzhaltung garantiert, die Flexibilität bietet und die Sitzbeinhöcker unterstützt.

**E-Shape:** Der Hängematteneffekt des Naturkautschuks wird durch einen erhöhten hinteren Teil verstärkt, um ein Rückwärtsrutschen zu verhindern, mit einer ausgeprägteren Nase für mehr Stabilität während des Fahrens.

**E-Grip:** ein gummiertes Griffelement auf der hinteren Innenseite für einfaches und sicheres Manövrieren des Fahrrads auch zu Fuß.

**C67 DETAILS**

VULCANISED NATURAL RUBBER SADDLE TOP,  
UV + ABRASION RESISTANT WATERPROOF  
NYLON TOP & FLEXIBLE SURFACE

METAL LOGO PLAQUE

WIDE SURFACE 200MM WIDTH



INNOVATIVE FAN STRUCTURE  
IN FIBREGLASS REINFORCED NYLON

RUBBERISED GRIP FOR STRONG  
AND STABLE HOLD

ARTICLE	UPC/EAN	MODEL	TOP	STRUCTURE	WEIGHT	PRICE (€)
SCM67NYA00000	190445017562	<b>C67</b>	Black	Nylon Top, Nose-Piece and Saddleplate in Fibreglass Reinforced Nylon & Steel Rail	485g	130

# BAR TAPE & GRIPS

## FIT FOR CAMBIUM SADDLES

Thermoplastic Rubber Material with UV + Abrasion-Resistant Waterproof Nylon on the Top and Ergonomic Grooves on the Underside.

Thermoplastisches Gummimaterial mit UV- und abriebfestem, wasserdichtem Nylon auf der Oberseite und ergonomischen Rillen an der Unterseite.



Brooks Bar Tape and Grips utilise natural and high quality materials, to offer superior control and maximum comfort on all contact points. Durable and versatile they are the perfect complement to any Brooks Saddle, from riding in the city to long distance travel.

Die Lenkerbänder und Griffe von Brooks bestehen aus natürlichen und hochwertigen Materialien, um eine hervorragende Kontrolle und maximalen Komfort an allen Kontaktpunkten zu bieten. Widerstandsfähig und vielseitig sind sie die perfekte Ergänzung zu jedem Brooks-Sattel, sowohl für Fahrten in der Stadt als auch für Reisen über lange Strecken.

**Ergonomic Rubber Grips**

130/130, 130/100 or 100/100 mm



ERGONOMIC COMFORT



HARD-WEARING



UNIQUE PREMIUM DETAILS



130/130 mm



130/100 mm



100/100 mm

**Cambium Rubber Grips**

130/130 or 130/100



COMFORTABLE TO THE TOUCH



HARD-WEARING



ADJUSTABLE



**NEW**

130/130 mm

130/100 mm

ARTICLE	UPC/EAN	NEW	MODEL	COLOR	DESCRIPTION	PRICE (€)
CSG6LLOA01000	8021890569912		<b>Ergonomic Rubber Grips</b>	Black	130/130 mm	60
CSG6LSOA01000	8021890569936			Black	130/100 mm	60
CSG6SSOA01000	8021890569950			Black	100/100 mm	60
CSG5LLOA01000	8021890569851		<b>Cambium Rubber Grips</b>	Black	130/130 mm	45
CSG5LLOA16015	8021890569868			Natural	130/130 mm	45
CSG5LSOA01000	8021890569875			Black	130/100 mm	45
CSG5LSOA16015	8021890569882	<b>NEW</b>		Natural	130/100 mm	45

## Cambium Rubber Bar Tape

Textured 3mm Comfort Padding



COMFORTABLE  
TO THE TOUCH



HARD-WEARING



ALL-SURFACE  
ABSORPTION

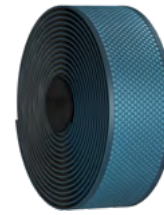
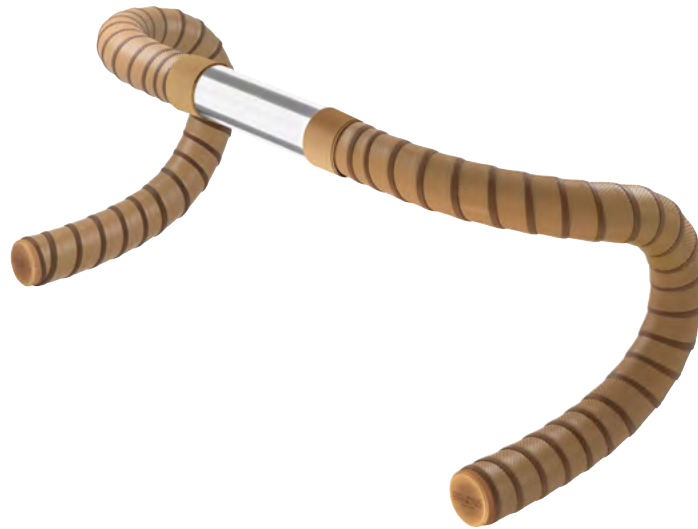

ARTICLE	UPC/EAN	MODEL	COLOR	DESCRIPTION	PRICE (€)
CT03000A16100	8021890569981	<b>Cambium Rubber Bar Tape</b>	Black	Textured 3mm Comfort Padding	45
CT03000A16115	8021890570017		Natural/Rubber		45
CT03000A16105	8021890569998		Brown		45
CT03000A10401	8021890569974		Mud Green		45
CT03000A16117	8021890570024		Bronze Orange		45
CT03000A16154	8021890570031		Octane		45





# MATCHING OPPORTUNITIES

FOR CAMBIUM RANGE

C17



C17 Special  
ORGANIC COTTON



C67



**C67**  
L268 x W200 x H59 mm

**Ergonomic  
Rubber Grips**  
130/130, 130/100 or 100/100 mm

C17 Carved  
Colored Top

BROWN



C17 Carved  
Colored Top

MUD GREEN



C17 Carved  
Colored Top

BRONZE ORANGE



C17 Carved  
Colored Top

OCTANE



**C17 Carved**  
L283 x W164 x H52 mm

**NEW**

**Cambium  
Rubber Grips**  
130/130 or 130/100

**Cambium  
Rubber Bar Tape**  
Textured 3 mm Comfort Padding



# **Leather saddles**

NATURALLY TIMELESS

Made by Hand. **Shaped by You.**



**Carefully crafted in our Smethwick, England factory and shaped by the journeys of countless riders around the world, providing customised comfort for over 150 years.**

Handcrafted from premium vegetable-tanned leather, each Brooks England leather saddle is naturally comfortable and supple enough to mould to an individual rider's body shape. They provide lifelong comfort and durability and a truly natural approach to support for cyclists. Refined and improved since the original 19th century patents, Brooks England saddles have achieved iconic status, with qualities proven by generations of riders. Each saddle is made by passionate craftspeople from the highest quality leather, selected, moulded, and finished by hand, and guaranteed for 10 years after purchase.

**Mit Liebe zum Detail in unserem Werk in Smethwick, England, hergestellt und von den Touren unzähliger Radfahrer auf der ganzen Welt geprägt – für maßgeschneiderten Komfort seit über 150 Jahren.**

Jeder Brooks England Ledersattel wird aus hochwertigem, pflanzlich gegerbtem Leder handgefertigt und ist von Natur aus bequem und geschmeidig genug, um sich an die individuelle Körperform des jeweiligen Fahrers anzupassen. Die Brooks Ledersättel bieten lebenslangen Komfort und Langlebigkeit – und darüber hinaus einen absolut natürlichen Ansatz zur Unterstützung von Radfahrern. Auf der Basis der ursprünglichen Patente aus dem 19. Jahrhundert stetig verfeinert und verbessert, haben die Sättel von Brooks England Kultstatus erreicht – und sich mit ihren Eigenschaften bei Generationen von Fahrern bewährt. Jeder Sattel wird von leidenschaftlichen Handwerkern aus hochwertigem Leder hergestellt, von Hand ausgewählt, geformt und fertiggestellt und hat eine Garantie von 10 Jahren nach dem Kauf.



The leather top suspended over the metal frame creates a hammock effect and allows natural movement.

Die über den Metallrahmen gespannte Lederfläche erzeugt einen Hängematteneffekt und ermöglicht eine natürliche Bewegungsfreiheit.

The unique leather top will mould and shape to your body over time offering supreme comfort.

Das einzigartige Lederoberteil passt sich mit der Zeit an Ihre Körperform an und bietet bestmöglichen Komfort.

Distinctive side stamps identify our iconic models.

Charakteristische Stempel auf der Seite kennzeichnen unsere klassischen Modelle.

Our durable copper rivets are hand hammered and finished by skilled craftsmen.

Unsere widerstandsfähigen Kupfernieten werden von erfahrenen Handwerkern von Hand gehämmert und bearbeitet.

The iconic Brooks backplate has been a hallmark of quality for over 150 years.

Die typische Brooks-Backplate ist seit über 150 Jahren ein Markenzeichen für Qualität.



**45°**  
RIDING POSITION

**Swift**

L272 x W150 x H72 mm



**Swallow**

L285 x W153 x H62 mm



SWIFT DETAILS

HAND FINISHED COPPER RIVETS



A CLASSIC SLIM PROFILE LEATHER TOP  
FOR A FORWARD RIDING POSITION

ARTICLE	UPC/EAN	MODEL	LEATHER TOP	METAL STRUCTURE	WEIGHT	PRICE (€)
B360H00A17202	831273006037	<b>Swift</b>	Black	Chrome Steel Rail & Hand Hammered Copper Rivets	510g	190
B360H00A17203	831273006044		Honey		510g	190
B360H00A17205	831273006051		Antique Brown		510g	190
B354000A17202	831273006006	<b>Swallow</b>	Black	Chrome Steel Rail	490g	190
B354000A17203	831273006013		Honey		490g	190
B354000A17205	831273006020		Antique Brown		490g	190



**45°**  
RIDING POSITION

**B17 Narrow**

L279 x W151 x H70 mm



**B17 NARROW DETAILS**

**ROBUST STEEL FRAME  
AND HARDWARE**



**THE CLASSIC B17 SHAPE BUT  
WITH A NARROWER PROFILE**

ARTICLE	UPC/EAN	MODEL	LEATHER TOP	METAL STRUCTURE	WEIGHT	PRICE (€)
B214000A07202	831273005511		Black		528g	150
B214000A07203	831273006402	<b>B17 Narrow</b>	Honey	Black Steel Rail	528g	150
B214000A07205	831273005528		Antique Brown		528g	150





**60°**  
RIDING POSITION

**B17**

L275 x W175 x H65 mm



**B17 Short**

L242 x W176 x H58 mm



**B17 DETAILS**

CLASSIC B17  
LEATHER PROFILE



DURABLE STEEL RIVETS  
AND FINISHINGS

ARTICLE	UPC/EAN	MODEL	LEATHER TOP	METAL STRUCTURE	WEIGHT	PRICE (€)
B211000A07202	831273005245	<b>B17</b>	Black	Black Steel	535g	150
B211000A07203	831273005702		Honey		535g	150
B211000A07205	831273006136		Antique Brown		535g	150
B211D00A07202	831273005252	<b>B17 Short</b>	Black	Black Steel	460g	150
B211D00A07203	831273005726		Honey		460g	150
B211D00A07205	831273006396		Antique Brown		460g	150



**60°**  
RIDING POSITION

**B17 Carved**

L 275 x W 175 x H 65 mm



**B17 Softened**

L 275 x W 175 x H 65 mm



**B17 CARVED DETAILS**

CLASSIC B17  
LEATHER PROFILE

ERGONOMIC CUT-OUT  
FOR PRESSURE RELIEF

DURABLE STEEL RIVETS  
AND FINISHINGS

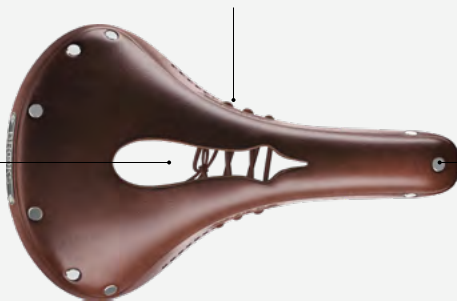

ARTICLE	UPC/EAN	MODEL	LEATHER TOP	METAL STRUCTURE	WEIGHT	PRICE (€)
B211ILOA07202	831273006105		Black		520g	150
B211ILOA17203	831273006327	<b>B17 Carved</b>	Honey	Chrome Steel	520g	150
B211ILOA17205	831273006334		Antique Brown		520g	150
B211PLOA07210	831273005894	<b>B17 Softened</b>	Dark Tan	Black Steel	530g	150



**60°**  
RIDING POSITION

**B17 Special**

L275 x W175 x H65 mm



**B17 Special Titanium**

L275 x W175 x H65 mm



**B17 SPECIAL TITANIUM DETAILS**

LIGHTWEIGHT, DURABLE AND  
VIBRATION-REDUCING TITANIUM FRAME



HAND-FINISHED, ULTRA-DURABLE  
PREMIUM COPPER RIVETS

HAND-CHAMFERED  
LEATHER DETAIL

ARTICLE	UPC/EAN	MODEL	LEATHER TOP	METAL STRUCTURE	WEIGHT	PRICE (€)
B211000A17202	831273005719	<b>B17 Special</b>	Black	Copper Steel Rail & Hand Hammered Copper Rivets	540g	190
B211000A17203	831273005269		Honey		540g	190
B211000A17205	831273006167		Antique Brown		540g	190
B211000A27202	831273005207	<b>B17 Special Titanium</b>	Black	Titanium Rail & Hand Hammered Copper Rivets	410g	260



**60°**  
RIDING POSITION

**Flyer**

L275 x W175 x H87 mm



**NEW COLORS**

**Flyer Short**

L242 x W176 x H86 mm



FLYER DETAILS

CLASSIC FLYER  
LEATHER PROFILE

STEEL COILS FOR ENHANCED  
RIDE COMFORT AND SHOCK ABSORPTION



DURABLE STEEL FRAME  
AND CONSTRUCTION

ARTICLE	UPC/EAN	NEW	MODEL	LEATHER TOP	METAL STRUCTURE	WEIGHT	PRICE (€)
B396H00A07202	831273005160			Black		860g	160
B396H00A07203	831273005177		<b>Flyer</b>	Honey	Black Steel	860g	160
B396H00A07205	831273006440			Antique Brown		860g	160
B396D00A07202	831273005184			Black		800g	160
B396D00A07203	831273005191	<b>NEW</b>	<b>Flyer Short</b>	Honey	Black Steel	800g	160
B396D00A07205	831273006457	<b>NEW</b>		Antique Brown		800g	160



**60°**  
RIDING POSITION

**Flyer Carved**

L275 x W175 x H87 mm



**Flyer Softened**

L275 x W175 x H87 mm



FLYER SOFTENED DETAILS

SUSPENDED FRAME FOR IMPROVED COMFORT AND SHOCK ABSORPTION



PRE-CONDITIONED,  
SOFTER, LEATHER TOP

ARTICLE	UPC/EAN	MODEL	LEATHER TOP	METAL STRUCTURE	WEIGHT	PRICE (€)
B396HILA07202	190445008706		Black		860g	160
B396HILA07203	190445008690	<b>Flyer Carved</b>	Honey	Black Steel Rail	860g	160
B396HILA07205	190445020258		Antique Brown		860g	160
B396HPLA07210	831273005917	<b>Flyer Softened</b>	Dark Tan	Black Steel	860g	160



**60°**  
RIDING POSITION

**B67**

L260 x W205 x H73 mm



**B67 Short**

L240 x W205 x H85 mm



**B67 SHORT DETAILS**

WIDER REAR PROFILE FOR GREATER STABILITY AND UPRIGHT COMFORT



ARTICLE	UPC/EAN	MODEL	LEATHER TOP	METAL STRUCTURE	WEIGHT	PRICE (€)
B427HSOA07202	831273005061	<b>B67</b>	Black	Black and Chrome Steel	850g	160
B427HSOA07203	831273005108		Honey		850g	160
B427HSOA07205	831273005085		Antique Brown		850g	160
B427DSOA07202	831273005078	<b>B67 Short</b>	Black	Black and Chrome Steel	810g	160
B427DSOA07203	831273005115		Honey		810g	160
B427DSOA07205	831273005092		Antique Brown		810g	160



**60°**  
RIDING POSITION

**B66**

L260 x W205 x H101 mm



**B66 Short**

L240 x W205 x H102 mm



**B66 DETAILS**

DOUBLE SPRUNG FRAME FOR IMPROVED  
COMFORT AND SHOCK ABSORPTION



ARTICLE	UPC/EAN	MODEL	LEATHER TOP	METAL STRUCTURE	WEIGHT	PRICE (€)
B281HSOA07202	831273005009	<b>B66</b>	Black	Black and Chrome Steel with Clamp	1050g	180
B281HSOA07203	831273005047		Honey		1050g	180
B281HSOA07205	831273005023		Antique Brown		1050g	180
B281DSOA07202	831273005016	<b>B66 Short</b>	Black	Black and Chrome Steel with Clamp	1020g	180
B281DSOA07203	831273005054		Honey		1020g	180
B281DSOA07205	831273005030		Antique Brown		1020g	180



**90°**  
RIDING POSITION

**B33**  
L318 x W235 x H110 mm



**B33 DETAILS**



TRIPLE COIL  
SUSPENDED FRAME

ARTICLE	UPC/EAN	MODEL	LEATHER TOP	METAL STRUCTURE	WEIGHT	PRICE (€)
B256S00A07202	831273005146	<b>B33</b>	Black	Chrome Steel Rail with Clamp	1600g	230
B256S00A07203	831273005153		Honey		1600g	230





**90°**  
RIDING POSITION

**NEW**

**B68**  
L260 x W205 x H52 mm



#### B68 DETAILS

ITS UN-SPRUNG METAL STRUCTURE,  
COMBINED WITH A STANDARD RAIL (7X7),  
ALLOWS THE RIDER TO MOUNT THIS SADDLE  
ON ALL MICRO-ADJUSTMENT SEATPOSTS  
AVAILABLE ON THE MARKET



ARTICLE	UPC/EAN	NEW	MODEL	LEATHER TOP	METAL STRUCTURE	WEIGHT	PRICE (€)
B282HSOA07202	190445015780	<b>NEW</b>		Black		540g	160
B282HSOA07205	190445020784	<b>NEW</b>	<b>B68</b>	Honey	Un-Sprung Metal Structure, Standard Rail (7x7)	540g	160
B282HSOA07203	831273005825	<b>NEW</b>		Antique Brown		540g	160



**90°**  
RIDING POSITION

**NEW**

**B72**  
L260 x W205 x H56 mm



**B72 DETAILS**



FEATURING A DOUBLE-COIL SPRUNG RAIL, THE B72 HAS BEEN DESIGNED FOR AN UPRIGHT RIDING POSITION, BEING THE BEST CHOICE BOTH FOR ROAD TOURER AND FIRST MTB RIDERS IN THE NEXT DECADES

ARTICLE	UPC/EAN	NEW	MODEL	LEATHER TOP	METAL STRUCTURE	WEIGHT	PRICE (€)
B391000A07202	831273005498	<b>NEW</b>	<b>B72</b>	Black	Double-Coil Sprung Rail	720g	180
B391000A07205	831273005481	<b>NEW</b>		Antique Brown		720g	180

# BAR TAPE & GRIPS

## FIT FOR LEATHER SADDLES

For our Bar Tape we use leather and microfibre giving riders the same comfort, reliability, and durability as our leather saddles, with resistance against abrasion and the wildest weather. Naturally comfortable, our grips are carefully crafted with vegetable tanned leather, and are the perfect complement to our Leather saddles and Bike Bags.

Für unsere Lenkerbänder verarbeiten wir Leder und Mikrofaser, um Fahrern und Fahrerinnen den gleichen Komfort, die gleiche Zuverlässigkeit und Langlebigkeit wie bei unseren Ledersätteln zu bieten, mit einer hohen Widerstandsfähigkeit gegen Abrieb und das widrigste Wetter. Für den Komfort werden unsere Griffe in Handarbeit aus natürlich gegerbtem Leder hergestellt und sind die perfekte Ergänzung zu unseren Ledersätteln und Fahrradtaschen.

### Slender Leather Grips

130/130, 130/100 or 100/100 mm



NATURAL MATERIAL



COMFORTABLE TO THE TOUCH



MADE TO LAST



130/130 mm



130/100 mm

100/100 mm

ARTICLE	UPC/EAN	MODEL	COLOR	DESCRIPTION	PRICE (€)
BLG4LLOA17202	8021890580757		Black		90
BLG4LLOA17203	8021890580764		Honey	130/130 mm	90
BLG4LLOA17205	8021890580771		Antique Brown	Vegetable Tanned Leather	90
BLG4LLOA17210	8021890580788	<b>Slender Leather Grips</b>	Dark Tan		90
BLG4LSOA17202	8021890580795		Black	130/100 mm	90
BLG4LSOA17203	8021890580801		Honey	Vegetable Tanned Leather	90
BLG4SSOA17202	8021890580870		Black	100/100 mm	90
BLG4SSOA17203	8021890580887		Honey	Vegetable Tanned Leather	90

**Leather Bar Tape**

Perforated Leather Tape



NATURAL MATERIAL



NATURALLY BREATHABLE



MADE TO LAST



**Microfiber Bar Tape**

3mm Comfort Padding



LIGHTWEIGHT



FOR GRIP AND CONTROL



MADE TO LAST



ARTICLE	UPC/EAN	MODEL	COLOR	DESCRIPTION	PRICE (€)
BT02000A17202	8021890581013	<b>Leather Bar Tape</b>	Black	Perforated Leather Tape	70
BT02000A17203	8021890581020		Honey		70
BT02000A17205	8021890581037		Antique Brown		70
BT03000A15202	8021890569820	<b>Microfiber Bar Tape</b>	Black	3mm Comfort Padding	35
BT03000A15203	8021890569837		Honey		35
BT03000A15205	8021890569844		Antique Brown		35

# BIKE BAGS

From touring to commuting, for journeys that are short or without a definite end, when a cyclist sets out, there are three things they must trust: themselves, their bike and their accessories. And when it comes to accessories, we put our Bike Bags second only to our Saddles in their importance to being able to ride with complete freedom and enjoy the road or trail. In fact we've put over a century of effort and ingenuity into developing bike bags that are long-lasting and with a unique style that comes also from high quality materials and premium details.

Egal, ob für Touren oder zum Pendeln, für kurze Strecken oder ohne festes Ziel - wenn ein Radfahrer sich auf den Weg macht, muss er sich auf drei Dinge verlassen können: auf sich selbst, sein Fahrrad und seine Ausrüstung. Und bei der Frage nach der richtigen Ausrüstung spielen unsere Fahrradtaschen nach unseren Sätteln die zweitwichtigste Rolle, wenn es darum geht, vollkommen frei und unbeschwert auf der Straße oder dem Trail unterwegs zu sein. Tatsächlich haben wir über ein Jahrhundert an Aufwand und Einfallsreichtum in die Entwicklung von Fahrradtaschen mit einer langen Lebensdauer und einem einzigartigen Stil gesteckt, was nicht zuletzt an den hochwertigen Materialien und erstklassigen Details liegt.

## Challenge Saddle Bag 1,2L

L260 x W65 x H110 mm



EXCEPTIONAL  
CRAFTSMANSHIP



UNIQUE PREMIUM  
DETAILS



GREATER STABILITY



ARTICLE	UPC/EAN	MODEL	COLOR	DESCRIPTION	PRICE (€)
B743700A17202	8021890581396		Black		115
B743700A17203	8021890581402	<b>Challenge Saddle Bag 1,2L</b>	Honey	Vegetable	115
B743700A17205	8021890581419		Antique Brown	Tanned Leather	115
B743700A17210	8021890581426		Dark Tan		115

# BICYCLE ACCESSORIES

The difference is in the details, and bicyclists are blessed to enjoy the Brooks design ethic applied to items that, though small, nonetheless contribute greatly to the enjoyment of the ride – while tying the machine together seamlessly in a passionate statement of visual perfection.

Es sind die Details, die den Unterschied ausmachen und so ist es für jeden Fahrradfahrer ein Glücksfall, dass die Designphilosophie von Brooks auch bei kleinen Dingen angewandt wird. Diese tragen zwar nicht immer unmittelbar zu einem gesteigerten Fahrvergnügen bei, sorgen aber dafür, dass das Fahrrad optisch perfekt in Szene gesetzt wird.

## Femto

Front & Rear Lights



## MT21

Multi-Tool



## Trousers Straps



## Sandwich Seat Adapter

**NEW**



## Leather Hub Shiner

**NEW**



ARTICLE	UPC/EAN	NEW	MODEL	COLOR	DESCRIPTION	PRICE (€)
BLLF000A12001	8021890580955		<b>Femto Front Light</b>	Copper	Front Light Copper	25
BLLR000A12001	8021890580962		<b>Femto Rear Light</b>	Copper	Rear Light Copper	25
BMT2100A17202	8021890570901		<b>Multitool MT21</b>	Black	Multi-Tool & Leather Sleeve	68
BTR1000A17202	8021890570918			Black		30
BTR1000A17203	8021890570925		<b>Trousers Straps</b>	Honey	Leather Strap	30
BTR1000A17205	8021890570932			A. Brown		30
BSSA000A0A008	8021890595126	<b>NEW</b>	<b>Sandwich Seat Adapter</b>	-	CNC alluminium worked- Hard anodized finish	45
BHS0001A07202	8021890592538	<b>NEW</b>		Black		22
BHS0001A07203	8021890592545	<b>NEW</b>	<b>Leather Hub Shiner</b>	Honey	Scrab of Leather bike bag and slender, vegetable tanned leather + metal keychain	22
BHS0001A07205	8021890592552	<b>NEW</b>		A. Brown		22

# CARE & MAINTENANCE

Whatever the material, Brooks products will age beautifully and provide the user with years of uninterrupted use. However, as such, they do require a small amount of common sense looking-after. Our selection of care products are designed to keep your Brooks saddle or bag looking great and functioning at their best.

Unabhängig vom Material werden Brooks-Produkte wunderbar altern und ihren Besitzern über viele Jahre hinweg einen ununterbrochenen Gebrauch ermöglichen. Und dennoch benötigen sie ein wenig Pflege und Aufmerksamkeit. Unsere Auswahl an Pflegeprodukten ist darauf ausgelegt, dass Ihr Brooks-Sattel oder Ihre Tasche immer gut aussieht und optimal funktioniert.



Leather Saddle  
Care Kit Dispenser  
(14 pcs)

ARTICLE	UPC/EAN	MODEL	DESCRIPTION	PRICE (€)
AMA0100A00	190445017241	Leather Saddle Care Kit Dispenser	Each box: 1 Cloth, 1 Proofide 30ml, 1 Spanner	18,00 each



**Leather Saddle  
Care Kit**



**Bike Bag  
Repair kit**



**Single  
Rain Cover**



**Proofide Single**  
30ml jar - 50ml jar

ARTICLE	UPC/EAN	MODEL	DESCRIPTION	PRICE (€)
AMA0100000	8021890542724	<b>Leather Saddle Care Kit</b>	1 Cloth, 1 Proofide 30ml, 1 Spanner	18,00
AMA0500A00	8021890569783	<b>Bike Bag Repair Kit</b>	Water Based Glue 20ml / PU Glue 15ml / Zip Wax 20ml / 2 Adhesive Patches / 3 Small Spatulas	50,00
BMK0047A00000	8021890570987	<b>Dispenser for Rain Covers S/M/L</b>	Containing 10 Medium Saddle Covers	-
BMK0048A00000	8021890570994	<b>Dispenser for Rain Covers XL</b>	Containing 10 Large Saddle Covers	-
BRCM000A18102	8021890571014	<b>Single Rain Covers S/M/L (Black)</b>	S/M/L size	15,00
BRCL000A18102	8021890571007	<b>Single Rain Covers XL (Black)</b>	Only for B73 - B190 - B135 - B33	15,00
AMA0400A1S	8021890570970	<b>Proofide Single</b>	Wax 30ml jar	14,00
AMA0400A1L	190445017289		Wax 50ml jar	18,00



# MATCHING OPPORTUNITIES

FOR LEATHER RANGE

Black



Honey



Antique  
Brown



Dark Tan



## B17\*

L275 x W175 x H65 mm/520g

## B17 Softened

L275 x W175 x H65 mm/530g

\*matching option available also  
for the other saddles models

## Slender Leather Grips

130/130, 130/100 or 100/100 mm

## Leather Bar Tape

Perforated Leather Tape



**Microfiber Bar Tape**  
3 mm Comfort Padding

**Trousers Strap**

**Challenge Saddle Bag 1,2L**  
L210 x W70 x H110 mm



**Scape  
& Bike  
bags**

# SCAPE BAGS

Attachment: KLICKFix® aluminium system.

Befestigung: KLICKFix® Aluminium-System.

Internal velcro strap for secure roll closure.

Innenliegender Klettverschluss für sicheres Schließen des Rollverschlusses.

Lightweight aluminium hook.

Leichter Aluminiumhaken.

Hypalon velcro strap to roll up the webbing end.

Hypalon-Klettband zum Aufrollen des Gurtbandendes.

Nylon webbing, strong and durable.

Nylon-Gurtband, stabil und langlebig.

Lateral daisy chain for modular set up and reflective details.

Seitliche Daisychain für modularen Aufbau sowie reflektierende Details.

Waterproof material > 50.000 water column PVC and PFC free.

Wasserdichtes Material > 50.000er Wassersäule PVC- und PFC-frei.

Front pocket flap for extra protection with one-finger zipper puller for easy access on the go.

Fronttaschenklappe für zusätzlichen Schutz mit Ein-Finger-Reißverschluss-Puller für einfachen Zugriff unterwegs.

Reflective Logo.

Reflektierendes Logo.



## Everything the adventurous cyclist might need

Whether you're hooking up a bag for a quick trip, or need to add capacity for a longer adventure and more challenging terrain, the Brooks England Scape Travel Bag range offers cyclists the versatility they need so they can focus on the journeys that lie ahead of them. For gravel, trail or the freedom and escape of bikepacking, each element in this adaptive, modular system is made to Brooks England exceptional standard of craft and care and use materials that offer the highest degrees of waterproofing and durability.

Innovative fixtures also mean bags can take multiple positions on the bike, and be easily combined for increased capacity at a moment's notice.

## Alles, was der abenteuerlustige Radfahrer brauchen könnte

Ganz gleich, ob Sie eine Tasche für einen schnellen Ausflug benötigen oder ob Sie die Transportkapazitäten für ein längeres Abenteuer und anspruchsvolleres Terrain erweitern müssen – die Brooks England Scape Travel Bag Serie bietet Radfahrern die Vielseitigkeit, die sie brauchen, um sich auf die vor ihnen liegenden Reisen zu konzentrieren. Jedes Element dieses anpassungsfähigen, modularen Systems wird nach den außergewöhnlichen Standards von Brooks England gefertigt und basiert auf Materialien, die ein Höchstmaß an Wasserdichtigkeit und Haltbarkeit bieten. Dank innovativer Vorrichtungen können die Taschen an verschiedenen Stellen des Fahrrads angebracht und leicht kombiniert werden, um das Fassungsvermögen im Handumdrehen zu erhöhen.

# Range Overview

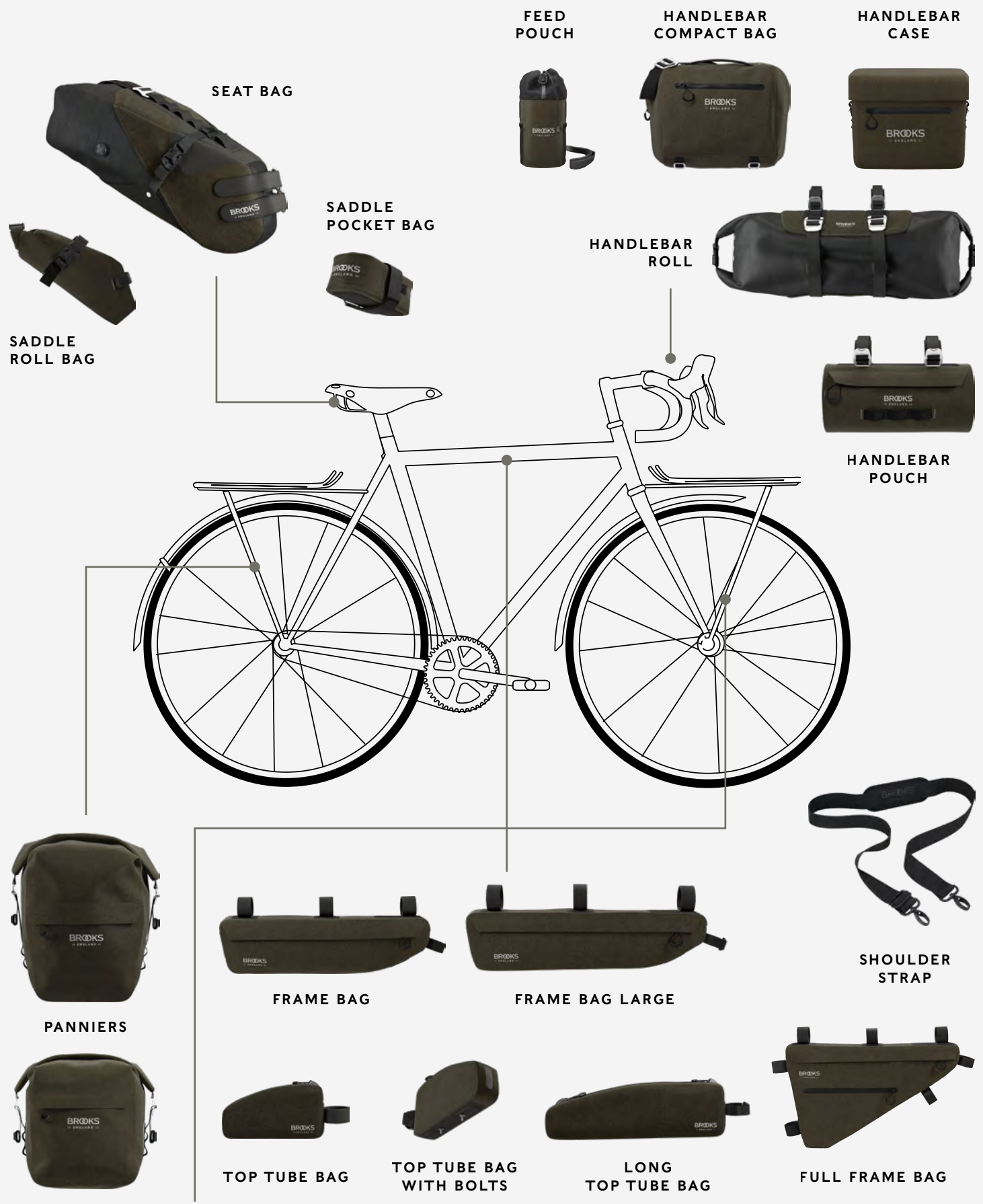

# Key Features

## PREMIUM HARDWARE



ALUMINIUM  
LIGHTWEIGHT  
RELIABLE

## RELIABLE SOFT DETAILS



PREMIUM HYPALON  
STRAPS WATERPROOF &  
WELDED FINISHING  
FLEX RESISTANT

## RELIABLE ATTACHMENTS



ALUMINIUM KLICKFIX SYSTEM  
QUICK RELEASE  
ADAPTABLE  
LIGHTWEIGHT

## WIDE VELCRO STRAPS



DETACHABLE  
VERSATILE  
REFINED (VELCRO  
BONDED WITH HYPALON)

## CLEVER SOLUTIONS



STRAP FIXING  
MULTIPLE ATTACHMENT  
OPTIONS

## DAISY CHAINS



MULTIPLE LOOPS  
FUNCTIONAL  
VERSATILE

## PROVEN ZIP OPENINGS

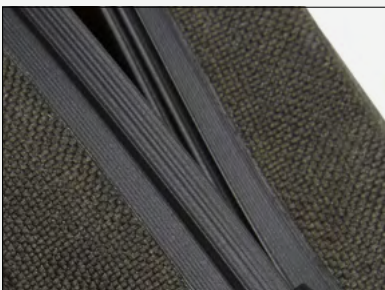

WATER-REPELLENT  
EASY TO CLEAN  
ONE-HAND OPENING

## COMPARTMENTS

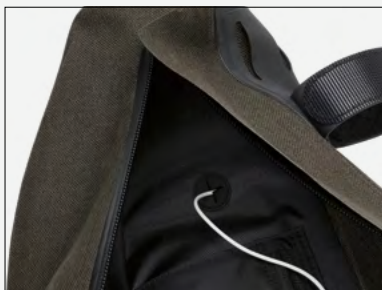

SPACE OPTIMIZATION  
EASY ACCESS

## REFLECTIVE DETAILS



CLEVER USE OF REFLECTIVE  
VISIBLE LOGO  
(EMBOSSED PRINT)





## HANDLEBAR BAGS

# Scape Handlebar Case

A classic bike handlebar bag for every cycling journey

The Scape Handlebar Case is an essential piece of cycling luggage for every long journey. Fully welded from waterproof materials, this bike adventure bag helps riders stay organized on the road thanks to a thoughtful internal layout featuring two zippered pockets and mesh sleeves. Practical and easy to open via the magnetic closure system, the Scape Handlebar Case allows access any time without having to stop and unpack, making this bag the perfect place to store your map, phone, wallet and snacks whilst riding. An external front pocket provides space for small items and documents. Off the bike, the detachable shoulder strap converts the Scape Handlebar Case into a worry-free carryall. When back on the bike, this handy bike bag attaches simply via the Klick Fix® attachment system.

Auf einer langen Reise ist die Scape Lenkertasche ein unentbehrliches Gepäckstück für Ihr Fahrrad. Gefertigt aus vollständig verschweißten, wasserdichten Materialien, hilft diese Fahrrad-Abenteuertasche Fahrern, unterwegs organisiert zu bleiben, dank einer durchdachten Innenaufteilung mit zwei Reißverschlussaschen und Netzfächern. Praktisch und einfach über das Magnetverschlussystem zu öffnen, ermöglicht die Scape Lenkertasche jederzeit Zugriff, ohne dass Sie dafür anhalten und die Tasche abnehmen müssen. So ist diese Tasche der perfekte Ort, um eine Landkarte, Telefon, Geldbörse und Snacks während der Fahrt zu verstauen. Eine externe Fronttasche bietet Platz für kleine Gegenstände und Dokumente. Abseits des Fahrrads verwandelt der abnehmbare Schultergurt die Scape Lenkertasche in eine praktische Umhängetasche. Zurück auf dem Rad lässt sich die handliche Fahrradtasche einfach über das Klick Fix®-Befestigungssystem anbringen.

### Scape Handlebar Case 8L

W260 x H225 x D170 mm

Weight: 650g



WATERPROOF



LASTING PERFORMANCE



PRACTICAL FUNCTIONALITY



ADAPTABLE & VERSATILE



### DETAILS



ARTICLE	UPC/EAN	MODEL	COLOR	DESCRIPTION	PRICE (€)
BHB05PLA00401	8021890566775	Handlebar Case 8L	Mud Green	Polyester 600D Two Tone with Hypalon details	140

# Scape Feed Pouch

## A small accessory pouch for bikepacking and cycling adventures

The Scape Feed Pouch is an on-the-go aid station for endurance riding. It offers ample food storage with fumble-free, one-handed access via an innovative drawcord system. Easily fit a one litre bottle, camera lens or more. The Scape Feed Pouch connects to either side of any bike cockpit via twin Velcro straps and a single synch strap for added stability. The convenient positioning makes for quick storage when tucking away gloves, sunglasses or any small, frequently used item on the go. The additional outside stretch mesh pocket leaves space for wrappers, sunscreen, granola bars and more while the mesh drain hole helps keep internal contents dry.

Die Scape Feed Pouch ist ein praktischer Proviantbeutel für Ausdauerfahrten. Sie bietet reichlich Stauraum für Verpflegung mit einem einhändig zu bedienenden, innovativen Kordelzugsystem. Sie können darin problemlos eine Ein-Liter-Flasche, ein Kameraobjektiv oder ähnliches unterbringen. Die Scape Feed Pouch lässt sich mit zwei Klettverschlüssen und einem weiteren Gurt für zusätzliche Stabilität beliebig an einer der beiden Seiten des Fahrradcockpits anbringen. Diese praktische Positionierung ermöglicht ein schnelles Verstauen von Handschuhen, einer Sonnenbrille oder anderen kleinen, häufig benötigten Gegenständen für unterwegs. Die zusätzliche Außentasche aus dehnbarem Mesh bietet Platz für Verpackungsmaterial, Sonnencreme, Müsliriegel und mehr, während das Mesh-Abflussloch dazu beiträgt, den Tascheninhalt trocken zu halten.

### Scape Feed Pouch 1,2L

W100 x H160 x D100 mm

Weight 100g



WATER-RESISTANT



LASTING  
PERFORMANCE



PRACTICAL  
FUNCTIONALITY



### DETAILS



ARTICLE	UPC/EAN	MODEL	COLOR	DESCRIPTION	PRICE (€)
BHB04PLA00401	8021890566768	Feed Pouch 1,2L	Mud Green	Polyester 600D Two Tone	50
BHB04PLA00000	8021890574299		Black	with Hypalon details	50

## HANDLEBAR BAGS

# Scape Handlebar Pouch

### A Handlebar Pouch for Much-Needed Items

The Scape Handlebar Pouch is a welded, fully waterproof small handlebar bag for stowing much-needed items in safety. This handlebar bag is equally at home as a bag for long-distance touring or commuting, easily fitting to most bike handlebars and furthermore finished with easy pull zippers. Two straps with aluminium buckles make mounting easy and reliable with a head tube strap to prevent the bag from swaying. It may also be attached to other Scape Bags as an extra pocket, for example above the Scape Handlebar roll.

Die Scape Handlebar Pouch ist eine verschweißte, vollständig wasserdichte kleine Lenkertasche zum sicheren Verstauen dringend benötigter Gegenstände. Diese Lenkertasche eignet sich gleichermaßen als Tasche für Langstreckentouren oder zum Pendeln. Sie lässt sich leicht an den meisten Fahrradlenkern befestigen und ist zudem mit leichtgängigen Reißverschlüssen ausgestattet. Zwei Riemen mit Aluminiumschnallen sorgen für eine einfache und zuverlässige Befestigung, ein Steuerrohrriemen verhindert ein Schaukeln der Tasche. Sie kann auch an anderen Scape-Taschen als zusätzliche Tasche angebracht werden, zum Beispiel über der Scape-Lenkerrolle.

#### Handlebar Pouch 3L

W250 x H120 x D120 mm

Weight 140g



WATERPROOF



LASTING  
PERFORMANCE



PRACTICAL  
FUNCTIONALITY



ADAPTABLE &  
VERSATILE



#### DETAILS



ARTICLE	UPC/EAN	MODEL	COLOR	DESCRIPTION	PRICE (€)
BHB01PLA00401	190445017661	Handlebar Pouch 3L	Mud Green	Polyester 600D Two Tone with Hypalon details	70
BHB01PLA00000	8021890567239		Black		70

# Scape Handlebar Compact Bag

A Handlebar Bag for Commuting and Travelling

The Scape Handlebar Compact Bag is a removable cycling briefcase made from lightweight, waterproof materials and all-round weatherproof details with an understated modern look. This bag is equally at home as a bag for long-distance touring or commuting, featuring internal neoprene organisation with a padded, 13" laptop compartment, a zip pocket and two stretch mesh pockets. Two aluminium buckles on the bottom allow a quick and easy adjustment of the internal space of the bag. Finished with easy double pull zippers and a Klick Fix® attachment system, a shoulder strap is included for easy carriage when off the bike, used as cross body bag or shoulder bag.

Die Scape Handlebar Compact Bag ist eine abnehmbare Fahrradtasche aus leichten, wasserdichten Materialien und rundum wetterfesten Details mit einem dezent modernen Look. Diese Tasche eignet sich gleichermaßen als Tasche für Langstreckentouren oder zum Pendeln. Sie verfügt über eine interne Einteilung aus Neopren mit einem gepolsterten 13"-Laptopfach, einer Reißverschlusstasche und zwei Stretch-Netztaschen. Zwei Aluminiumschnallen an der Unterseite ermöglichen eine schnelle und einfache Anpassung des Innenraums der Tasche. Die Tasche ist mit einfach zu bedienenden Doppelzug-Reißverschlüssen und einem Klick Fix®-Befestigungssystem ausgestattet. Ein mitgelieferter Schultergurt erleichtert den Transport abseits des Fahrrads und ermöglicht die Verwendung als Crossbody-Bag oder Schultertasche.

## Handlebar Compact Bag 10L

W340 x H250 x D140 mm

Weight 475g



WATER-RESISTANT



LASTING PERFORMANCE



PRACTICAL FUNCTIONALITY



ADAPTABLE & VERSATILE



Non utilizzare con manubri in carbonio.

## DETAILS



ARTICLE	UPC/EAN	MODEL	COLOR	DESCRIPTION	PRICE (€)
BHB02PLA00401	190445017753	Handlebar Compact Bag 10L	Mud Green	Polyester 600D Two Tone with Hypalon details	120

## HANDLEBAR BAGS

# Scape Handlebar Roll

A Handlebar Roll, Built for Adventure

Built for adventure, the Scape Handlebar Roll is a bikepacking bag made from two separate elements: a holster and a 100% waterproof (IPX4 certified) removable drybag featuring two internal compartments made from lightweight, waterproof materials and all-round weatherproof details. Specially designed for long-distance touring and bikepacking races and easily attaching to both drop (road and gravel type) and straight (MTB) handlebars, the holster attaches via two straps with aluminium buckles to make mounting quick and reliable, with EVA spacers to allow easy passage of cables and a fuller grip. A double daisy chain runs through the holster to hold bulkier items.

Die Scape Handlebar Roll ist eine Bikepacking-Tasche, die aus zwei separaten Elementen besteht: einem Holster und einem 100% wasserdichten, herausnehmbaren Drybag mit zwei Innenfächern aus leichten, wasserdichten Materialien und rundum wetterfesten Details. Das Holster wurde speziell für Langstreckentouren und Bikepacking-Rennen entwickelt und lässt sich sowohl an Drop- (Straßen- und Gravel) als auch an geraden (MTB) Lenkern befestigen. Die Befestigung erfolgt über zwei Riemen mit Aluminiumschnallen, die eine schnelle und zuverlässige Montage ermöglichen, sowie über EVA-Abstandshalter, die eine einfache Kabeldurchführung und einen besseren Halt gewährleisten. Im Holster verläuft eine doppelte Daisy Chain, um sperrigere Gegenstände zu halten.

### Handlebar Roll 9-11L

W350-400 x H160 x D160 mm

Weight 670g



WATERPROOF (IPX4)



LASTING  
PERFORMANCE



PRACTICAL  
FUNCTIONALITY



### DETAILS



ARTICLE	UPC/EAN	MODEL	COLOR	DESCRIPTION	PRICE (€)
BHB03PLA00401	190445017678	Handlebar Roll 9-11L	Mud Green	Polyester 600D Two Tone	140
BHB03PLA00000	802189057428		Black	with Hypalon details	140

# Scape Seat Bag

## A Seat Bag Made for Gravel and Adventure Cycling

Made for gravel and adventure cycling, the Scape Seat Bag is a bikepacking bag made from two separate elements: a holster and a 100% waterproof (IPX4 certified) removable drybag. The holster is built from rugged materials to last, the holster bottom designed to act as a mudguard and protect the internal bag from any rear wheel contact. The dry bag easily compresses thanks to its air valve release mechanism to minimise bulk, and can be rolled smaller when less carrying space is needed. The daisy chain allows attachment of modular bags, and a loop is included to attach a rear light.

Made from waterproof material to be prepared for any ride, regardless of conditions.

Die Scape Seat Bag ist eine Fahrradtasche, die aus zwei separaten Elementen besteht: einem Holster und einem 100% wasserdichten (IPX4-zertifizierten) herausnehmbaren Drybag. Das Holster ist aus robusten, strapazierfähigen Materialien gefertigt. Der Boden des Holsters dient gleichzeitig als Schutzblech und schützt die Innentasche vor jeglichem Kontakt mit dem Hinterrad. Der Trockensack lässt sich dank seines Entlüftungsmechanismus leicht komprimieren, um das Volumen zu minimieren, und kann zusammengerollt werden, wenn weniger Platz zum Tragen benötigt wird. Die Daisy Chain ermöglicht das Anbringen von modularen Taschen und an der zusätzlichen Schlaufe kann ein Rücklicht befestigt werden. Hergestellt aus wasserdichtem Material, um für jede Fahrt vorbereitet zu sein, unabhängig von den Bedingungen.

### Seat Bag 8-10L

W400-600 x H180 x D140 mm

Weight 500g



WATERPROOF (IPX4)



LASTING  
PERFORMANCE



PRACTICAL  
FUNCTIONALITY



### DETAILS



ARTICLE	UPC/EAN	MODEL	COLOR	DESCRIPTION	PRICE (€)
BSB03PLA00401	190445017739	Seat Bag 8-10L	Mud Green	Polyester 600D Two Tone	140
BSB03PLA00000	8021890574305		Black	with Hypalon details	140

## SADDLE BAGS

# Scape Saddle Pocket Bag

Modular Saddle Bag That Attaches in Multiple Ways

The Scape Saddle Pocket Bag is a small, practical 100% waterproof bag for bikepacking or gravel cycling that attaches in multiple ways. Made from welded construction, waterproof materials and details to protect the bag from tears and abrasions, it additionally uses internal padded foam on both sides to protect your belongings. A coated zipper with auto lock puller runs around the perimeter of the bag for maximum opening and hypalon patches on both sides guarantee protection. Used as a classic saddle bag or as a versatile pocket bag to attached in multiple ways to the other Scape bags for convenient additional storage space.

Die Scape Saddle Pocket Bag ist eine kleine, praktische, 100% wasserdichte Tasche für Bikepacking oder Gravel Radsport, die sich auf verschiedene Arten befestigen lässt. Sie besteht aus einer geschweißten Konstruktion, wasserdichten Materialien und Details, die die Tasche vor Rissen und Scheuerstellen schützen. Zusätzlich verfügt sie über einen innenliegenden, polsternden Schaumstoff auf beiden Seiten, um Ihre Habseligkeiten zu schützen. Ein umlaufender, beschichteter Reißverschluss mit Auto-Lock-Puller sorgt für maximale Zugänglichkeit der Tasche und Hypalon-Patches auf beiden Seiten garantieren Schutz. Sie kann als klassische Satteltasche oder als vielseitige Taschentasche verwendet werden, die auf verschiedene Weise an den anderen Scape-Taschen befestigt werden kann, um bequem zusätzlichen Stauraum zu schaffen.

### Saddle Pocket Bag 0,7L

W150 x H55 x D80 mm

Weight 70g



WATERPROOF



LASTING  
PERFORMANCE



PRACTICAL  
FUNCTIONALITY



ADAPTABLE &  
VERSATILE



### DETAILS



ARTICLE	UPC/EAN	MODEL	COLOR	DESCRIPTION	PRICE (€)
BSB01PLA00401	190445017715	Saddle Pocket Bag 0,7L	Mud Green	Polyester 600D Two Tone with Hypalon details	50
BSB01PLA00000	8021890567260		Black		50

# Scape Saddle Roll Bag

A Saddle Bag Made for Medium Loads

Made for bikepacking, gravel and adventure cycling, the Scape Saddle Roll Bag is a 100% waterproof (IPX4 certified), entirely welded bag designed to fit perfectly on almost any bike. Built to last from rugged materials, and designed to maximise its 1l capacity. The roll closure allows easy access as well as space optimisation, rolling smaller when less carrying space is needed. Made from waterproof materials to be prepared for the ride, regardless of conditions.

Die Scape Saddle Roll Bag ist eine 100% wasserdichte, komplett verschweißte Tasche, die perfekt an fast jedes Fahrrad passt. Sie ist aus robusten Materialien gefertigt und so konzipiert, dass das Fassungsvermögen von 1l optimal genutzt werden kann. Der Rollverschluss ermöglicht einen einfachen Zugang sowie eine Platzoptimierung, indem er kleiner zusammengerollt werden kann, wenn weniger Platz zum Tragen benötigt wird. Hergestellt aus wasserdichten Materialien, um für jede Tour gerüstet zu sein, unabhängig von den Bedingungen.

## Saddle Roll Bag 1L

W320 x H100 x D100 mm

Weight 75g



WATERPROOF (IPX4)



LASTING  
PERFORMANCE



PRACTICAL  
FUNCTIONALITY



## DETAILS



ARTICLE	UPC/EAN	MODEL	COLOR	DESCRIPTION	PRICE (€)
BSB02PLA00401	190445017722	<b>Saddle Roll Bag 1L</b>	Mud Green	Polyester 600D Two Tone with Hypalon details	50



## PANNIERS

# Scape Small Pannier

A perfect pannier for the front or rear rack

The Scape Small Pannier is a 100% welded waterproof (IPX4 certified) bag with a roll top closure and weatherproof details, perfectly at home on the front or rear rack. Made to last, this modern bag for cycle touring is constructed from hard-wearing details and specially selected components like the external pocket with protective flap that increases the capacity of the bag while helping to organise its contents. The bag also offers special modular functionality to attach other bags from the Scape range thanks to the lateral daisy chain. Provided with the aluminium Klick Fix® attachment system for easy fastening to most rack systems.

Die Scape Small Pannier ist eine 100% wasserdichte Tasche mit Rollverschluss und wetterfesten Details, die perfekt auf dem Vorder- oder Hinterradgedäckträger angebracht werden kann. Diese moderne Tasche für Radtouren ist langlebig und besteht aus strapazierfähigen Details und speziell ausgewählten Komponenten wie der Außentasche mit Schutzlasche, die das Fassungsvermögen der Tasche erhöht und gleichzeitig hilft, ihren Inhalt zu organisieren. Die Tasche bietet auch eine besondere modulare Funktionalität, um andere Taschen aus der Scape-Reihe mithilfe der seitlichen Daisy Chain zu befestigen. Ausgestattet mit dem Aluminium Klick Fix®-Befestigungssystem zur einfachen Montage an den meisten Gepäckträgersystemen.

### Small Pannier 10-13L

W260 x H300-470 x D150 mm

Weight 630g



WATERPROOF (IPX4)



LASTING PERFORMANCE



PRACTICAL FUNCTIONALITY



### DETAILS



ARTICLE	UPC/EAN	MODEL	COLOR	DESCRIPTION	PRICE (€)
BPA01PLA0S401	190445017708	Small Pannier 10-13L	Mud Green	Polyester 600D Two Tone with Hypalon details	120
BPA01PLA0S000	8021890567253		Black		120

# Scape Large Pannier

A modern and functional rear pannier

The Scape Large Pannier is a 100% waterproof (IPX4 certified) bag designed for the rear rack, with welded construction and weatherproof details such as a roll top closure with reliable internal velcro strap for expandable volume that keeps its contents dry. Made to last, this bag for cycle touring is constructed from hard-wearing details and specially selected components such as an external pocket with protective flap that increases bag capacity while helping to organise its contents. A special modular functionality to attach other bags from the Scape range, or a rear light, is provided by the bag's lateral daisy chain. Furthermore provided with an aluminium Klick Fix® attachment system to fit most any rear rack.

Die Scape Large Pannier ist eine 100 % wasserdichte Tasche, die für den Gepäckträger entwickelt wurde. Sie besteht aus einer geschweißten Konstruktion und wetterfesten Details wie einem Rolltop-Verschluss mit zuverlässigem internen Klettverschluss für ein erweiterbares Volumen, das den Inhalt trocken hält. Diese langlebige Radtourentasche überzeugt durch strapazierfähige Details und speziell ausgewählte Komponenten wie eine Außentasche mit Schutzklappe, die das Fassungsvermögen der Tasche erhöht und gleichzeitig hilft, den Inhalt zu organisieren. Eine besondere modulare Funktionalität zur Befestigung anderer Taschen aus der Scape-Reihe oder eines Rücklichts wird durch die seitlichen Befestigungsmöglichkeiten an der Tasche geboten. Außerdem ist die Tasche mit einem Klick Fix®-Befestigungssystem aus Aluminium ausgestattet, das an fast jeden Gepäckträger passt.

## Large Pannier 18-22L

W320 x H400-600 x D160 mm

Weight 760g



WATERPROOF (IPX4)



LASTING  
PERFORMANCE



PRACTICAL  
FUNCTIONALITY



## DETAILS



ARTICLE	UPC/EAN	MODEL	COLOR	DESCRIPTION	PRICE (€)
BPA01PLA0L401	190445017685	Large Pannier 18-22L	Mud Green	Polyester 600D Two Tone with Hypalon details	125
BPA01PLA0L000	8021890567246		Black		125

## FRAME BAGS

# Scape Full Frame

A full frame bag for adventure cycling and bikepacking

Fit for most standard-sized frames, the Scape Full Frame Bag is a 100% waterproof cycling frame bag designed for bikepacking, gravel and other all-day adventure cycling pursuits. An entirely welded construction ensures the pack is completely waterproof and holds its streamlined shape while in position on the bike, making it great for storing much-needed items via a spacious main compartment that features full-length zippers with ergonomic zipper pullers for fast and easy access. The small waterproof zippered pocket utilises an innovative KCC zipper and is perfect for organizing small items safely. A TPU cable ports and other smart touches add practicality to every off-road ride. For convenient bikepacking-ready storage, the Scape Full Frame Bag attaches securely via seven Hypalon Velcro straps.

Die Scape Full Frame Bag ist eine 100% wasserdichte Rahmentasche, welche für die meisten Standard-Rahmengrößen geeignet ist und für Bikepacking, Gravel Riding und andere ganztägige Fahrradabenteuer entwickelt wurde. Die komplett verschweißte Konstruktion sorgt dafür, dass die Tasche absolut wetterfest ist und ihre stromlinienförmige Form beibehält, wenn sie am Fahrrad angebracht ist. Im geräumigen Hauptfach mit durchgehenden Reißverschlüssen und ergonomischen Zipper-Pullern für schnellen und einfachen Zugriff lassen sich viele wichtige Dinge verstauen. Eine kleine wasserdichte Reißverschluss tasche mit innovativem KCC-Reißverschluss ist perfekt, um kleine Gegenstände sicher zu verstauen. Ein TPU-Kabelausgang und andere clevere Details sorgen für mehr Praktikabilität bei jeder Offroad-Tour. Für eine effiziente Nutzung als Bikepacking-Tasche lässt sich die Scape Full Frame Bag mit sieben Hypalon-Klettbindern sicher befestigen.

### Scape Full Frame Bag 5,5L

W480 x H290 x D60 mm

Weight: 390g



WATERPROOF



LASTING  
PERFORMANCE



PRACTICAL  
FUNCTIONALITY



## DETAILS



ARTICLE	UPC/EAN	MODEL	COLOR	DESCRIPTION	PRICE (€)
BFB02PLA00401	8021890566751	Full Frame 5,5L	Mud Green	Polyester 600D Two Tone	120
BFB02PLA00000	8021890574275		Black	with Hypalon details	120

# Scape Frame Bag

A Frame Bag with an Easy Access On-The-Go

Able to fit most standard-sized frames, the Scape Frame Bag is a 100% waterproof, cycling half frame bag suitable for bikepacking, gravel and other all-day adventure cycling pursuits. An entirely welded construction ensures the pack is completely waterproof and holds its streamlined shape while in position on the bike, and is great for storing longer items such as a pump or tent poles via its two full length zips with an ergonomic zipper puller for fast and easy access. The main compartment comes equipped with internal organisation and a cable hole, while the corresponding waterproof zip on the opposite side, utilising the innovative KCC zip, is designed for small items. Attaches easily via Hypalon velcro straps.

Die Scape Rahmentasche passt an die meisten Standard-Rahmen und ist eine 100% wasserdichte Fahrrad-Halbrahmentasche, die sich für Bikepacking, Gravel Rides und andere ganztägige Fahrradabenteuer eignet. Die komplett verschweißte Konstruktion sorgt dafür, dass die Tasche komplett wasserdicht ist und ihre stromlinienförmige Form beibehält, wenn sie am Fahrrad angebracht ist. Zudem eignet sie sich dank der zwei durchgehenden Reißverschlüsse mit ergonomischen Reißverschluss-Pullern für einen schnellen und einfachen Zugriff zum Verstauen längerer Gegenstände wie einer Pumpe oder Zeltstangen. Das Hauptfach ist mit internen Einteilungen und einem Kabelausgang ausgestattet, während der wasserdichte Reißverschluss auf der gegenüberliegenden Seite, mit dem innovativen KCC-Reißverschluss, für kleinere Gegenstände gedacht ist. Die Befestigung erfolgt einfach über Hypalon-Klettbander.

## Frame Bag 3L

W460 x H120 x D60 mm

Weight 215g



WATERPROOF



LASTING PERFORMANCE



PRACTICAL FUNCTIONALITY



## DETAILS



ARTICLE	UPC/EAN	MODEL	COLOR	DESCRIPTION	PRICE (€)
BFB01PLA00401	190445017654	Frame Bag 3L	Mud Green	Polyester 600D Two Tone	95
BFB01PLA00000	8021890567222		Black	with Hypalon details	95

## FRAME BAGS

# Scape Frame Bag Large

A spacious frame bag for bike adventures of all sizes

With more room for bigger adventures, the Scape Large Frame Bag is a waterproof bikepacking bag designed with multiple pockets to allow riders to stay organized while exploring our world. Bring what you need for extended escapes in the Scape Large Frame Bag. Designed to provide space for more adventure essentials, our versatile bikepacking frame bag features welded construction for wet-weather protection. Dual side pockets, one with a full-length zipper to access the main compartment and the other with a smaller KCC waterproof zipper, combine with an internal organizer pocket for easy storage on the go. Attached to the frame via secure Hypalon Velcro straps, the Scape Large Frame Bag fits most standard bike styles and is roomy enough for wherever you choose to roll.

Mit mehr Platz für größere Abenteuer ist die Scape Large Frame Bag eine wetterfeste Bikepacking-Tasche, ausgestattet mit zahlreichen Fächern, die es den Fahrern ermöglichen, auf ihren Entdeckungsreisen durch die Welt, stets organisiert zu bleiben. Mit der Scape Large Frame Bag haben Sie alles dabei, was Sie für ausgedehnte Ausflüge brauchen. Unsere vielseitige Bikepacking-Rahmentasche mit ihrer verschweißten Konstruktion zum Schutz vor Nässe bietet Platz für eine Vielzahl von Utensilien auf Ihren Abenteuern. Zwei seitliche Fächer, eines mit durchgehendem Reißverschluss für einen bequemen Zugang zum Hauptfach, das andere mit einem kleineren, wasserdichten KCC-Reißverschluss, sorgen zusammen mit einem internen Organizerfach für eine einfache und übersichtliche Aufbewahrung unterwegs. Die Scape Large Frame Bag wird mit zuverlässigen Hypalon-Klettverschlüssen am Rahmen befestigt. Sie passt an die meisten gängigen Fahrradmodelle und ist geräumig genug Sie auf allen Reisen zu begleiten, egal wo.

### Frame Bag Large 3,5L

W500 x H120 x D46 mm

Weight 200g



WATERPROOF



LASTING  
PERFORMANCE



PRACTICAL  
FUNCTIONALITY



## DETAILS



ARTICLE	UPC/EAN	MODEL	COLOR	DESCRIPTION	PRICE (€)
BFB03PLA00401	8021890573902	Frame Bag Large 3,5L	Mud Green	Polyester 600D Two Tone	100
BFB03PLA00000	8021890576378		Black	with Hypalon details	100

# Scape Long Top Tube Bag

A roomy top tube bag for easy access to essentials

The Scape Long Top Tube Bag provides the perfect place to keep adventure essentials, with a dual-sided waterproof zipper and welded construction to protect your important items from inclement weather. Packing for big adventures requires practical storage solutions. Keeping important items both organized and protected from the elements, the Scape Long Top Tube bag puts more of what you need easily within reach, whatever the road. Pack snacks for gravel riding or maps for guiding bike exploration off the grid. The expanded capacity of our Long Top Tube Bag means you'll never be far from adventure essentials. The dual-sided zipper is both waterproof and easy to operate, even with one hand. Connected simply and securely via Hypalon straps, make the most of your available space with Scape.

Die Scape Long Top Tube Bag ist der perfekte Aufbewahrungsort für Ihre wichtigsten Abenteuerutensilien. Der beidseitig wasserdichte Reißverschluss und die verschweißte Konstruktion schützen Ihre wichtigen Gegenstände vor schlechtem Wetter. Das Packen für große Abenteuer erfordert vor allem praktische Aufbewahrungslösungen. In der Scape Long Top Tube Bag sind alle wichtigen Dinge gut organisiert und vor Wind und Wetter geschützt, so dass dennoch Sie immer alles in Reichweite haben, wenn Sie es brauchen. Nehmen Sie Snacks für Gravel Rides oder Karten für Erkundungstouren fernab der Zivilisation mit. Dank des größeren Fassungsvermögens unserer Long Top Tube Bag sind die wichtigsten Dinge immer griffbereit. Der doppelseitige Reißverschluss ist sowohl wasserdicht als auch leicht zu bedienen, sogar mit einer Hand. Einfach und sicher mit Hypalon-Riemen befestigt, holen Sie mit den Taschen der Scape Serie das Maximum aus dem zur Verfügung stehenden Platz heraus.

## Long Top Tube Bag 1,5L

W370 x H110 x D40 mm

Weight 150g



WATERPROOF



LASTING  
PERFORMANCE



PRACTICAL  
FUNCTIONALITY



## DETAILS



ARTICLE	UPC/EAN	MODEL	COLOR	DESCRIPTION	PRICE (€)
BTTO2PLA00401	8021890573926	Long Top Tube Bag 1,5L	Mud Green	Polyester 600D Two Tone with Hypalon details	65
BTTO2PLA00000	8021890576385		Black		65

## FRAME BAGS

# Scape Top Tube Bag

## A Convenient Accessory Bag for Oft-Needed Items

A convenient accessory bag for much-needed items, the Scape Top Tube Bag is a convenient, 100% waterproof, welded bikepacking bag for much-needed items, equipped with an innovative, fully waterproof, easy-pull coated YKK zipper to keep your bags' contents dry and safe. An entirely welded construction ensures the pack is completely waterproof and holds its streamlined shape while in position on the bike. The lateral sides and bottom are constructed internally with padded foam to protect contents and reduce clatter. Finished with smart and modern details like an exterior reflective logo and a front TPU cable hole. Attaches easily with Hypalon velcro straps.

Die Scape Oberrohr Tasche ist eine praktische, 100 % wasserdichte, verschweißte Bikepacking-Tasche für dringend benötigte Gegenstände, die mit einem innovativen, leicht zu ziehenden, beschichteten YKK-Reißverschluss ausgestattet ist, um den Inhalt der Tasche trocken und sicher zu halten. Eine komplett verschweißte Konstruktion sorgt dafür, dass die Tasche komplett wasserdicht ist und ihre stromlinienförmige Form behält, während sie auf dem Fahrrad angebracht ist. Die seitlichen Seiten und der Boden sind innen mit einer Schaumstoffpolsterung versehen, um den Inhalt zu schützen und Klappern zu reduzieren. Abgerundet wird die Tasche durch clevere und moderne Details wie ein außen angebrachtes reflektierendes Logo und ein TPU-Kabelloch an der Vorderseite. Lässt sich leicht mit Hypalon-Klettbindern befestigen.

### Top Tube Bag 0,9L

W210 x H110 x D40 mm  
Weight 100g



WATERPROOF



LASTING PERFORMANCE



PRACTICAL FUNCTIONALITY



### Top Tube Bag e with bolts 0,9L

W210 x H110 x D40 mm  
Weight 100g



## DETAILS



WITH BOLTS

ARTICLE	UPC/EAN	MODEL	COLOR	DESCRIPTION	PRICE (€)
BTTO1PLA00401	190445017746	<b>Top Tube Bag 0,9L</b>	Mud Green	Polyester 600D Two Tone with Hypalon details	55
BTTO1PLA00000	8021890567277		Black		55
BTT03PLA00401	8021890573933	<b>Top Tube Bag 0,9L with bolts</b>	Mud Green	Polyester 600D Two Tone with Hypalon details	65
BTT03PLA00000	8021890576392		Black		65

# SCAPE ACCESSORIES

**Scape Bike Bag  
Pannier Shoulder Strap**  
For Panniers and Pouch



ARTICLE	UPC/EAN	MODEL	COLOR	DESCRIPTION	PRICE (€)
ABB01PLA00000	190445017623	<b>Scape Bike Bag Pannier Shoulder Strap</b>	Black	Nylon and Hypalon	25





**Backpack**

**&**

**Shoulder**

**bags**

# PICKWICK



## **A stylish, handmade roll-top backpack, available in a variety of styles and materials.**

Forever one of our most favoured backpack designs, the Pickwick features a simple roll-top closure for expandable capacity designed to fit the way you navigate your day. Available in a variety of different materials and styles, from vegetable-tanned leather that promises to patina beautifully with use to durable cotton canvas and more.

Maximum capacity with minimum fuss—that's the Pickwick.

## **Ein stilvoller, handgefertigter Rolltop-Rucksack, erhältlich in einer Vielzahl von Stilen und Materialien.**

Der Pickwick ist einer unserer beliebtesten Rucksäcke. Er hat einen einfachen Rolltop-Verschluss und eine erweiterbare Kapazität, die sich an Ihren Tagesablauf anpasst. Er ist in einer Vielzahl von Materialien und Stilen erhältlich – von pflanzlich gegerbtem Leder, das mit der Zeit eine schöne Patina annimmt, bis hin zu strapazierfähigem Baumwoll-Canvas und mehr.

Maximale Kapazität bei minimalem Aufwand – das ist der Pickwick.

**Pickwick Cotton Canvas 12L**

L260 x W120 x H410/470 mm



EXPANDABLE  
CAPACITY



KEEPS BELONGINGS  
SAFE & SECURE



EASILY ADJUSTABLE



UNIQUE PREMIUM  
DETAILS



PADDED 13" OR 15"  
LAPTOP COMPARTMENT



**NEW COLOR**

**NEW COLOR**

**NEW COLOR**

**DETAILS**



ARTICLE	UPC/EAN	NEW	MODEL	COLOR	DESCRIPTION	PRICE (€)
BB02200A07200	190445007198		<b>Pickwick Cotton Canvas 12L</b>	Total Black	Water Resistant Cotton Canvas with Leather Details, Roll Top Closure, 13" Laptop Sleeve	220
BB02200A07266	190445007129			Grey/Honey		220
BB02200A07232	8021890581655			Sage Green/Honey		220
BB02200A07267	190445007112	<b>NEW</b>		Dark Blue/Black		220
BB02200A07249	190445007174	<b>NEW</b>		Goose Beak/Maroon		220
BB02200A07282	190445016015	<b>NEW</b>		Forest		220

## Pickwick Cotton Canvas 26L

L310 x W150 x H480/550 mm



EXPANDABLE  
CAPACITY



KEEPS BELONGINGS  
SAFE & SECURE



EASILY ADJUSTABLE



UNIQUE PREMIUM  
DETAILS



PADDED 13" OR 15"  
LAPTOP COMPARTMENT



**NEW COLOR**

**NEW COLOR**

### DETAILS



ARTICLE	UPC/EAN	NEW	MODEL	COLOR	DESCRIPTION	PRICE (€)
BB04300A07200	190445005804		<b>Pickwick Cotton Canvas 26L</b>	Total Black	Water Resistant Cotton Canvas with Leather Details, Roll Top Closure, 15" Laptop Sleeve	250
BB04300A07266	190445009765			Grey/Honey		250
BB04300A07282	190445016022			Forest		250
BB04300A07267	190445009741			Dark Blue/Black		250
BB04300A07249	190445009758	<b>NEW</b>		Goose Beak/Maroon		250
BB04300A07232	8021890581662	<b>NEW</b>		Sage Green/Honey		250

**Hoxton Basket 25L**

L380 x W260 x H260 mm



UNIQUE PREMIUM  
DETAILS



SPECIALLY SELECTED  
COMPONENTS



GREATER STABILITY



**Bricklane Roll-up Panniers 15L**

L350 x W120 x H360 mm



EXPANDABLE  
CAPACITY



UNIQUE PREMIUM  
DETAILS



GREATER STABILITY



**DETAILS**



ARTICLE	UPC/EAN	MODEL	COLOR	DESCRIPTION	PRICE (€)
BB00300A10003	8021890569790	<b>Hoxton Basket 25L</b>	Aluminium	Wire Basket with Wooden Base (included click fix mount)	190
BB00100A07266	190445008409	<b>Bricklane Roll-up Panniers 15L</b>	Grey/Honey	Water Resistant Cotton Canvas with Leather Details	200
BB00100A07232	8021890579706		Sage Green/Honey		200
BB00100A07249	8021890579713		Goosebeack/Maroon		200

# **Accessories & Spare parts**

# ACCESSORIES & SPARE PARTS

ARTICLE	MODEL	DESCRIPTION	PRICE (€)
<b>CAMBIUM ALL WEATHER</b>			
BYB0469A00000	<b>Rails</b>	C17 / C17C All Weather Bracket	15
BYB0470A00000	<b>Rails</b>	C15 / C15C All Weather Bracket	15
BYB0471A00000	<b>Rails</b>	C19 / C19C All Weather Bracket	15
BYB0472A00000	<b>Nose Pieces</b>	C15 / C17 All Weather Nose Kit Replacement	9
BYB0473A00000	<b>Nose Pieces</b>	C19 All Weather Nose Kit Replacement	9
BYB0475A00000	<b>Stud and Bolt</b>	C15 / C17 / C19 All Weather Square / B Boss + Screw	24
<b>CAMBIUM</b>			
BYB0373A00000	<b>Rails - Tubular Steel</b>	Cambium C15	33
BYB0366A00000	<b>Rails - Tubular Steel</b>	Cambium C17, C17 Carved	33
BYB0414A00000	<b>Rails - Tubular Steel</b>	Cambium C19	33
BYB0369A00000	<b>Rail Caps</b>	For all Cotton Cambium saddles	4,50
BYB0370A00000	<b>Nose Pieces</b>	Cambium C17/C17 Carved/C17 S/C17S Carved/C15/C15 Carved	17
BYB0415A00000	<b>Nose Pieces</b>	For C19 Cambium saddles	17
<b>CLAMPS (FOR LEATHER SADDLES)</b>			
BYB0101A00000	<b>Clamp 7/8" (22.2MM) for 1 Rail - Chrome</b>	For All Single Rail Models	23
BYB0105A00000	<b>Clamp 7/8" (22.2MM) for 2 Rail - Chrome</b>	For Double Rail Models (B66, B66's, B72, B73)	23
BYB0107A00000	<b>Clamp 7/8" (22.2MM) for 3 Rail - Chrome</b>	For Triple Rail Models (B33)	23
BMP0178A00000	<b>Boss Bar &amp; Nut Assy (Bolt-Zinc/Nuts-Chrome)</b>	All Clipped Saddles	6
<b>SPRINGS (LEATHER SADDLES)</b>			
BYB0224A00000	<b>Right Hand Stranded Coil - Chrome</b>	B33	13,50
BYB0350A00000	<b>Left Hand Stranded Coil - Chrome</b>	B33	13,50
BYB0227A00000	<b>Right Hand Coil - Chrome</b>	B66, B66 's', B73, B67, Champion, Champion'S	9
BYB0236A00000	<b>Left Hand Coil - Chrome</b>	B66, B66 's', B73, B67, Champion, Champion'S	9
BYB0250A00000	<b>Right Hand Coil - Black</b>	B67, B67 's', Flyer, Flyer 's', Flyer Special, Flyer Special 's', Conquest, Countess, B135, B190	9
BYB0253A00000	<b>Left Hand Coil - Black</b>	B67, B67 S , Flyer, Flyer 's', Flyer Special, Flyer Special 's', Conquest, Countess, B135, B190	9
BYB0242A00000	<b>Left Hand Coil - Chrome</b>	B135, B190	23
BMP0172A00000	<b>15/16" Bolt and Nut Assembly - Zinc</b>	B33	6
BMP0180A00000	<b>1" Bolt and Nut Assembly - Zinc</b>	B66, B66 's', B67, B67 's', Flyer, Flyer 's', Flyer Special, Flyer Special 's', B73, Conquest, Countess	6
<b>NOSE PARTS (LEATHER SADDLE)</b>			
BMP0173A00000	<b>Tension Pin Assembly 64mm with Nut - Zinc</b>	B17, B17 Narrow, Flyer, Flyer Special, Professional 's', B17 's', B66, B66 's', B73, B72, Flyer 's', Flyer 's' Special, Finesse, B67, B67 's', B68, B68 's', Swift/Swallow Chrome, Countess	10
BMP0185A00000	<b>Tension Pin assembly 60mm with Nut - Zinc</b>	Swift Titanium , B17 Titanium, Team Prof Titanium	7,50
BMP0306A00000	<b>Tension Pin 54mm - Zinc</b>	B33, B135	7,50
BYB0140A00000	<b>Tension Shackle - Chrome</b>	Team Professional, Professional 's', B17, B17 's', B17 Narrow, Flyer Special, Flyer Special 's', Swift/Swallow Chrome, B67, Conquest, Countess	7
BYB0289A00000	<b>Tension Shackle - Titanium</b>	Swift Titanium, Finesse, B17 Titanium, Team Prof	20
<b>RIVETS (LEATHER SADDLE)</b>			
BYB0421A00000	<b>Ø 8.75mm Solid Rivet can be used to replace tubrivets (3 pieces) - Nickel</b>	B66, B66 's', B67, B67 's', B73, B33, B17 Std, B17 Narrow, B72, Flyer, Flyer 's', Swallow, Aged Line	7
<b>MISCELLANEOUS</b>			
BMP0183A00000	<b>9/32" Nut - Zinc</b>	All Sprung saddles	3,50
HTR0129A00000	<b>Spanner</b>	All models with tension nut on the nose (Including Swallow/Swift Steel)	10,50
BYB0371A00000	<b>Rubber bar end plugs natural</b>	Bar tape Cambium	8,50
BYB0372A00000	<b>Rubber bar end plugs black</b>	Bar tape Cambium	8,50







# OVERVIEW

# Selle Royal

## ALL JOURNEYS RANGE

---



ON ATHLETIC  
€ 89,90



ON MODERATE  
€ 89,90



ON RELAXED  
€ 89,90

---

**NEW**



ON OPEN ATHLETIC  
€ 89,90

**NEW**



ON OPEN MODERATE  
€ 89,90

**NEW**



ON OPEN RELAXED  
€ 89,90

---



RESPIRO ATHLETIC  
€ 79,90



RESPIRO MODERATE  
€ 79,90



RESPIRO RELAXED  
€ 79,90

---



LOOKIN ATHLETIC  
€ 69,90



LOOKIN MODERATE  
€ 69,90



LOOKIN RELAXED  
€ 69,90

---



LOOKIN EVO ATHLETIC  
€ 74,90



LOOKIN EVO MODERATE  
€ 74,90



LOOKIN EVO RELAXED  
€ 74,90

---

## ADVENTURE TIME RANGE



VAIA ATHLETIC  
€ 69,90



VAIA MODERATE  
€ 69,90



VAIA RELAXED  
€ 69,90



EXPLORA ATHLETIC  
€ 69,90



EXPLORA MODERATE  
€ 69,90



EXPLORA RELAXED  
€ 69,90

## URBAN LIFE RANGE



ELLIPSE ATHLETIC  
€ 54,90



ELLIPSE MODERATE  
€ 54,90



ELLIPSE RELAXED  
€ 54,90



FREEWAY FIT ATHLETIC  
€ 44,90



FREEWAY FIT MODERATE  
€ 44,90



FREEWAY FIT RELAXED  
€ 44,90



FLOAT ATHLETIC  
€ 44,90



FLOAT MODERATE  
€ 44,90



FLOAT RELAXED  
€ 44,90

# Selle Royal

## URBAN LIFE RANGE



AVENUE ATHLETIC  
€ 39,90



AVENUE MODERATE  
€ 39,90



AVENUE RELAXED  
€ 39,90



VIVO ATHLETIC  
€ 29,90



DRIFTER STRENGTEX  
RELAXED  
€ 54,90



DRIFTER PLUS RELAXED  
€ 54,90



ONDINA RELAXED  
€ 34,90



HOLLAND RELAXED  
€ 29,90



WITCH RELAXED  
€ 19,90

## KIDS SADDLES RANGE



FROGGY / BOY & GIRL  
€ 19,90



CANDY / GIRL  
€ 19,90



BEN / BOY  
€ 19,90



HELLO / BOY & GIRL  
€ 19,90

## SADDLES BAGS



MEDIUM 1,2L  
€ 19,90



LARGE 2,0L  
€ 24,90



EXTRA LARGE 7,0L  
€ 59,90

## SEAT COVERS



ROYALGEL™ SMALL  
€ 19,90



ROYALGEL™ LARGE  
€ 19,90



SLOW FIT FOAM SMALL  
€ 19,90



SLOW FIT FOAM LARGE  
€ 19,90

## SCIENTIA RANGE



SCIENTIA A1 ATHLETIC  
SMALL  
€ 89,90



SCIENTIA A2 ATHLETIC  
MEDIUM  
€ 89,90



SCIENTIA A3 ATHLETIC  
LARGE  
€ 89,90



SCIENTIA M1 MODERATE  
SMALL  
€ 89,90



SCIENTIA M2 MODERATE  
MEDIUM  
€ 89,90



SCIENTIA M3 MODERATE  
LARGE  
€ 89,90



SCIENTIA R1 RELAXED  
SMALL  
€ 89,90



SCIENTIA R2 RELAXED  
MEDIUM  
€ 89,90



SCIENTIA R3 RELAXED  
LARGE  
€ 89,90

## REMED RANGE



REMED SPORT ATHLETIC  
€ 26,90



REMED TREKKING MODERATE  
€ 26,90



REMED CITY RELAXED  
€ 26,90

ROAD SADDLES



VENTO ARGO 00  
ADAPTIVE  
140mm/150mm  
€ 399



VENTO ARGO R1  
ADAPTIVE  
140mm/150mm  
€ 299



VENTO ARGO R3  
ADAPTIVE  
140mm/150mm  
€ 259



VENTO ARGO 00  
140mm/150mm  
€ 299



VENTO ARGO R1  
140mm/150mm  
€ 199



VENTO ARGO R3  
140mm/150mm  
€ 149



VENTO ARGO R5  
140mm/150mm  
€ 109



TEMPO ARGO R1  
150mm/160mm  
€ 199



TEMPO ARGO R3  
150mm/160mm  
€ 149



TEMPO ARGO R5  
150mm/160mm  
€ 109



VENTO ANTARES 00  
140mm/150mm  
€ 299



VENTO ANTARES R1  
140mm/150mm  
€ 199



VENTO ANTARES R3  
140mm/150mm  
€ 149



VENTO ANTARES R5  
140mm/150mm  
€ 109



TEMPO ALIANTE R1  
145mm/155mm  
€ 199



TEMPO ALIANTE R3  
145mm/155mm  
€ 149



TEMPO ALIANTE R5  
145mm/155mm  
€ 109



ARIONE 00  
€ 299



ARIONE R1  
126mm/140mm  
€ 199



ARIONE R3  
126mm/140mm  
€ 149



ARIONE CLASSIC  
€ 129



ARIONE R1 OPEN  
132mm/142mm  
€ 199



ARIONE R3 OPEN (Black)  
132mm/142mm  
€ 149



ARIONE R3 OPEN (White)  
132mm/142mm  
€ 149

**TRIATHLON SADDLES**



TRANSIRO AERIS LD R1  
€ 199



TRANSIRO AERIS LD R3  
€ 149



TRANSIRO AERIS LD R5  
€ 109



TRANSIRO AERIS SD R1  
€ 199



TRANSIRO AERIS SD R3  
€ 149



TRANSIRO AERIS SD R5  
€ 109

**OFF-ROAD SADDLES**



VENTO ARGO X1  
140mm/150mm  
€ 199



VENTO ARGO X3  
140mm/150mm  
€ 149



VENTO ARGO X5  
140mm/150mm  
€ 109



TERRA ARGO X1  
140mm/150mm/160mm  
€ 199



TERRA ARGO X3  
140mm/150mm/160mm  
€ 149



TERRA ARGO X5  
140mm/150mm/160mm  
€ 109



TERRA ALPACA X5  
+ CARRIAGE KIT  
€ 109



GRAVITA ALPACA X5  
+ CARRIAGE KIT  
€ 99



TERRA AIDON X1  
145mm/160mm  
€ 179



TERRA AIDON X3  
145mm/160mm  
€ 139



TERRA AIDON X5  
145mm/160mm  
€ 89



ROAD SHOES



VENTO INFINITO KNIT  
CARBON 2  
Black/Black  
€ 380



VENTO INFINITO KNIT  
CARBON 2  
Coral/Black  
€ 380



VENTO INFINITO  
CARBON 2  
Black/Black  
€ 380



VENTO INFINITO  
CARBON 2  
White/Black  
€ 380



VENTO INFINITO  
CARBON 2  
Grey/Coral\*\*  
€ 380



NEW

VENTO POWERSTRAP  
AEROWEAVE CARBON  
White/White  
€ 350



NEW

VENTO POWERSTRAP  
AEROWEAVE CARBON  
Coral/Orange  
€ 350



TEMPO DECOS CARBON  
Aubergine  
€ 290



TEMPO DECOS CARBON  
Black/Black  
€ 290



TEMPO DECOS CARBON  
Iridescent Blue  
€ 290



TEMPO DECOS CARBON  
White/White  
Available also in WIDE version  
€ 290



VENTO OMNA  
Black/Black  
€ 165



VENTO OMNA  
White/Black  
Available also in WIDE version  
€ 165



VENTO OMNA  
Red/Black  
€ 165



VENTO OMNA  
Metallic Gun Metal/Black  
€ 165



VENTO OMNA  
Cherry/Black  
€ 165



TEMPO OVERCURVE R4  
White/Black  
€ 219



TEMPO OVERCURVE R4  
Navy/Black  
€ 219



TEMPO OVERCURVE R4  
Black/Black  
Available also in WIDE version  
€ 219



TEMPO OVERCURVE R4  
Copper/Black Iridescent  
€ 219



TEMPO OVERCURVE R4  
Beetle/Black Iridescent  
€ 219



TEMPO OVERCURVE R5  
Black/Black\*\*  
€ 119



TEMPO OVERCURVE R5  
White/Black\*\*  
€ 119



TEMPO OVERCURVE R5  
Black/Pink Fluo\*\*  
€ 119



TEMPO OVERCURVE R5  
Black/Yellow Fluo\*\*  
€ 119



TEMPO OVERCURVE R5  
Metallic Gun Metal/Black\*\*  
€ 119



TEMPO POWERSTRAP R5  
Black/Black  
€ 139



TEMPO POWERSTRAP R5  
White/Black  
€ 139



TEMPO POWERSTRAP R5  
Reflective Grey/Black  
€ 149

**ROAD SHOES**



TEMPO ARTICA R5 GTX  
Black/Black  
€ 259



TEMPO ARTICA R5 GTX  
White/Grey  
€ 259

**TRIATHLON SHOES**



TRANSIRO HYDRA  
AEROWEAVE CARBON  
White/Silver  
€ 290



TRANSIRO HYDRA  
AEROWEAVE CARBON  
White/Red-Blue  
€ 290



TRANSIRO HYDRA  
White/Black  
€ 149



TRANSIRO HYDRA  
White/Metallic Red  
€ 149



TRANSIRO HYDRA  
White/Metallic Blue  
€ 149

**OFF-ROAD SHOES**



VENTO FEROX CARBON  
Black/Black  
€ 299



VENTO FEROX CARBON  
Lilac/White  
€ 299



**NEW**

VENTO PROXY  
Black/Black  
€ 229



**NEW**

VENTO PROXY  
Coral/Purple  
€ 229



**NEW**

VENTO PROXY  
White/White  
€ 229



TERRA ATLAS  
Grey/Black  
€ 159



TERRA ATLAS  
Black/Black  
€ 159



TERRA ATLAS  
Army  
€ 159



TERRA ATLAS  
Pink Grape  
€ 159



TERRA ATLAS  
Black/Splash Purple  
Limited edition  
€ 159



TERRA ATLAS  
Green/Splash Pink  
Limited edition  
€ 159



VENTO OVERCURVE X3  
Black/Black\*\*  
€ 229



VENTO OVERCURVE X3  
White/Black\*\*  
€ 229

(\*\*) Until sold out | Solange der Vorrat reicht

**OFF-ROAD SHOES**



TERRA POWERSTRAP X4  
Mud/Caramel  
€ 159



TERRA POWERSTRAP X4  
Black/Black  
€ 159



TERRA CLIMA X2  
Black/Black  
€ 250



TERRA ERGOLACE X2  
Teal Blue/Black  
€ 129



TERRA ERGOLACE X2  
Olive/Caramel  
€ 129



TERRA ERGOLACE X2  
Black/Black  
Available also in FLAT version  
€ 129



GRAVITA TENSOR  
Black/Black  
Available also in FLAT version  
€ 179



GRAVITA VERSOR  
Grey/Mud  
Available also in FLAT version  
€ 139

**GORE-TEX SHOES**



TERRA ERGOLACE X2 GTX  
Ice Grey/Black  
€ 189



TERRA ERGOLACE X2 GTX  
Anthracite/Black  
€ 189



TERRA ARTICA X5 GTX  
Black/Black  
€ 259



TERRA ARTICA X5 GTX  
Purple/Black  
€ 259

**VENTO MICROTEX TACKY BARTAPES (Thickness 2mm)**



Black € 40,90    White € 40,90    Red € 40,90    Orange Fluo € 40,90    Pink Fluo € 40,90    Yellow Fluo € 40,90    Lilla Fluo € 40,90    Celeste € 40,90

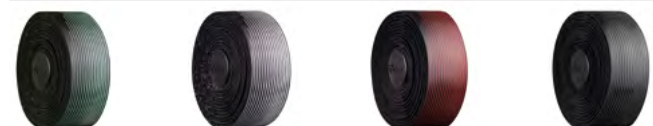

Black/Celeste € 43,90    Black/White € 43,90    Black/Red € 43,90    Black/Grey € 43,90

**VENTO SOLOCUSH TACKY BARTAPES (Thickness 2,7mm)**



Black € 43,90    White € 43,90    Blue € 43,90    Green € 43,90    Red € 43,90    Pink € 43,90    Yellow € 43,90    Orange Fluo € 43,90



Pink Fluo € 43,90    Yellow Fluo € 43,90    Lilla Fluo € 43,90    Celeste € 43,90    Mint Green € 43,90    Light Grey € 43,90    Dark Grey € 43,90

**TEMPO MICROTEX CLASSIC BARTAPES (Thickness 2mm)**



Black € 23,90    White € 23,90    Blue € 23,90    Green € 23,90    Red € 23,90    Pink € 23,90    Yellow € 23,90    Orange € 23,90



Honey € 23,90    Silver € 23,90    Celeste € 23,90

**TEMPO MICROTEX BOND CUSH BARTAPES (Thickness 3mm)**



Black € 30,90    White € 30,90    Honey € 30,90

**TEMPO MICROTEX BOND CUSH SOFT BARTAPE (Thickness 3mm)**



Black € 30,90    Red € 30,90

**TEMPO MICROTEX BOND CUSH TACKY BARTAPE - Les Classiques (Thickness 3mm)**



Le Classiques - Limited Edition € 43,90

**TERRA MICROTEX BOND CUSH TACKY BARTAPES (Thickness 3mm)**



Black € 43,90    White € 43,90    Red € 43,90    Dark Blue € 43,90    Green/Blue € 43,90    Brown € 43,90    Light Grey € 43,90

(\*\*) Until sold out | Solange der Vorrat reicht



## MALLET PEDALS



MALLET DH 11  
Black/Gold  
€ 350



MALLET DH RACE  
Black/Black  
€ 180



MALLET DH RACE  
Red/Red  
€ 180



MALLET E 11  
Black/Gold  
€ 350



MALLET E  
Black/Black  
€ 180



MALLET E  
Electric Blue/Blue  
€ 180



MALLET E LS  
Blue/Black\*\*  
€ 180



MALLET E LS  
Silver/Black\*\*  
€ 180



MALLET E LS  
Lime Green/Black/Black\*\*  
Splatter edition  
€ 180



MALLET E LS  
Blue/Black/Black\*\*  
Splatter edition  
€ 180



MALLET TRAIL  
Black/Black  
€ 180



MALLET TRAIL  
Champagne/Black  
€ 180



MALLET TRAIL  
Purple/Black  
€ 180



MALLET 3  
Raw/Black/Blue  
€ 150



MALLET 3  
Raw/Red/Red\*\*  
€ 150



MALLET 2  
Raw/Green/Black\*\*  
€ 100



MALLET 2  
Raw/Silver/Black  
€ 100



## CANDY PEDALS

---



CANDY 11  
Gold/Gold  
€ 500

---



CANDY 7  
Black/Electric Blue/Black  
€ 180



CANDY 7  
Black/Black  
€ 180



CANDY 7  
Red/Red  
€ 180

---



CANDY 3  
Black/Black  
€ 150



CANDY 3  
Dark Red/Red\*\*  
€ 150



CANDY 3  
Slate Blue/Blue  
€ 150

---



CANDY 2  
Dark Grey/Black  
€ 100



CANDY 2  
Red/Black  
€ 100

---



CANDY 1  
Black/Black  
€ 60



CANDY 1  
Light Blue/Blue  
€ 60



CANDY 1  
Red/Red  
€ 60



CANDY 1  
Pink/Pink  
€ 60

---



## EGGBEATER PEDALS



EGGBEATER 11  
Gold/Gold  
€ 500



EGGBEATER 3  
Light Blue/Electric Blue  
€ 150



EGGBEATER 3  
Red/Red  
€ 150



EGGBEATER 3  
Black/Black  
€ 150



EGGBEATER 2  
Black/Black  
€ 100



EGGBEATER 2  
Black/Green  
€ 100



EGGBEATER 1  
Silver/Red  
€ 60



EGGBEATER 1  
Silver/Black  
€ 60

## DOUBLE SHOT PEDALS



DOUBLE SHOT 3  
Black/Black  
€ 150



DOUBLE SHOT 3  
Red/Black/Black  
€ 150



DOUBLE SHOT 2  
Black/Silver/Blue  
€ 100



DOUBLE SHOT 2  
Orange/Black/Orange  
€ 100



DOUBLE SHOT 2  
Blue/Black/Black  
€ 100



DOUBLE SHOT 1  
Black/Black  
€ 60



DOUBLE SHOT 1  
Blue/Black  
€ 60



DOUBLE SHOT 1  
Red/Black  
€ 60



## STAMP PEDALS



STAMP 11 - Small/Large  
Black/Gold  
€ 300



STAMP 7 - Small/Large  
Black  
€ 180



STAMP 7 - Small/Large  
Red  
€ 180



STAMP 7 - Small/Large  
Electric Blue  
€ 180



STAMP 7 - Small/Large  
High Polish Silver  
€ 190



STAMP 7 - Small/Large  
Lime Green\*\*  
Splatter edition  
€ 180



STAMP 7 - Small/Large  
Red\*\*  
Splatter edition  
€ 180



STAMP 7 - Small  
Blue\*\*  
Splatter edition  
€ 180



STAMP 3 - Small/Large  
Black Magnesium  
€ 140



STAMP 3 - Small/Large  
Silver Magnesium  
€ 140



STAMP 2 - Small/Large  
Raw Silver  
€ 100



STAMP 2 - Small/Large  
Black  
€ 100



STAMP 1 - Small/Large  
Black  
€ 50



STAMP 1 - Small/Large  
Red  
€ 50



STAMP 1 - Small/Large  
Blue  
€ 50



STAMP 1 - Small/Large  
Orange  
€ 50



NEW

STAMP 1 GEN 2  
Small/Large  
Black  
€ 60



NEW

STAMP 1 GEN 2  
Small/Large  
Red  
€ 60



NEW

STAMP 1 GEN 2  
Small/Large  
Orange  
€ 60



NEW

STAMP 1 GEN 2  
Small/Large  
Navy Blue  
€ 60



NEW

STAMP 1 GEN 2  
Small/Large  
Purple  
€ 60

(\*\*) Until sold out | Solange der Vorrat reicht





## MALLET TRAIL SHOES



NEW

MALLET TRAIL BOA  
Black/Gold  
€ 220



NEW

MALLET TRAIL LACE  
Black/Black  
€ 170



NEW

MALLET TRAIL LACE  
White/Purple  
€ 170



NEW

MALLET TRAIL LACE  
Blue/Blue  
€ 170

## STAMP TRAIL SHOES



NEW

STAMP TRAIL BOA  
Black/Gold  
€ 200



NEW

STAMP TRAIL LACE  
Black/Black  
€ 150



NEW

STAMP TRAIL LACE  
White/Purple  
€ 150



NEW

STAMP TRAIL LACE  
Blue/Blue  
€ 150

## MALLET SHOES



MALLET BOA  
Black/Gold  
€ 200



MALLET SPEEDLACE  
Black/White  
€ 170



MALLET LACE  
Black/Red  
€ 150



MALLET LACE  
Red/Black\*\*  
PumpForPeace edition  
€ 160



MALLET LACE  
Grey/Blue\*\*  
Splatter edition  
€ 150



MALLET LACE  
Petrol/Lime\*\*  
Splatter edition  
€ 150

## MALLET E SHOES



MALLET E BOA  
Black/Gold\*\*  
€ 200



MALLET E SPEEDLACE  
Green/Blue\*\*  
€ 170



MALLET E LACE  
Black/Blue\*\*  
€ 150

(\*\*) Until sold out | Solange der Vorrat reicht



## STAMP SHOES



STAMP BOA  
Black/Gold  
€ 180



STAMP SPEEDLACE  
Black/White  
€ 150



STAMP SPEEDLACE  
Purple/Teal Blue  
€ 150



STAMP SPEEDLACE  
Green/Orange\*\*  
€ 150



STAMP SPEEDLACE  
Grey/Red\*\*\*  
€ 150



STAMP LACE  
Black/Silver  
€ 130



STAMP LACE  
White/White  
€ 130



STAMP LACE  
Navy/Silver  
€ 130



STAMP LACE  
Red/Black\*\*  
PumpForPeace edition  
€ 140



STAMP LACE  
Grey/Blue\*\*  
Splatter edition  
€ 130



STAMP LACE  
Petrol/Lime\*\*  
Splatter edition  
€ 130

## STAMP STREET SHOES



STAMP STREET LACE  
Black/Gold  
€ 130



STAMP STREET LACE  
White/Gold  
€ 130

## CANDY GRAVEL/XC SHOES



CANDY GRAVEL / XC LACE  
Black/Black  
€ 160



CANDY GRAVEL / XC LACE  
White/Grey  
€ 160

(\*\*) Until sold out | Solange der Vorrat reicht



## ALLOY WHEELS



SYNTHESIS XCT ALLOY  
Alloy Single Wheel  
€ 240 front / € 360 rear

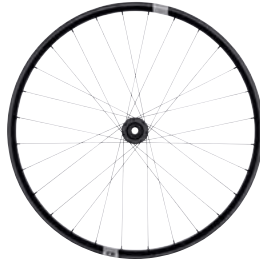

SYNTHESIS E ALLOY  
Alloy Single Wheel  
€ 240 front / € 360 rear



SYNTHESIS E-BIKE ALLOY  
Alloy Single Wheel  
€ 300 front / € 400 rear



NEW

SYNTHESIS GRAVEL  
Alloy Single Wheel  
€ 240 front / € 360 rear



COBALT 2  
Alloy Wheelsets  
€ 600



IODINE 2  
Alloy Wheelsets  
€ 600



ZINC 3  
Alloy Wheelsets  
€ 800

## CARBON WHEELS



SYNTHESIS XCT 11  
Carbon Wheelsets  
€ 2.400



SYNTHESIS E 11  
Carbon Wheelsets  
€ 2.400



NEW

SYNTHESIS GRAVEL  
Carbon Single Wheel  
€ 600 front / € 900 rear

## GRIPS



COBALT  
Silver  
€ 30



COBALT  
Gold  
€ 30



COBALT  
Red  
€ 30



IODINE  
Black  
€ 30



---

## DROPPER SEATPOST

---



HIGHLINE 11  
100/125/150/170 mm  
**€ 400**

---



HIGHLINE 7  
100/125/150/170/200 mm  
**€ 300**

---



HIGHLINE 3  
80/100/125/150/170/200 mm  
**€ 200**

---



HIGHLINE XC/GRAVEL  
60/80/100/125 mm  
**€ 250**

---

**CAMBIUM SADDLES**



C13 145mm/158mm  
Black  
€ 200



C13 Carved 145mm/158mm  
Black  
€ 200



C15  
Black  
€ 130



C15 Carved  
Black  
€ 130



C17  
Black  
€ 130



C17 Colored Top  
Brown  
€ 130



C17 Colored Top  
Mud Green  
€ 130



C17 Colored Top  
Bronze Orange  
€ 130



C17 Colored Top  
Octane  
€ 130



C17 Carved  
Black  
€ 130



C17 Carved Colored Top  
Brown  
€ 130



C17 Carved Colored Top  
Mud Green  
€ 130



C17 Carved Colored Top  
Bronze Orange  
€ 130



C17 Carved Colored Top  
Octane  
€ 130



C17 Special Organic Cotton  
Black/Natural Rubber  
€ 160



C17 Special Organic Cotton  
Black/Black Rubber  
with Copper Rivets  
€ 160



C17 Special Organic Cotton  
Natural/Natural Rubber  
€ 160



C19  
Black  
€ 130



C19 Carved  
Black  
€ 130



C67  
Black  
€ 130

(\*\*) Until sold out | Solange der Vorrat reicht

**LEATHER SADDLES**



SWIFT  
Black  
€ 190



SWIFT  
Honey  
€ 190



SWIFT  
Antique Brown  
€ 190



SWALLOW  
Black  
€ 190



SWALLOW  
Honey  
€ 190



SWALLOW  
Antique Brown  
€ 190



B17 Narrow  
Black  
€ 150



B17 Narrow  
Honey  
€ 150



B17 Narrow  
Antique Brown  
€ 150



B17  
Black  
€ 150



B17  
Honey  
€ 150



B17  
Antique Brown  
€ 150



B17 Short  
Black  
€ 150



B17 Short  
Honey  
€ 150



B17 Short  
Antique Brown  
€ 150



B17 Carved  
Black  
€ 150



B17 Carved  
Honey  
€ 150



B17 Carved  
Antique Brown  
€ 150



B17 Softened  
Dark Tan  
€ 150

(\*\*) Until sold out | Solange der Vorrat reicht

**LEATHER SADDLES**



B17 Special  
Black  
€ 190



B17 Special  
Honey  
€ 190



B17 Special  
Antique Brown  
€ 190



B17 Special Titanium  
Black  
€ 260



FLYER  
Black  
€ 160



FLYER  
Honey  
€ 160



FLYER  
Antique Brown  
€ 160



FLYER Short  
Black  
€ 160



FLYER Short  
Honey  
€ 160

**NEW**



FLYER Short  
Antique Brown  
€ 160

**NEW**



FLYER Carved  
Black  
€ 160



FLYER Carved  
Honey  
€ 160



FLYER Carved  
Antique Brown  
€ 160



FLYER Softened  
Dark Tan  
€ 160



B33  
Black  
€ 230



B33  
Honey  
€ 230

**LEATHER SADDLES**



B66  
Black  
€ 180



B66  
Honey  
€ 180



B66  
Antique Brown  
€ 180



B66 Short  
Black  
€ 180

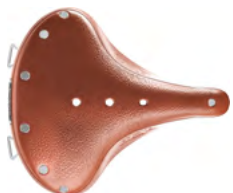

B66 Short  
Honey  
€ 180



B66 Short  
Antique Brown  
€ 180



B67  
Black  
€ 160



B67  
Honey  
€ 160



B67  
Antique Brown  
€ 160



B67 Short  
Black  
€ 160



B67 Short  
Honey  
€ 160



B67 Short  
Antique Brown  
€ 160



**NEW**

B68  
Black  
€ 160



**NEW**

B68  
Honey  
€ 160



**NEW**

B68  
Antique Brown  
€ 160



**NEW**

B72  
Black  
€ 180



**NEW**

B72  
Antique Brown  
€ 180



## ERGONOMIC RUBBER GRIPS



130/130 mm  
Black  
€ 60



130/100 mm  
Black  
€ 60



100/100 mm  
Black  
€ 60

## CAMBIUM RUBBER GRIPS



130/130 mm  
Black  
€ 45



130/100 mm  
Black  
€ 45



130/130 mm  
Natural  
€ 45



130/100 mm  
Natural  
€ 45

## CAMBIUM RUBBER BAR TAPE



Textured 3mm  
Comfort Padding  
Black  
€ 45



Textured 3mm  
Comfort Padding  
Natural/Rubber  
€ 45



Textured 3mm  
Comfort Padding  
Brown  
€ 45



Textured 3mm  
Comfort Padding  
Mud Green  
€ 45



Textured 3mm  
Comfort Padding  
Bronze Orange  
€ 45

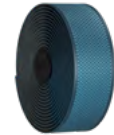

Textured 3mm  
Comfort Padding  
Octane  
€ 45

## SLENDER LEATHER GRIPS



130/130 mm  
Black  
€ 90



130/100 mm  
Black  
€ 90



100/100 mm  
Black  
€ 90



130/130 mm  
Honey  
€ 90



130/100 mm  
Honey  
€ 90



100/100 mm  
Honey  
€ 90



130/130 mm  
Antique Brown  
€ 90



130/130 mm  
Dark Tan  
€ 90

## LEATHER BAR TAPE



Perforated  
Leather Tape  
Black  
€ 70



Perforated  
Leather Tape  
Honey  
€ 70



Perforated  
Leather Tape  
Antique Brown  
€ 70

## MICROFIBER BAR TAPE



3mm  
Comfort Padding  
Black  
€ 35



3mm  
Comfort Padding  
Honey  
€ 35



3mm  
Comfort Padding  
Antique Brown  
€ 35

**BIKE BAGS**



CHALLENGE SADDLE BAG  
Black  
€ 115



CHALLENGE SADDLE BAG  
Honey  
€ 115



CHALLENGE SADDLE BAG  
Antique Brown  
€ 115



CHALLENGE SADDLE BAG  
Dark Tan  
€ 115

**SCAPE BAGS - HANDLEBAR BAGS**



HANDLEBAR CASE  
8L - Mud Green  
€ 140



FEED POUCH  
1,2L - Mud Green  
€ 50



FEED POUCH  
1,2L - Black  
€ 50



HANDLEBAR POUCH  
3L - Mud Green  
€ 70



HANDLEBAR POUCH  
3L - Black  
€ 70



HANDLEBAR COMPACT  
BAG 10L - Mud Green  
€ 120



HANDLEBAR ROLL  
10/12L - Mud Green  
€ 140



HANDLEBAR ROLL  
10/12L - Black  
€ 140

**SCAPE BAGS - SADDLE BAGS**



SEAT BAG  
8/10L - Mud Green  
€ 140



SEAT BAG  
8/10L - Black  
€ 140



SADDLE POCKET BAG  
0,7L - Mud Green  
€ 50



SADDLE POCKET BAG  
0,7L - Black  
€ 50



SADDLE ROLL BAG  
1L - Mud Green  
€ 50

**SCAPE BAGS - PANNIERS**



SMALL PANNIER  
10/13L - Mud Green  
€ 120



SMALL PANNIER  
10/13L - Black  
€ 120



LARGE PANNIER  
18/22L - Mud Green  
€ 125



LARGE PANNIER  
18/22L - Black  
€ 125

## SCAPE BAGS - FRAME BAGS



FULL FRAME  
5,5L - Mud Green  
**€ 120**



FULL FRAME  
5,5L - Black  
**€ 120**



FRAME BAG  
3L - Mud Green  
**€ 95**



FRAME BAG  
3L - Black  
**€ 95**



FRAME BAG LARGE  
3,5L - Mud Green  
**€ 100**



FRAME BAG LARGE  
3,5L - Black  
**€ 100**



LONG TOP TUBE BAG  
1,5L - Mud Green  
**€ 65**



LONG TOP TUBE BAG  
1,5L - Black  
**€ 65**



TOP TUBE BAG  
0,9L - Mud Green  
**€ 55**  
**€ 65 with bolts**



TOP TUBE BAG  
0,9L - Black  
**€ 55**  
**€ 65 with bolts**

## PICKWICK BACKPACK 12L



PICKWICK  
COTTON CANVAS  
12L - Total Black  
**€ 220**



PICKWICK  
COTTON CANVAS  
12L - Grey/Honey  
**€ 220**



PICKWICK  
COTTON CANVAS  
12L - Sage Green/Honey  
**€ 220**



PICKWICK  
COTTON CANVAS  
12L - Dark Blue/Black  
**€ 220**

**NEW**



PICKWICK  
COTTON CANVAS  
12L - Goose Beak/Maroon  
**€ 220**

**NEW**



**NEW**

PICKWICK  
COTTON CANVAS  
12L - Forest  
**€ 220**

**PICKWICK BACKPACK 26L**



PICKWICK  
COTTON CANVAS  
26L - Total Black  
€ 250



PICKWICK  
COTTON CANVAS  
26L - Grey/Honey  
€ 250



PICKWICK  
COTTON CANVAS  
26L - Forest  
€ 250



PICKWICK  
COTTON CANVAS  
26L - Dark Blue/Black  
€ 250



PICKWICK  
COTTON CANVAS  
26L - Goose Beak/Maroon  
€ 250

**NEW**



**NEW**

PICKWICK  
COTTON CANVAS  
26L - Sage Green/Honey  
€ 250

**BASKET**



HOXTON BASKET  
25L - Aluminium  
€ 190

**PANNIERS**



BRICKLANE  
ROLL-UP PANNIERS  
15L - Grey/Honey  
€ 200



BRICKLANE  
ROLL-UP PANNIERS  
15L - Sage Green/Honey  
€ 200



BRICKLANE  
ROLL-UP PANNIERS  
15L - Goosebeak/Maroon  
€ 200

# A4 SALES AGENTS

## AUSTRIA / SWITZERLAND

### SALES AREA MANAGER

**Luca Miorandi**

M +39 3351279549

luca.miorandi@selleroyalgroup.com

## AUSTRIA

### SALES AGENTS

**Jens Rosenhäger**

M +43 6764712122

rosenhaeger@gmx.at

**COPYRIGHT.** All contents of this catalog, including texts, documents, logos, images, graphics, videos, their own arrangement and adaptation within the site, are protected by the Copyright © laws of Selle Royal Group S.p.A. and other intellectual property rights. The reproduction, alteration, modification, publication and use, even partial, of this content for any purpose, whether commercial or not, in any format and support, are not permitted without the express written permission of Selle Royal Group S.p.A. All rights reserved.

**BRAND NAMES.** All trademarks and logos in the catalog are the exclusive property of their respective owners. Any use and/or reproduction of the same for any purpose or means is expressly and strictly prohibited and will be prosecuted.

**LIABILITY LIMITS.** The contents and information in the catalog are provided "as is" and periodically updated and checked. Consequently, they may not be complete, accurate or updated at any time, or may contain errors. Selle Royal Group S.p.A. disclaims any liability and any warranty regarding the completeness, updating, errors and omissions of the information and content contained in the catalog.

**COPYRIGHT.** Sämtliche Inhalte in diesem Katalog, einschließlich Texte, Dokumente, Logos, Bilder, Grafiken, Videos, sowie deren Anordnung und deren Adaption innerhalb der Seite, unterliegen dem Urheberrecht der Selle Royal Group S.p.A. und anderen Gesetzen zum Schutz geistigen Eigentums. Eine Vervielfältigung, Abänderung, Bearbeitung, Veröffentlichung, Verbreitung des Inhaltes, ganz oder teilweise, für kommerzielle oder anderweitige Verwendung ist ausdrücklich nur gestattet wenn eine schriftliche Erlaubnis der Selle Royal Group S.p.A. vorliegt. Alle Rechte vorbehalten.

**MARKENZEICHEN.** Sämtliche gezeigte Markenzeichen und Logos innerhalb dieses Katalogs sind ausschließliches Eigentum ihrer jeweiligen Besitzer. Jegliche Benutzung und/oder eine Reproduktion dieser ist ausdrücklich und strengstens verboten und wird strafrechtlich verfolgt.

**HAFTUNGSHINWEIS.** Die Inhalte und Informationen, die in diesem Katalog zur Verfügung gestellt werden, gelten als gegeben und werden regelmäßig überprüft und überarbeitet. Folglich können diese unvollständig, bereits überarbeitet oder fehlerhaft sein. Selle Royal Group S.p.A. übernimmt keine Haftung oder Gewähr für Vollständigkeit, Aktualität, Fehler und Versäumnisse auf die bereitgestellten Inhalte und Informationen in diesem Katalog.



#### **HEADQUARTER / ZENTRALE**

Selle Royal Group S.p.A.  
Via Vittorio Emanuele 119  
36050 Pozzoleone (VI) Italy

#### **CONTACTS / KONTAKTE**

T +39 0444 461100  
T +39 0444 461102  
info@a4selection.com  
www.a4selection.com

#### **COMPLAINTS AND RETURNS / REKLAMATIONEN UND RÜCKGABEN**

info@a4selection.com  
(to receive the return authorization and all the related instructions)  
(um die Rückgabegenehmigung und alle damit verbundenen Anweisungen zu erhalten)

#### **CRANKBROTHERS ASSISTANCE SERVICE / SERVICE CRANKBROTHERS ÖSTERREICH**

Pippo Wheels S.r.l.  
Via S. Venier 15  
36100 Vicenza (VI) Italy  
T +39 0444 532052  
crankbrothers@pippowheels.com

#### **GUARANTEE / GARANTIE**

The products in this catalog are covered by a **2 YEARS** guarantee from the purchase date  
Die im Katalog anwesende Produkte sind eine **2 JAHRE** Garantie ab Kaufdatum abgeichert

**Selle Royal**

SELLEROYAL.COM

**fi'zi:k**

FIZIK.COM



crankbrothers

CRANKBROTHERS.COM

**Continental** 

CONTINENTAL-TIRES.COM

**BROOKS**

18 ENGLAND 66

BROOKSENGLAND.COM



**A4SELECTION.COM**

